

Agilent E5052B Signal Source Analyzer

Service Guide

First Edition



Agilent Technologies

Manufacturing No. E5052-90200

May 2007

Notices

The information contained in this document is subject to change without notice.

This document contains proprietary information that is protected by copyright. All rights are reserved. No part of this document may be photocopied, reproduced, or translated to another language without the prior written consent of Agilent Technologies.

Microsoft®, MS-DOS®, Windows®, Visual C++®, Visual Basic®, VBA® and Excel® are registered

UNIX is a registered trademark in U.S. and other countries, licensed exclusively through X/Open Company Limited.

Portions ©Copyright 1996, Microsoft Corporation. All rights reserved.

© Copyright 2007 Agilent Technologies

Manual Printing History

The manual's printing date and part number indicate its current edition. The printing date changes when a new edition is printed. (Minor corrections and updates that are incorporated at reprint do not cause the date to change.) The manual part number changes when extensive technical changes are incorporated.

May 2007 First Edition

Safety Summary

The following general safety precautions must be observed during all phases of operation, service, and repair of this instrument. Failure to comply with these precautions or with specific WARNINGS elsewhere in this manual may impair the protection provided by the equipment. Such noncompliance would also violate safety standards of design, manufacture, and intended use of the instrument. Agilent Technologies assumes no liability for the customer's failure to comply with these precautions.

-
- | | |
|-------------|-------------------------------------------------------------------------------------------------------------------------------------|
| NOTE | The E5052B complies with INSTALLATION CATEGORY II as well as POLLUTION DEGREE 2 in IEC61010-1. The E5052B is an INDOOR USE product. |
|-------------|-------------------------------------------------------------------------------------------------------------------------------------|
-
- | | |
|-------------|---------------------------------------------------------------------------------------|
| NOTE | The LEDs in the E5052B are Class 1 in accordance with IEC60825-1, CLASS 1 LED PRODUCT |
|-------------|---------------------------------------------------------------------------------------|
-
- | | |
|-------------|--------------------------------------------------------------------------------------|
| NOTE | This equipment is MEASUREMENT CATEGORY I (CAT I). Do not use for CAT II, III, or IV. |
|-------------|--------------------------------------------------------------------------------------|
-
- | | |
|-------------|-------------------------------------------------------------------------------------------------------------------------------------------------------------------------------------------------------------------------------------------------------------------------------------------------------------------------------------------------------------------------|
| NOTE | This equipment is tested with stand-alone condition or with the combination with the accessories supplied by Agilent Technologies against the requirement of the standards described in the Declaration of Conformity. If it is used as a system component, compliance of related regulations and safety requirements are to be confirmed by the builder of the system. |
|-------------|-------------------------------------------------------------------------------------------------------------------------------------------------------------------------------------------------------------------------------------------------------------------------------------------------------------------------------------------------------------------------|
-
- Ground the Instrument

To avoid electric shock, the instrument chassis and cabinet must be grounded with the supplied power cable's grounding prong.
 - DO NOT Operate in an Explosive Atmosphere

Do not operate the instrument in the presence of inflammable gasses or fumes. Operation of any electrical instrument in such an environment clearly constitutes a safety hazard.
 - Keep Away from Live Circuits

Operators must not remove instrument covers. Component replacement and internal adjustments must be made by qualified maintenance personnel. Do not replace components with the power cable connected. Under certain conditions, dangerous voltage levels may remain even after the power cable has been disconnected. To avoid injuries, always disconnect the power and discharge circuits before touching them.
 - DO NOT Service or Adjust the Instrument Alone

Do not attempt internal service or adjustment unless another person, capable of rendering first aid and resuscitation, is present.
 - DO NOT Substitute Parts or Modify the Instrument

To avoid the danger of introducing additional hazards, do not install substitute parts or perform unauthorized modifications to the instrument. Return the instrument to an Agilent Technologies Sales and Service Office for service and repair to ensure that

safety features are maintained in operational condition.

- Dangerous Procedure Warnings

Warnings, such as the example below, precede potentially dangerous procedures throughout this manual. Instructions contained in the warnings must be followed.

WARNING

Dangerous voltage levels, capable of causing death, are present in this instrument. Use extreme caution when handling, testing, and adjusting this instrument.

- Do not connect the measuring terminals to mains.

Safety Symbols

General definitions of safety symbols used on the instrument or in manuals are listed below.



Instruction Manual symbol: the product is marked with this symbol when it is necessary for the user to refer to the instrument manual.



Alternating current.



Direct current.



On (Supply).



Off (Supply).



In position of push-button switch.



Out position of push-button switch.



Frame (or chassis) terminal. A connection to the frame (chassis) of the equipment which normally include all exposed metal structure.



Stand-by.

WARNING

This warning sign denotes a hazard. It calls attention to a procedure, practice, condition or the like, which, if not correctly performed or adhered to, could result in injury or death to personnel.

CAUTION

This Caution sign denotes a hazard. It calls attention to a procedure, practice, condition or the like, which, if not correctly performed or adhered to, could result in damage to or destruction of part or all of the product.

NOTE

Note denotes important information. It calls attention to a procedure, practice, condition or the like, which is essential to highlight.

Certification

Agilent Technologies certifies that this product met its published specifications at the time of shipment from the factory. Agilent Technologies further certifies that its calibration measurements are traceable to the United States National Institute of Standards and Technology, to the extent allowed by the Institution's calibration facility, or to the calibration facilities of other International Standards Organization members.

Documentation Warranty

The material contained in this document is provided "as is," and is subject to being changed, without notice, in future editions. Further, to the maximum extent permitted by applicable law, Agilent disclaims all warranties, either express or implied with regard to this manual and any information contained herein, including but not limited to the implied warranties of merchantability and fitness for a particular purpose. Agilent shall not be liable for errors or for incidental or consequential damages in connection with the furnishing, use, or performance of this document or any information contained herein. Should Agilent and the user have a separate written agreement with warranty terms covering the material in this document that conflict with these terms, the warranty terms in the separate agreement will control.

Exclusive Remedies

The remedies provided herein are buyer's sole and exclusive remedies. Agilent Technologies shall not be liable for any direct, indirect, special, incidental, or consequential damages, whether based on contract, tort, or any other legal theory.

Assistance

Product maintenance agreements and other customer assistance agreements are available for Agilent Technologies products.

For any assistance, contact your nearest Agilent Technologies Sales and Service Office. Addresses are provided at the back of this manual.

Typeface Conventions

Sample (bold)

Boldface type is used when a term is defined or emphasised.

Sample (Italic)

Italic type is used for emphasis.

Sample key / [Sample] key

Indicates a hardkey (key on the front panel or external keyboard) labeled “Sample.” “key” may be omitted.

Sample menu/button/box

Indicates a menu/button/box on the screen labeled “Sample” which can be selected/executed by clicking. “menu,” “button,” or “box” may be omitted.

Sample block/toolbar

Indicates a block (group of hardkeys) or a toolbar (setup toolbar) labeled “Sample.”

Sample 1 - Sample 2 - Sample 3

Indicates a sequential operation of **Sample 1**, **Sample 2**, and **Sample 3** (menu, button, or box). “-” may be omitted.

1. General Information

Precautions	16
Software Installed	16
Organization of Service Guide	17
Instrument Covered by This Manual	19
Required Equipment	20

2. Performance Tests

Introduction	24
Test Equipment Required	24
Individual Test Description	25
1. RF IN Port VSWR Test	25
2. Frequency Measurement Test	26
3. Power Measurement Accuracy Test	27
4. Phase Noise Accuracy Test	28
5. SSB Phase Noise Sensitivity Test	29
6. SA Relative Level Accuracy Test	30
7. DC Power Voltage Test	31
8. DC Power Current Measurement Test	32
E5052B Performance Test Calculation Sheet	33
Introduction	33
Phase Noise Accuracy Test	33
SA Relative Level Accuracy Test	35
E5052B Performance Test Record	38
RF IN Port VSWR Test	38
Frequency Measurement Test	38
Power Measurement Accuracy Test	40
Phase Noise Accuracy Test	42
SSB Phase Noise Sensitivity Test (for Standard)	43
SSB Phase Noise Sensitivity Test (for Option 011)	43
SA Relative Level Accuracy Test	43
DC Power Voltage Test	45
DC Current Measurement Test	46

3. Adjustment

Safety Considerations	48
Warm-up for Adjustment	48
Required Equipment	48
Required Adjustment after Replacing Assembly	49
Writing ID	49
DC Control Voltage Adjustment	50
DC Power Voltage Adjustment	50
DC Power Current Adjustment	50
Reference Frequency Adjustment	51
Pre-LO Sampler PLL BW Adjustment	51
Receiver DC offset Adjustment	51
PM Offset Adjustment	52
PM Linearity Adjustment	53

Contents

PM Temp Adjustment	53
PM Flatness Adjustment	54
Receiver RF Flatness Adjustment	54
Receiver IF Gain/Flatness Adjustment	55
Receiver RF Flatness Dir Adjustment	55
Receiver IF Gain/Flatness Dir Adjustment	56
LO Sampler PLL BW Adjustment	56
Phase Noise BW Adjustment	57
FLL BW Adjustment	57
4. Troubleshooting	
Introduction	60
How to exit from the E5052B Measurement View	61
To Troubleshoot the Instrument	62
Primary Trouble Isolation	62
No Display troubleshooting	64
Booting Process Troubleshooting	66
Troubleshooting Using Service Function	70
Power On Test	70
Contents of the power on test results	71
Power On Test Failure Troubleshooting	73
Function Specific Troubleshooting	75
To Check the Device Driver	76
To Check the Front Panel	78
To Check the Touch Panel	79
To Check the LCD	79
To Check the External Keyboard	80
To Check the Mouse	80
To Check the Video output	80
To Check the External Trigger Input	80
To Check the GPIB	81
To Check the 24-bit I/O port	81
To Check the Oven Ch1	81
To Check the Oven Ch2	82
To Check the USB (USBTMC) Interface Card	82
Performance test failure troubleshooting	84
Recommended adjustment for performance test failure	84
Adjustment failure troubleshooting	85
Performance test failure troubleshooting	85
To configure the A20 Digital Motherboard and BIOS	87
To Identify the Motherboard Installed	87
Testing DRAM on the Motherboard	87
To Confirm or Set the BIOS Options	88
5. Replaceable Parts	
Ordering Information	92
Direct Mail Order System	92
Exchange Assemblies	92

Replaceable Parts List	93
Power Cables and Plug Configurations	93
Top View (Major Assemblies)	94
Top View (Cables)	96
Top View (Miscellaneous Parts)	98
Top View (Under Power Supply)	100
Top View (Motherboard and Other Parts)	102
Bottom View	104
Front View (Analog Boards)	105
Front View (Cables)	106
Front View (Miscellaneous)	107
Front Panel	108
Rear View	110
Cover Assembly	111
Left Side View	112
Right Side View	113
Removable Hard Disk Drive Assembly	114
PCI DSP Card and GPIB Card Assembly	115
USB Card Assembly	116
PCA Digital Board Assembly	117
Oven Ch1 Assembly	118
Oven Ch2 Assembly	119
DC Block Unit Assembly	120
Analog Mother Board Assembly	121
Freq/Power Detector Module Attachment Assembly	122
DC Source Board Attachment Assembly	123
Local Synthesize Module Assembly	124
Phase Detector Board Assembly	125
Chassis Assembly	127
Front Cover Assembly	129
Front Assembly (LCD)	130
Front Assembly (Standby Switch and PCA Prove Power)	131
Front Assembly (Front Keyboard)	132
Front Assembly (Inverter)	133
Label on Front Face	134
Label on Rear Face	135
Other Parts	136
6. Replacement Procedure	
Replacing an Assembly	138
Required Tools	139
Outer Cover Removal	140
Tools Required	140
Procedure	140
Front Panel Removal	142
Tools required	142
Procedure	142
A27 Removable Hard Disk Assembly Removal	144
Tools Required	144

Contents

Removal Procedure	144
Removable Hard Disk Drive Replacement	146
Tools Required	146
Save Backup Files to the PC	146
Removal procedure	146
Replacement Procedure	147
Restore Backup Files onto the New Removable Hard Disk Drive	148
Adjustment for the New Removable Hard Disk Drive	148
Calibration of the Touch Screen	148
Power Supply Assembly Replacement	150
Tools Required	150
Removal Procedure	150
Replacement Procedure	151
A26 Digital Bridge Board Replacement	152
Tools Required	152
Removal Procedure	152
Replacement Procedure	153
A25 24 bit I/O Board Replacement	154
Tools Required	154
Removal Procedure	154
Replacement Procedure	155
A21 PCI DSP / A24 GPIB Card Replacement	156
Tools Required	156
Removal Procedure	156
Replacement Procedure	157
A32 USB (USBTMC) Interface Card Replacement	158
Tools Required	158
Removal Procedure	158
Replacement Procedure	159
Oven CH1 Assembly Replacement	160
Tools Required	160
Removal Procedure	160
Replacement Procedure	161
Oven CH2 Assembly Replacement	162
Tools Required	162
Removal Procedure	162
Replacement Procedure	163
A57 DC Block Assembly Replacement	164
Tools Required	164
Removal Procedure	164
Replacement Procedure	165
Fan Replacement	166
Tools Required	166
Removal Procedure	166
Replacement Procedure	167
A22 Power Distribution Board Replacement	168
Tools Required	168
Removal Procedure	168
Replacement Procedure	169

A20 Digital Motherboard Replacement	170
Tools Required	170
Removal Procedure	170
Replacement Procedure	171
A1 Freq / Power Detector Module Replacement	172
Tools Required	172
Removal Procedure	172
Replacement Procedure	173
A2 DC Source Board Replacement	174
Tools Required	174
Removal Procedure	174
Replacement Procedure	175
A3 ADC/DSP Board Replacement	176
Tools Required	176
Removal Procedure	176
Replacement Procedure	177
A4/A5 Local Synthesize Module Replacement	178
Tools Required	178
Removal Procedure	178
Replacement Procedure	179
A6 Phase Detector Board Replacement	180
Tools Required	180
Removal Procedure	180
Replacement Procedure	181
A50 Analog Motherboard Replacement	182
Tools Required	182
Removal Procedure	182
Replacement Procedure	183
Front Panel Cover Removal	184
Tools Required	184
Removal Procedure	184
Control Touch Panel Replacement	185
Tools Required	185
Removal Procedure	185
Replacement Procedure	185
A52 Inverter Assembly Replacement	186
Tools Required	186
Removal Procedure	186
Replacement Procedure	187
A51 LCD Replacement	188
Tools Required	188
Removal Procedure	188
Replacement Procedure	189
A22 Front Keyboard Replacement	190
Tools Required	190
Removal Procedure	190
Replacement Procedure	191
Front USB PCA Board Replacement	192
Tools Required	192

Contents

Removal Procedure	192
Replacement Procedure	193
Probe Power and Power Switch Board Replacement	194
Tools Required	194
Removal Procedure	194
Replacement Procedure	195
Front BNC Connector Replacement	196
Tools Required	196
Removal Procedure	196
Replacement Procedure	197
7. Post-Repair Procedures	
Post-Repair Procedures	200
A. Manual Changes	
Manual Changes	206
B. System Recovery	
System Recovery	208
Types of system recoveries	208
Notes on executing the factory recovery function	208
Procedure to execute the factory recovery	209
Procedure to create the user backup image	212
Procedure to execute the user recovery function	218
Initial Registration of E5052B	229
Calibration of the Touch Screen	231
C. Firmware Update	
Firmware Update	234
Required Equipment	234
How to make E5052B Firmware Installation Device	234
How to update the E5052B Firmware	234
D. Power Requirement	
Power Supply and Blown Fuses	240
Verification of the power supply	240
Verification and connection of power cable	240
Blown fuses	242
Starting the E5052B	243
Turning the Power ON and OFF	243
Disconnection from supply source	244
E. Messages	
Error Messages	247
A	247
D	248
E	249

F 249
I 250
L 251
M 251
N 251
O 251
P 251
R 252
S 252
T 253
U 254

1 General Information

The Service Guide is a guide to servicing the E5052B Signal Source Analyzer. The guide contains information requisite to do performance tests, adjustments, troubleshooting, and repairs.

Precautions

This section describes cautions that must be observed in operating the E5052B.

Software Installed

The Windows operating system installed in this machine is customized for more effective operation, and has different functions that are not part of the Windows operating system for ordinary PCs (personal computers).

Therefore, do not attempt to use the system in ways other than those described in this manual or to install Windows-based software (including anti-virus software) for ordinary PCs as doing so may cause malfunctions.

Also note the followings.

- Do not update the Windows operating system installed in this machine to the Windows operating system for ordinary PCs. Doing so will cause malfunctions.
- Do not attempt to update VBA (Visual Basic for Applications) software installed in this machine to its equivalent developed for ordinary PCs. Doing so will cause malfunctions.
- Do not allow any computer virus to infect the system. This machine has no virus check function nor anti-virus software installed.

Agilent Technologies will not be held liable for any failure or damage arising from negligence regarding these prohibitions and warnings.

NOTE

If the pre-installed software is damaged somehow, resulting in errant behavior by the machine, perform a system recovery. For further details of system recovery, refer to Appendix B.

Organization of Service Guide

Tabs are used to divide the major chapter and appendix of this manual. The contents of each chapter and appendix in this manual is as follows;

Chapter 1 , “General Information,”

The Service Guide is a guide to servicing the E5052B Signal Source Analyzer. The guide contains information requisite to do performance tests, adjustments, troubleshooting, and repairs.

Chapter 2 , “Performance Tests,”

This chapter provides information on how to verify the E5052B performance.

Chapter 3 , “Adjustment,”

This chapter provides the adjustment information for the E5052B to ensure that it is within its specifications. The adjustment must be performed Agilent’s qualified service personnel. If you need the adjustment for your E5052B, it should be sent to the nearest Agilent Technologies service office.

Chapter 4 , “Troubleshooting,”

This chapter provides the procedure to isolate a faulty assembly in the E5052B.

Chapter 5 , “Replaceable Parts,”

This chapter contains information for ordering replacement parts for the E5052B.

Chapter 6 , “Replacement Procedure,”

This chapter provides procedure for removing and replacing the major assemblies in the E5052B.

Chapter 7 , “Post-Repair Procedures,”

This chapter lists the procedures required to verify the E5052B operation after an assembly is replaced with a new one.

Appendix A , “Manual Changes,”

This appendix contains the information required to adapt this manual to versions or configurations of the E5052B manufactured earlier than the current printing date of this manual. The information in this manual applies directly to the E5052B units with the serial number that is printed on the title page of this manual.

Appendix B , “System Recovery,”

This appendix describes how to recover the operating system (Windows XP) when the operating system has been damaged.

Appendix C , “Firmware Update,”

This appendix describes how to update the E5052B firmware. When you want to update the E5052B firmware, refer to this appendix.

General Information
Organization of Service Guide

Appendix D , “Power Requirement,”

Appendix E, “Messages,”

The E5052B can display error messages as well as messages that indicate the internal operating status of the equipment. This appendix explains what these messages mean. They are listed in alphabetical order.

Instrument Covered by This Manual

Agilent Technologies uses a two-part, ten-character serial number label (See Figure 1-1) attached to the instrument's rear panel. The first five characters are the serial prefix and the last five digits are the suffix.

Figure 1-1

Serial Number Label Example

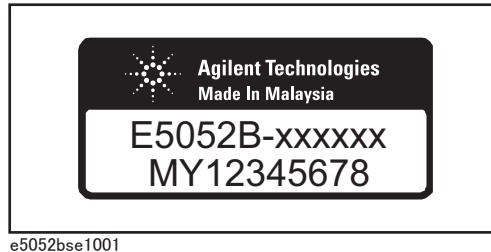

e5052bse1001

An instrument manufactured after the printing date of this manual may have serial number prefix that is not listed on the title page. This unlisted serial number prefix indicates the instrument is different from those described in this manual. The manual for this new instrument may be accompanied by a yellow Manual Changes supplement or have a different manual part number. This sheet contains “change information” that explains how to adapt the manual to the newer instrument.

In addition to change information, the supplement may contain information for correcting errors (Errata) in the manual. To keep this manual as current and accurate as possible, Agilent Technologies recommends that you periodically request the latest Manual Changes supplement. The supplement for this manual is identified by this manual's printing data and is available from Agilent Technologies. If the serial prefix or number of an instrument is lower than that on the title page of this manual, see Appendix A, Manual Changes. For information concerning, a serial number prefix that is not listed on the title page or in the Manual change supplement, contact the nearest Agilent Technologies office.

Required Equipment

Table 1-1 lists the recommended equipment for performing maintenance on the E5052B.

Table 1-1 Recommended Test Equipment

Equipment	Critical specifications	Recommended Model	Qty.	Use*1
Signal Generator	Frequency: 10 MHz to 7 GHz Low SSB Phase Noise	Agilent E8257D with Opt. UNX, UNT, 1EA without Opt. UNW, 1EH	1	P,A
Network Analyzer	Frequency: 10 M to 3 GHz	Agilent E5070B/71B	1	P
Power Meter	No Substitute	Agilent E4419B	1	P,A
Power Sensor	No Substitute	Agilent E9304A Opt. H18	1	P,A
Power Amplifier	Gain: 35 dB, Freq range: 10M to 3 GHz	R&K A3000-2H-R	1	P,A
Power Amplifier	Gain: 35 dB, Freq range: 3 G to 7 GHz	Agilent 83020A	1	P,A
Multimeter	No Substitute	Agilent 3458A	1	P,A
Function Generator	No Substitute	Agilent 33250A	1	A
Calibration Kit	Frequency: 10 M to 7 GHz	Agilent 85032F	1	P
Frequency Counter	Frequency: 10 MHz	Agilent 53181A Opt.010	1	T
Step Attenuator	Attenuator range: 0 dB to 50 dB Step: 10dB, Freq range: 10 M to 7 GHz	Agilent 8496H	1	P,A
Blocking Capacitor	No Substitute	Agilent 11742A	1	P,A
Power divider	No substitute	Agilent 11636A	1	P
Fixed attenuator (3 dB)	50 Ω , N(m)-N(f), 3 dB	Agilent 8491A Opt.003	2	P,A
Power Splitter	N(f) 50 Ω in, N(f) 50 Ω out	Agilent 11667A	1	P,A
Band Pass Filter	70 MHz, Band width 10 kHz	FILTRONETICS FN-2063M	1	P
Low Pass Filter	70 MHz	Mini-Circuits SLP-70	1	A
Resistor	141 Ω , 1 W	Agilent p/n 0698-3615 (47ohm), 3 ea	1	P, A
Feed Thru Termination	50 Ω , 1W	Agilent 04192-61002	1	A
50 Ω Termination	50 Ω (N)	Agilent 909C Opt. 012	1	A

Table 1-1 Recommended Test Equipment

Equipment	Critical specifications	Recommended Model	Qty.	Use ^{*1}
50 Ω Termination	50 Ω (BNC)	Agilent 11593A	1	A
Handler I/O Test Kit	No substitute	Agilent p/n E5070-65001	1	T
Cable	BNC(m)-BNC(m) Cable, 61 cm	Agilent p/n 8120-1839	2	P,A,T
	BNC(m)-BNC(m) Cable, 122 cm	Agilent p/n 8120-1840	2	P,A
	Coaxial cable with Type-N (m) connectors, 61 cm (24 in)	Agilent N6314A (p/n 8120-8862)	4	P,A
Adapter	N(f)-SMA(m) Adapter	Agilent p/n 1250-1562	2	P,A
	N(f)-N(f) Adapter	Agilent p/n 1250-0777	1	P,A
	N(m)-N(m) Adapter	Agilent p/n 1250-1475	1	P,A
	N(f)-BNC(m) Adapter	Agilent p/n 1250-1477	1	P,A
	N(m)-BNC(f) Adapter	Agilent p/n 1250-0780	1	P,A
	BNC Tee Adapter	Agilent p/n 1250-0781	1	A
	Dual Banana-BNC(f)	Agilent p/n 1251-2277	1	P,A
Torque Wrench	Size: 3/4 inch Torque: 136 N-cm	Agilent p/n 8710-1766	1	P,A
Personal Computer with GPIB board	Windows XP, VEE 7.52 or later		1	P,A

*1.P: Performance Tests, A: Adjustment, T: Troubleshooting

General Information
Required Equipment

Table 1-2 Alternative Test Equipment

Equipment	Critical specifications	Model	Qty.	Use *1
Signal Generator	Frequency: 10 MHz to 7 GHz Low SSB Phase Noise	Agilent E8267D with Opt. UNX, UNT, 1EA without Opt. UNW, 1EH	1	P,A
Multimeter	No Substitute	Agilent 34401A Agilent 34410A Agilent 34411A	1	P,A
Network Analyzer	Frequency: 10 M to 3 GHz	Agilent 8753ES	1	P
Power Meter	No Substitute	Agilent E4419A	1	P,A
Power Sensor	No Substitute	Agilent E9304A Opt. H19	1	P,A
Step Attenuator	Attenuator range: 0 dB to 50 dB Step: 10dB, Freq range: 10 M to 7 GHz	Agilent 8495H	1	P,A

*1. P: Performance Tests, A: Adjustment, T: Troubleshooting

2 Performance Tests

This chapter provides information on how to verify the E5052B performance.

Introduction

This chapter provides the performance tests procedures for Agilent E5052B. The performance test names are listed in Table 2-1.

NOTE Allow the analyzer to warm up for at least 30 minutes before you execute any of the performance tests.

Perform all performance tests in an ambient temperature of 23 ± 5 °C

NOTE The performance tests should be performed periodically. The recommended test interval is 12 months.

The test interval depends on maintenance and the environmental conditions under which the instrument is used. You may find that the interval could be shortened or lengthened; however, such a decision should be based on substantial quantitative data.

Table 2-1 List of the E5052B performance tests

Para.	Title
1	RF Input Impedance Test
2	Frequency Measurement Test
3	Power Measurement Accuracy Test
4	Phase Noise Accuracy Test
5	SSB Phase Noise Sensitivity Test
6	SA Relative Level Accuracy Test
7	DC Power Voltage Test
8	DC Power Current Measurement Test

This test report is included the Test Accuracy Ratio(TAR) and the Measurement Uncertainty(MU), and the definitions are as follows;

MU: The reported expanded uncertainty of measurement is stated as the standard uncertainty of measurement multiplied by the coverage factor $k=2$, which for a normal distribution corresponds to a coverage probability of approximately 95%.

TAR: TAR is the ratio obtained by dividing the specification of calibrated item by the uncertainty of the standards and methods used. The ration is not described for the single-sided measurements.

Test Equipment Required

The required equipment for the performance test is listed in Table 1-1and Table 1-2. Use only calibrated equipment when doing the performance test.

Individual Test Description

1. RF IN Port VSWR Test

Description

This test checks the VSWR of the E5052B's RF IN port with a network analyzer. The VSWR is checked at 10 MHz to 3 GHz.

Test equipment

Network Analyzer	Agilent E5070B/5071B
Calibration Kit	Agilent 85032F
N(m)-N(m) cable, 61 cm	Agilent N6314A(p/n 8120-8862)

2. Frequency Measurement Test

Description

This test checks the frequency measurement accuracy of the E5052B. The frequency measurement is checked for each frequency band and each frequency resolution of the E5052B

Test equipment

Signal Generator	Agilent E8257D with Opt. UNX, UNT, 1EA without Opt. UNW, 1EH
RF Amplifier (AMP 1)	R&K A3000-2H-R
RF Amplifier (AMP 2)	Agilent 83020A
Power Meter	Agilent E4419B
Power Sensor	Agilent E9304A Opt. H18 or Agilent E9304A Opt. H19
Step Attenuator	Agilent 8496H
Power Splitter	Agilent 11667A
Blocking Capacitor	Agilent 11742A
N(f)-SMA(m) adapter, 2 ea.	Agilent p/n 1250-1562
3 dB Fixed Attenuator, 2 ea.	Agilent 8491A Opt.003
N(m)-N(m) cable 61cm, 3 ea.	Agilent N6314A (p/n 8120-8862)
N(m)-N(m) Adapter	Agilent p/n 1250-1475
BNC cable, 122cm	Agilent p/n 8120-1840

3. Power Measurement Accuracy Test

Description

This test checks the RF power measurement accuracy of the E5052B. The measurement power level for this test is set at -20 dBm to 20 dBm in 10 dB step.

Test equipment

Signal Generator	Agilent E8257D with Opt. UNX, UNT, 1EA without Opt. UNW, 1EH
RF Amplifier (AMP 1)	R&K A3000-2H-R
RF Amplifier (AMP 2)	Agilent 83020A
Power Meter	Agilent E4419B
Power Sensor	Agilent E9304A Opt. H18 or Agilent E9304A Opt. H19
Step Attenuator	Agilent 8496H
Power Splitter	Agilent 11667A
Blocking Capacitor	Agilent 11742A
N(f)-SMA(m) adapter, 2 ea.	Agilent p/n 1250-1562
3 dB Fixed Attenuator, 2 ea.	Agilent 8491A Opt.003
N(m)-N(m) cable 61cm, 3 ea.	Agilent N6314A (p/n 8120-8862)
N(m)-N(m) Adapter	Agilent p/n 1250-1475
BNC cable, 122cm	Agilent p/n 8120-1840

4. Phase Noise Accuracy Test

Description

This test checks the phase noise accuracy of the E5052B. The mixed signals generated by two signal generators are used, and the carrier frequencies for this test are 10 MHz and 1 GHz.

Test Equipment

Signal Generator 1	Agilent E8257D with Opt. UNX, UNT, 1EA without Opt. UNW, 1EH
Signal Generator 2 (or Sweeper)	Agilent E5070B/71B (use of the source)
Power Meter	Agilent E4419B
Power Sensor	Agilent E9304A Opt. H18 or Agilent E9304A Opt. H19
Step Attenuator	Agilent 8496H
Power Splitter	Agilent 11667A
N(m)-N(m) Adapter	Agilent p/n 1250-1475
Power Divider	Agilent 11636A
N(m)-N(m) cable 61cm, 3 ea.	Agilent N6314A (p/n 8120-8862)
BNC cable, 122 cm, 2 ea.	Agilent p/n 8120-1840

5. SSB Phase Noise Sensitivity Test

Description

This test checks the SSB phase noise sensitivity of the E5052B. The carrier frequency for this test is 70 MHz.

Test equipment

Signal Generator	Agilent E8257D with Opt. UNX, UNT, 1EA without Opt. UNW, 1EH
Band Pass Filter	70 MHz, Band width 10 kHz, FILTRONETICS FN-2063M
N(m)-N(m) cable 61cm, 2 ea.	Agilent N6314A (p/n 8120-8862)
N(f)-BNC(m) Adapter, 2 ea.	Agilent p/n 1250-1477

6. SA Relative Level Accuracy Test

Description

This test checks the relative level accuracy for the spectrum monitor of the E5052B. The mixed signals generated by two signal generators are used, and the carrier frequencies for this test are 10 MHz, 1 GHz and 3 GHz.

Test Equipment

Signal Generator 1	Agilent E8257D with Opt. UNX, UNT, 1EA without Opt. UNW, 1EH
Signal Generator 2 (or Sweeper)	Agilent E5070B/71B (use of the source)
Power Meter	Agilent E4419B
Power Sensor	Agilent E9304A Opt. H18 or Agilent E9304A Opt. H19
Step Attenuator	Agilent 8496H
Power Splitter	Agilent 11667A
N(m)-N(m) Adapter	Agilent p/n 1250-1475
Power Divider	Agilent 11636A
N(m)-N(m) cable 61cm, 3 ea.	Agilent N6314A (p/n 8120-8862)
BNC cable, 122 cm, 2 ea.	Agilent p/n 8120-1840

7. DC Power Voltage Test

Description

This test checks the accuracy of the DC Power output voltage.

Test Equipment

Multimeter	Agilent 3458A, Agilent 34401A, Agilent 34410A or Agilent 34411A
BNC cable, 61 cm	Agilent p/n 8120-1839
Dual Banana-BNC(f) adapter	Agilent p/n 1251-2277

8. DC Power Current Measurement Test

Description

This test checks the accuracy of the DC Power current measurement function. This test uses a 141 Ω resistor to define the DC Power current.

Test Equipment

Multimeter	Agilent 3458A, Agilent 34401A, Agilent 34410A or Agilent 34411A
Resistor	141 Ω , 1 W (Agilent p/n 0698-3615 (47 Ω), 3ea)
BNC cable, 61 cm, 2 ea.	Agilent p/n 8120-1839
Dual Banana-BNC(f) adapter	Agilent p/n 1251-2277

E5052B Performance Test Calculation Sheet

Introduction

This section contains calculation sheets for each performance test that requires additional calculations to determine the final test result.

Use the calculation sheet in this section as an aid for recording raw measurement data and calculating the performance test results.

Calculation sheet entries are provided only for performance tests in which calculations are required to obtain the test results.

Phase Noise Accuracy Test

Table 2-2 Sheet for Reference Frequency (10 MHz)

Offset Frequency [Hz]	E5052B reading [dBm]	Power Meter reading [dBm]		Cal value of Setp Att [dB]	Test Result [dB]	Test Result equation
		SG1	SG2	SATT	Result	
E5052B						Result = E5052B Reading - (SG1 - (SG2 - SATT))
-1 M						
-1 k						
-100						
100						
1 k						
1 M						

Performance Tests
E5052B Performance Test Calculation Sheet

Table 2-3 Sheet for Reference Frequency (1 GHz)

Offset Frequency [Hz]	E5052B reading [dBm]	Power Meter reading [dBm]		Cal value of Setp Att [dB]	Test Result [dB]	Test Result equation
		SG1	SG2	SATT	Result	
-100 M						Result = E5052B Reading - (SG1 - (SG2 - SATT))
-40 M						
-10 M						
-1 M						
-1 k						
-100						
100						
1 k						
1 M						
10 M						
40 M						
100 M						

SA Relative Level Accuracy Test

Table 2-4 Sheet for Low Frequency (100 MHz)

Frequency [Hz]		Power meter reading [dBm]		E5052B reading [dBm]		Cal value of Step Att [dB]	Test Result [dB]	Test result equation
SG1	SG2	PM1	PM2	SA1	SA2	SATT	Result	
100 M	92.5 M							$\text{Result} = (\text{SA2} - \text{SA1}) - (\text{PM2} - \text{PM1} - \text{SATT})$
	93.5 M							

2. Performance Test

Performance Tests
E5052B Performance Test Calculation Sheet

Table 2-5 Sheet for High Frequency (1GHz)

Frequency [Hz]		Power meter reading [dBm]		E5052B reading [dBm]		Cal value of Step Att [dB]	Test Result [dB]	Test result equation
SG1	SG2	PM1	PM2	SA1	SA2	SATT	Result	
1 G	992.5 M							$\text{Result} = (\text{SA2} - \text{SA1}) - (\text{PM2} - \text{PM1} - \text{SATT})$
	993.5 M							

Table 2-6 Sheet for High Frequency (3 GHz)

Frequency [Hz]		Power meter reading [dBm]		E5052B reading [dBm]		Cal value of Step Att [dB]	Test Result [dB]	Test result equation
SG1	SG2	PM1	PM2	SA1	SA2	SATT	Result	
3 G	2992.5 M							$\text{Result} = (\text{SA2} - \text{SA1}) - (\text{PM2} - \text{PM1} - \text{SATT})$
	2993.5 M							

2. Performance Test

E5052B Performance Test Record

Agilent Technologies E5052B Signal Source Analyzer

Serial Number:		Option:	
Temperature:	°C	Test Date:	
Humidity:	% R.H.	Tested by:	
F/W Revision:			

RF IN Port VSWR Test

@ Input Attenuator = 0 dB

Frequency range [Hz]	Test limit	Test result	Measurement uncertainty
10 M - 30 M	< 1.6		± 0.042
30 M - 2 G	< 1.2		± 0.016
2 G - 3 G	< 1.3		± 0.025

@ Input Attenuator = 5 dB

Frequency range [Hz]	Test limit	Test result	Measurement uncertainty
10 M - 30 M	< 1.6		± 0.041
30 M - 2 G	< 1.2		± 0.015
2 G - 3 G	< 1.3		± 0.028

Frequency Measurement Test

@ Frequency Band: 10 MHz - 1.5 GHz, Power Level: -15 dBm

Frequency [Hz]	Frequency Resolution [Hz]	Test Limit [Hz]	Test result [Hz]	Measurement uncertainty [Hz]	TAR
10 M	64 k	± 64 k		± 2.32 k	27.6
10 M	1 k	± 1 k		± 3.44	290.7
10 M	10	± 10		± 0.11	90.9

@ Frequency Band: 10 MHz - 1.5 GHz, Power Level: -20 dBm

Frequency [Hz]	Frequency Resolution [Hz]	Test Limit [Hz]	Test result [Hz]	Measurement uncertainty [Hz]	TAR
30 M	64 k	± 64 k		± 13.09 k	4.9
30 M	1 k	± 1 k		± 5.54	180.5
30 M	10	± 10		± 0.16	62.5
1.499 G	64 k	± 64 k		± 3.43 k	18.7
1.499 G	1 k	± 1 k		± 6.97	167.5
1.499 G	10	± 10		± 0.25	40.0

@ Frequency Band: 10 MHz - 1.5 GHz, Power Level: +20 dBm

Frequency [Hz]	Frequency Resolution [Hz]	Test Limit [Hz]	Test result [Hz]	Measurement uncertainty [Hz]	TAR
10 M	64 k	± 64 k		± 0.89 k	71.9
10 M	1 k	± 1 k		± 4.39	227.8
10 M	10	± 10		± 0.18	55.6
1.499 G	64 k	± 64 k		± 2.32 k	27.6
1.499 G	1 k	± 1 k		± 16.60	60.2
1.499 G	10	± 10		± 0.70	14.3

@ Frequency Band: 250 MHz - 7 GHz, Power Level: -20 dBm

Frequency [Hz]	Frequency Resolution [Hz]	Test Limit [Hz]	Test result [Hz]	Measurement uncertainty [Hz]	TAR
301 M	64 k	± 64 k		± 1.29 k	49.6
301 M	1 k	± 1 k		± 4.42	226.2
301 M	10	± 10		± 0.12	83.3
7 G	64 k	± 64 k		± 1.01 k	63.4
7 G	1 k	± 1 k		± 5.21	191.9
7 G	10	± 10		± 0.28	35.7

Performance Tests
E5052B Performance Test Record

@ Frequency Band: 250 MHz - 7 GHz, Power Level: +20 dBm

Frequency [Hz]	Frequency Resolution [Hz]	Test Limit [Hz]	Test result [Hz]	Measurement uncertainty [Hz]	TAR
301 M	64 k	± 64 k		± 0.94 k	68.1
301 M	1 k	± 1 k		± 1.91	523.6
301 M	10	± 10		± 0.26	38.5
7 G	64 k	± 64 k		± 4.41 k	14.5
7 G	1 k	± 1 k		± 18.41	54.3
7 G	10	± 10		± 0.42	23.8

Power Measurement Accuracy Test

@ -20 dBm

Frequency [Hz]	Test limit [dB]	Test result [dB]	Measurement uncertainty [dB]	TAR
30 M	± 1.0		± 0.200	5.00
1 G	± 1.0		± 0.200	5.00
2.0125 G	± 1.0		± 0.200	5.00
3.0125 G	± 1.0		± 0.200	5.00
4.0125 G	± 1.0		± 0.300	3.33
5.0125 G	± 1.0		± 0.310	3.23
6.0125 G	± 1.0		± 0.300	3.33
7 G	± 1.0		± 0.300	3.33

@ -10 dBm

Frequency [Hz]	Test limit [dB]	Test result [dB]	Measurement uncertainty [dB]	TAR
10 M	± 1.0		± 0.210	4.76
1 G	± 1.0		± 0.170	5.90
2.0125 G	± 1.0		± 0.190	5.30
3.0125 G	± 1.0		± 0.200	5.00
4.0125 G	± 1.0		± 0.290	3.40
5.0125 G	± 1.0		± 0.290	3.40

Frequency [Hz]	Test limit [dB]	Test result [dB]	Measurement uncertainty [dB]	TAR
6.0125 G	± 1.0		± 0.290	3.40
7 G	± 1.0		± 0.300	3.30

@ 0 dBm

Frequency [Hz]	Test limit [dB]	Test result [dB]	Measurement uncertainty [dB]	TAR
10 M	± 1.0		± 0.210	4.80
1 G	± 0.5		± 0.170	2.90
2.0125 G	± 0.5		± 0.170	2.90
3.0125 G	± 1.0		± 0.170	5.90
4.0125 G	± 1.0		± 0.270	3.70
5.0125 G	± 1.0		± 0.280	3.60
6.0125 G	± 1.0		± 0.280	3.60
7 G	± 1.0		± 0.280	3.60

@ +10 dBm

Frequency [Hz]	Test limit [dB]	Test result [dB]	Measurement uncertainty [dB]	TAR
10 M	± 1.0		± 0.200	5.00
1 G	± 0.5		± 0.170	2.90
2.0125 G	± 0.5		± 0.170	2.90
3.0125 G	± 1.0		± 0.180	5.60
4.0125 G	± 1.0		± 0.280	3.60
5.0125 G	± 1.0		± 0.280	3.60
6.0125 G	± 1.0		± 0.280	3.60
7 G	± 1.0		± 0.280	3.60

@ +20 dBm

Frequency [Hz]	Test limit [dB]	Test result [dB]	Measurement uncertainty [dB]	TAR
10 M	± 1.0		± 0.200	5.00

Performance Tests
E5052B Performance Test Record

Frequency [Hz]	Test limit [dB]	Test result [dB]	Measurement uncertainty [dB]	TAR
1 G	± 0.5		± 0.170	2.90
2.0125 G	± 0.5		± 0.160	3.10
3.0125 G	± 1.0		± 0.180	5.60
4.0125 G	± 1.0		± 0.290	3.40
5.0125 G	± 1.0		± 0.280	3.60
6.0125 G	± 1.0		± 0.280	3.60
7 G	± 1.0		± 0.280	3.60

Phase Noise Accuracy Test

@ Frequency : 1 GHz

Offset Frequency [Hz]	Test limit [dB]	Test result [dB]	Measurement uncertainty [dB]	TAR
- 100 M	± 3.0		± 0.23	13.0
- 40 M	± 2.0		± 0.24	8.3
- 10 M	± 2.0		± 0.24	8.3
- 1 M	± 2.0		± 0.24	8.3
- 1 k	± 2.0		± 0.24	8.3
- 100	± 3.0		± 0.29	10.3
100	± 3.0		± 0.28	10.7
1 k	± 2.0		± 0.24	8.3
1 M	± 2.0		± 0.25	8.0
10 M	± 2.0		± 0.23	8.7
40 M	± 2.0		± 0.24	8.3
100 M	± 3.0		± 0.23	13.0

@ Frequency : 10 MHz

Offset Frequency [Hz]	Test limit [dB]	Test result [dB]	Measurement uncertainty [dB]	TAR
- 1 M	± 2.0		± 0.25	8.0
- 1 k	± 2.0		± 0.26	7.7

Offset Frequency [Hz]	Test limit [dB]	Test result [dB]	Measurement uncertainty [dB]	TAR
- 100	± 3.0		± 0.25	12.0
100	± 3.0		± 0.25	12.0
1 k	± 2.0		± 0.25	8.0
1 M	± 2.0		± 0.22	9.1

SSB Phase Noise Sensitivity Test (for Standard)

CW Frequency: 70 MHz, Correlation = 1, Start frequency = 1 Hz

Offset Frequency [Hz]	Test limit [dBc/Hz]	Test result [dBc/Hz]	Measurement uncertainty [dBc/Hz]
1 M	< -168		± 3.13
3 M	< -169		± 2.83
7 M	< -170		± 2.56

SSB Phase Noise Sensitivity Test (for Option 011)

CW Frequency: 70 MHz, Start frequency = 10 Hz

Offset Frequency [Hz]	Test limit [dBc/Hz]	Test result [dBc/Hz]	Measurement uncertainty [dBc/Hz]
1 M	< -156		± 3.01
3 M	< -157		± 3.24
7 M	< -159		± 2.81

SA Relative Level Accuracy Test

CW Frequency: 100 MHz

Offset Frequency [Hz]	Test limit [dB]	Test result [dB]	Measurement uncertainty [dB]	TAR
-7.5 M	± 1.5		± 0.280	5.36
-6.5 M	± 1.5		± 0.290	5.17
-5.5 M	± 1.5		± 0.300	5.00
-4.5 M	± 1.5		± 0.310	4.84
-3.5 M	± 1.5		± 0.320	4.69

Performance Tests
E5052B Performance Test Record

Offset Frequency [Hz]	Test limit [dB]	Test result [dB]	Measurement uncertainty [dB]	TAR
-2.5 M	± 1.5		± 0.320	4.69
-1.5 M	± 1.5		± 0.320	4.69
-0.5 M	± 1.5		± 0.320	4.69
+0.5 M	± 1.5		± 0.300	5.00
+1.5 M	± 1.5		± 0.310	4.84
+2.5 M	± 1.5		± 0.320	4.69
+3.5 M	± 1.5		± 0.330	4.55
+4.5 M	± 1.5		± 0.330	4.55
+5.5 M	± 1.5		± 0.340	4.41
+6.5 M	± 1.5		± 0.320	4.69
+7.5 M	± 1.5		± 0.330	4.55

CW Frequency: 1 GHz

Offset Frequency [Hz]	Test limit [dB]	Test result [dB]	Measurement uncertainty [dB]	TAR
-7.5 M	± 1.5		± 0.300	5.00
-6.5 M	± 1.5		± 0.330	4.55
-5.5 M	± 1.5		± 0.300	5.00
-4.5 M	± 1.5		± 0.310	4.84
-3.5 M	± 1.5		± 0.320	4.69
-2.5 M	± 1.5		± 0.320	4.69
-1.5 M	± 1.5		± 0.320	4.69
-0.5 M	± 1.5		± 0.300	5.00
+0.5 M	± 1.5		± 0.310	4.84
+1.5 M	± 1.5		± 0.320	4.69
+2.5 M	± 1.5		± 0.330	4.55
+3.5 M	± 1.5		± 0.330	4.55
+4.5 M	± 1.5		± 0.340	4.41
+5.5 M	± 1.5		± 0.320	4.69
+6.5 M	± 1.5		± 0.330	4.55

Offset Frequency [Hz]	Test limit [dB]	Test result [dB]	Measurement uncertainty [dB]	TAR
+7.5 M	± 1.5		± 0.290	5.17

CW Frequency: 3 GHz

Offset Frequency [Hz]	Test limit [dB]	Test result [dB]	Measurement uncertainty [dB]	TAR
-7.5 M	± 1.5		± 0.310	4.84
-6.5 M	± 1.5		± 0.360	4.17
-5.5 M	± 1.5		± 0.310	4.84
-4.5 M	± 1.5		± 0.360	4.17
-3.5 M	± 1.5		± 0.370	4.05
-2.5 M	± 1.5		± 0.320	4.69
-1.5 M	± 1.5		± 0.330	4.55
-0.5 M	± 1.5		± 0.370	4.05
+0.5 M	± 1.5		± 0.320	4.69
+1.5 M	± 1.5		± 0.330	4.55
+2.5 M	± 1.5		± 0.340	4.41
+3.5 M	± 1.5		± 0.370	4.05
+4.5 M	± 1.5		± 0.340	4.41
+5.5 M	± 1.5		± 0.330	4.55
+6.5 M	± 1.5		± 0.380	3.95
+7.5 M	± 1.5		± 0.320	4.69

DC Power Voltage Test

DC POWER Voltage [V]	Test limit [mV]	Test result [mV]	Measurement uncertainty [mV]	TAR
0	± 2.0		± 0.140	14.29
1	± 4.0		± 0.200	20.00
2	± 6.0		± 0.180	33.33
5	± 12.0		± 0.250	48.00
10	± 22.0		± 0.370	59.46
12	± 26.0		± 0.440	59.09

Performance Tests
E5052B Performance Test Record

DC POWER Voltage [V]	Test limit [mV]	Test result [mV]	Measurement uncertainty [mV]	TAR
16	± 34.0		± 0.540	62.96

DC Current Measurement Test

DC Current [mA]	Test limit [µA]	Test result [µA]	Measurement uncertainty [µA]	TAR
1	± 162.0		± 4.147	39.06
2	± 164.0		± 5.500	29.82
5	± 170.0		± 4.688	36.26
10	± 180.0		± 31.620	5.69
20	± 200.0		± 7.657	26.12
50	± 260.0		± 17.210	15.11
80	± 320.0		± 79.038	4.05

3 Adjustment

This chapter provides the adjustment information for the E5052B to ensure that it is within its specifications. The adjustment must be performed Agilent's qualified service personnel. If you need the adjustment for your E5052B, it should be sent to the nearest Agilent Technologies service office.

Safety Considerations

This manual contains NOTES, CAUTIONs, and WARNINGs that must be followed to ensure the safety of the operator and to keep the instrument in a safe and serviceable condition. The adjustment must be performed by Agilent's qualified service personnel.

WARNING

Any interruption of the protective ground conductor (inside or outside the equipment) or disconnection of the protective ground terminal can make the instrument dangerous. Intentional interruption of the protective ground system for any reason is prohibited.

Warm-up for Adjustment

Warm-up the E5052B for at least 30 minute before performing any of the following Adjustment procedures to ensure proper results and correct instrument operation.

Required Equipment

Table 1-1 on page 20 lists the equipment required to perform the Adjustment procedures described in this chapter. Use only calibrated test equipment when adjusting the E5052B.

Required Adjustment after Replacing Assembly

After replacing the following assembly, the adjustment items described in Table 3-1 must be required. The adjustment must be performed by Agilent’s qualified service personnel. If you need the adjustment for your E5052B, it should be sent to the nearest Agilent Technologies service office.

Table 3-1 Required Adjustment Item after Replacing Assembly

Replaced Assembly	Adjustment Item																	
	Writing ID	DC Control Voltage Adjustment	DC Power Voltage Adjustment	DC Power Current Adjustment	Reference Frequency Adjustment	Pre-LO Sampler PLL BW Adjustment	Receiver DC offset Adjustment	PM Offset Adjustment	PM Linearity Adjustment	PM Temp Adjustment	PM Flatness Adjustment	Receiver RF Flatness Adjustment	Receiver IF Gain/Flatness Adjustment	Receiver RF Flatness Dir Adjustment	Receiver IF Gain/Flatness Dir Adjustment	LO Sampler PLL BW Adjustment	Phase Noise BW Adjustment	FLL BW Adjustment
A1 Freq/Power Det.					√	√	√	√	√	√	√	√	√	√	√	√	√	√
A2 DC Source		√	√	√														
A3 ADC/DSP					√	√	√					√	√	√	√	√	√	√
A4/A5 Local Synt					√	√	√					√	√	√	√	√	√	√
A6 Phase Det					√	√	√					√	√	√	√	√	√	√
HDD		√	√	√	√	√	√	√	√	√	√	√	√	√	√	√	√	√
A21 PCI DSP Card	√																	

Writing ID

This item writes the serial number and the option structure into the E5052B.

Required equipment for the writing ID

None

Adjustment

Required Adjustment after Replacing Assembly

DC Control Voltage Adjustment

The purpose of this procedure is to adjust the DC control voltage of the DC source of the A2 DC Source board.

Required equipment for DC control voltage adjustment

Description	Recommended Model
Multimeter	Agilent 3458A, Agilent 34401A, Agilent 34410A or Agilent 34411A
BNC(f)-Banana Adapter	Agilent p/n 1251-2277
BNC(m)-BNC(m) Cable, 61 cm	Agilent p/n 8120-1839

DC Power Voltage Adjustment

The purpose of this procedure is to adjust the DC power voltage of the A2 DC source board.

Required equipment for the DC power voltage adjustment

Description	Recommended Model
Multimeter	Agilent 3458A, Agilent 34401A, Agilent 34410A or Agilent 34411A
BNC(f)-Banana Adapter	Agilent p/n 1251-2277
BNC(m)-BNC(m) Cable, 61 cm	Agilent p/n 8120-1839

DC Power Current Adjustment

The purpose of this procedure is to adjust the DC power current measurement of the A1 freq/power detector module.

Required equipment for the DC power current adjustment

Description	Recommended Model
Multimeter	Agilent 3458A, Agilent 34401A, Agilent 34410A or Agilent 34411A
141 ohm Load	Agilent p/n 0698-3615 (47 Ω), 3ea
BNC(f)-Banana Adapter	Agilent p/n 1251-2277
BNC Tee Adapter	Agilent p/n 1250-0781
BNC(m)-BNC(m) Cable, 61 cm	Agilent p/n 8120-1839

Reference Frequency Adjustment

The purpose of this procedure is to adjust the reference frequency of the A4/A5 local synthesizer modules.

Required equipment for reference frequency adjustment

Description	Recommended Model
Signal Generator	Agilent E8257D with Opt. UNX, UNT, 1EA without Opt. UNW, 1EH
N(m)-N(m) Cable	Agilent N6314A (p/n 8120-8862)

Pre-LO Sampler PLL BW Adjustment

The purpose of this procedure is to pre-adjust the LO sampler PLL BW of the A4/A5 local synthesizer modules.

Required equipment for the Pre-LO sampler PLL BW adjustment

Description	Recommended Model
Signal Generator	Agilent E8257D with Opt. UNX, UNT, 1EA without Opt. UNW, 1EH
N(m)-N(m) Cable	Agilent N6314A (p/n 8120-8862)

Receiver DC offset Adjustment

The purpose of this procedure is to adjust the DC offset of the Receiver section (A6 Phase detector board and A3 ADC/DSP board).

Required equipment for the receiver DC offset adjustment

Description	Recommended Model
50 ohm (N) Termination	Agilent 909C Opt. 012
50 ohm (BNC) Termination	Agilent 11593A

PM Offset Adjustment

The purpose of this procedure is to adjust the PM offset of the A1 freq/power detector module.

Required equipment for the PM offset adjustment

Description	Recommended Model
Signal Generator	Agilent E8257D with Opt. UNX, UNT, 1EA without Opt. UNW, 1EH
Power Amplifier (35dB)	R & K A3000-2H-R
Step Attenuator	Agilent 8496H
Attenuator (3dB)	Agilent 8491A Opt. 003
Blocking Capacitor	Agilent 11742A
Low Pass Filter	Mini-Circuits SLP-70 (70MHz)
Power Splitter	Agilent 11667A
Power Sensor	Agilent E9304A Opt. H18 or Agilent E9304A Opt. H19
Power Meter	Agilent E4419A/B
N(m)-N(m) Cable	Agilent N6314A (p/n 8120-8862)
N(m)-N(m) Adapter	Agilent p/n 1250-1475
N(f)-SMA(m) Adapter	Agilent p/n 1250-1562

PM Linearity Adjustment

The purpose of this procedure is to adjust the PM linearity of the A1 freq/power detector module.

Required equipment for the PM linearity adjustment

Description	Recommended Model
Signal Generator	Agilent E8257D with Opt. UNX, UNT, 1EA without Opt. UNW, 1EH
Power Amplifier (35dB)	R & K A3000-2H-R
Step Attenuator	Agilent 8496H
Attenuator (3dB)	Agilent 8491A Opt. 003
Blocking Capacitor	Agilent 11742A
Low Pass Filter	Mini-Circuits SLP-70 (70MHz)
Power Splitter	Agilent 11667A
Power Sensor	Agilent E9304A Opt. H18 or Agilent E9304A Opt. H19
Power Meter	Agilent E4419A/B
N(m)-N(m) Cable	Agilent N6314A (p/n 8120-8862)
N(m)-N(m) Adapter	Agilent p/n 1250-1475
N(f)-SMA(m) Adapter	Agilent p/n 1250-1562

PM Temp Adjustment

The purpose of this procedure is to adjust the PM temp of the A1 freq/power detector module.

Required equipment for the PM temp adjustment

None

PM Flatness Adjustment

The purpose of this procedure is to adjust the PM flatness of the A1 freq/power detector module.

Required equipment for the PM flatness adjustment

Description	Recommended Model
Signal Generator	Agilent E8257D with Opt. UNX, UNT, 1EA without Opt. UNW, 1EH
Power Splitter	Agilent 11667A
Power Sensor	Agilent E9304A Opt. H18 or Agilent E9304A Opt. H19
Power Meter	Agilent E4419A/B
N(m)-N(m) Cable	Agilent N6314A (p/n 8120-8862)
N(m)-N(m) Adapter	Agilent p/n 1250-1475

Receiver RF Flatness Adjustment

The purpose of this procedure is to adjust the RF flatness of the A6 phase detector board.

Required equipment for the receiver RF flatness adjustment

Description	Recommended Model
Signal Generator	Agilent E8257D with Opt. UNX, UNT, 1EA without Opt. UNW, 1EH
50 ohm (BNC) Termination	Agilent 11593A
Power Sensor	Agilent E9304A Opt. H18 or Agilent E9304A Opt. H19
Power Meter	Agilent E4419A/B
Power Splitter	Agilent 11667A
N(m)-N(m) Cable	Agilent N6314A (p/n 8120-8862)
N(m)-N(m) Adapter	Agilent p/n 1250-1475

Receiver IF Gain/Flatness Adjustment

The purpose of this procedure is to adjust the IF gain / flatness of the A6 phase detector board.

Required equipment for the receiver IF gain/flatness adjustment

Description	Recommended Model
Signal Generator	Agilent E8257D with Opt. UNX, UNT, 1EA without Opt. UNW, 1EH
50 ohm Termination	Agilent 909C opt.012
Power Sensor	Agilent E9304A Opt. H18 or Agilent E9304A Opt. H19
Power Meter	Agilent E4419A/B
Power Splitter	Agilent 11667A
N(m)-N(m) Cable	Agilent N6314A (p/n 8120-8862)
N(m)-N(m) Adapter	Agilent p/n 1250-1475

Receiver RF Flatness Dir Adjustment

The purpose of this procedure is to adjust the RF flatness of the A6 phase detector board.

Required equipment for the receiver RF flatness adjustment

Description	Recommended Model
Signal Generator	Agilent E8257D with Opt. UNX, UNT, 1EA without Opt. UNW, 1EH
50 ohm Termination	Agilent 909C Opt. 012
Power Sensor	Agilent E9304A with Opt. H18 or Agilent E9304A Opt. H19
Power Meter	Agilent E4419A/B
Power Splitter	Agilent 11667A
N(m)-N(m) Cable	Agilent N6314A (p/n 8120-8862)
N(m)-N(m) Adapter	Agilent p/n 1250-1475

Receiver IF Gain/Flatness Dir Adjustment

The purpose of this procedure is to adjust the IF gain / flatness of the A6 phase detector board.

Required equipment for the receiver IF gain/flatness adjustment

Description	Recommended Model
Function Generator	Agilent 33250A
50 ohm Termination	Agilent 909C Opt. 012
Multimeter	Agilent 3458A, Agilent 34401A, Agilent 34410A or Agilent 34411A
Power Sensor	Agilent E9304A Opt. H18 or Agilent E9304A Opt. H19
Power Meter	Agilent E4419A/B
Power Splitter	Agilent 11667A
BNC(m)-BNC(m) Cable, 61 cm	Agilent p/n 8120-1839
Feed Thru Termination	Agilent p/n 04192-61002
BNC(f)-Banana Adapter	Agilent p/n 1251-2277
N(f)-BNC(m) Adapter	Agilent p/n 1250-1477
N(m)-BNC(f) Adapter	Agilent p/n 1250-0780
N(m)-N(m) Adapter	Agilent p/n 1250-1475

LO Sampler PLL BW Adjustment

The purpose of this procedure is to adjust the LO sampler PLL BW of the A4/A5 local synthesize modules.

Required equipment for the LO sampler PLL BW adjustment

Description	Recommended Model
Signal Generator	Agilent E8257D with Opt. UNX, UNT, 1EA without Opt. UNW, 1EH
N(m)-N(m) Cable	Agilent N6314A (p/n 8120-8862)

Phase Noise BW Adjustment

The purpose of this procedure is to adjust the phase noise BW of the phase detector board.

Required equipment for the phase noise BW adjustment

Description	Recommended Model
Signal Generator	Agilent E8257D with Opt. UNX, UNT, 1EA without Opt. UNW, 1EH
N(m)-N(m) Cable	Agilent N6314A (p/n 8120-8862)

FLL BW Adjustment

The purpose of this procedure is to adjust the frequency lock loop BW of the phase detector board.

Required equipment for the FLL BW adjustment

Description	Recommended Model
Signal Generator	Agilent E8257D with Opt. UNX, UNT, 1EA without Opt. UNW, 1EH
N(m)-N(m) Cable	Agilent N6314A (p/n 8120-8862)

Adjustment
Required Adjustment after Replacing Assembly

4 Troubleshooting

This chapter provides the procedure to isolate a faulty assembly in the E5052B.

Introduction

WARNING These servicing instructions are for use by qualified personnel only. To avoid possible electrical shock, do not perform any servicing unless you are qualified to do so.

WARNING The opening of covers or removal of parts is likely to expose dangerous voltages. Disconnect the instrument from its power supply beforehand.

CAUTION Many of the assemblies in the instrument are very susceptible to damage from ESD (electrostatic discharge). Perform the following procedures only at a static-safe workstation and wear a grounding strap.

CAUTION DO NOT operate without following instructions. Programs or files in the instrument may be broken.

How to exit from the E5052B Measurement View

You need to exit from the E5052B Measurement View to perform some troubleshooting. The following is the procedure to exit from the E5052B Measurement View.

- Step 1.** Connect the mouse and external keyboard to the connectors on the E5052B rear panel.
- Step 2.** Turn the instrument on.
- Step 3.** Press **System** key.
- Step 4.** Click **Service Menu - Administrator Menu**.
- Step 5.** Click **Exit E5052B - OK** on the menu bar. Then the E5052B exit the Measurement View, then windows desktop screen appears.

NOTE If you wish to return to the Measurement View, double-click "E5052B" icon.

NOTE If you need to shut down the E5052B and again turn on, perform in accordance with the following procedure.

- a. To get "Start" menu bar displayed, move the pointer to the bottom of the screen with mouse.
- b. Click "Start" and "Turn Off Computer", then "Turn Off Computer" dialog box opens.
- c. Select "Turn Off" button.

To Troubleshoot the Instrument

This section describes basic procedural flow of troubleshooting when servicing the E5052B. The primary procedural tool in this section is the flowchart. The flowchart contains entire troubleshooting path from a failure symptom to the isolation of faulty assembly, and will direct you to the completion of repair in an ordinary manner through the possible failure symptoms. Reference letters (Yes/No) on the flowcharts point to procedural steps that briefly explain the troubleshooting method to be performed next.

Primary Trouble Isolation

The primary trouble isolation procedure can be performed without disassembling the E5052B. Figure 4-1 shows the trouble isolation flow chart.

Step 1. Turn the instrument power on

About a few minutes after the E5052B is turned on, the measurement view is displayed on the screen. The display on the screen should be similar to Figure 4-7, “Measurement view,” on page 69.

Step 2. Check the display

- If no display appears on the LCD after the E5052B is turned on, go to “No Display troubleshooting” on page 64.
- If the E5052B stops in booting process despite something being displayed on the LCD, go to “Booting Process Troubleshooting” on page 66.
- The power-on self test is performed once automatically before the measurement starts. If the power-on self test fails, go to “Troubleshooting Using Service Function” on page 70.

Step 3. Check the basic function

If the front-panel/keyboard/mouse controls, LCD display, data storage, remote interface or another function (except for measurement part) does not work correctly, go to “Function Specific Troubleshooting” on page 75.

Step 4. Check the measurement function

If the instrument fails performance tests, go to “Performance test failure troubleshooting” on page 84.

If the measurement function does not work correctly, perform the Power On Test provided in the E5052B’s service function. When the Power On Test fails, go to “Power On Test Failure Troubleshooting” on page 73.

Figure 4-1 Primary trouble isolation flowchart

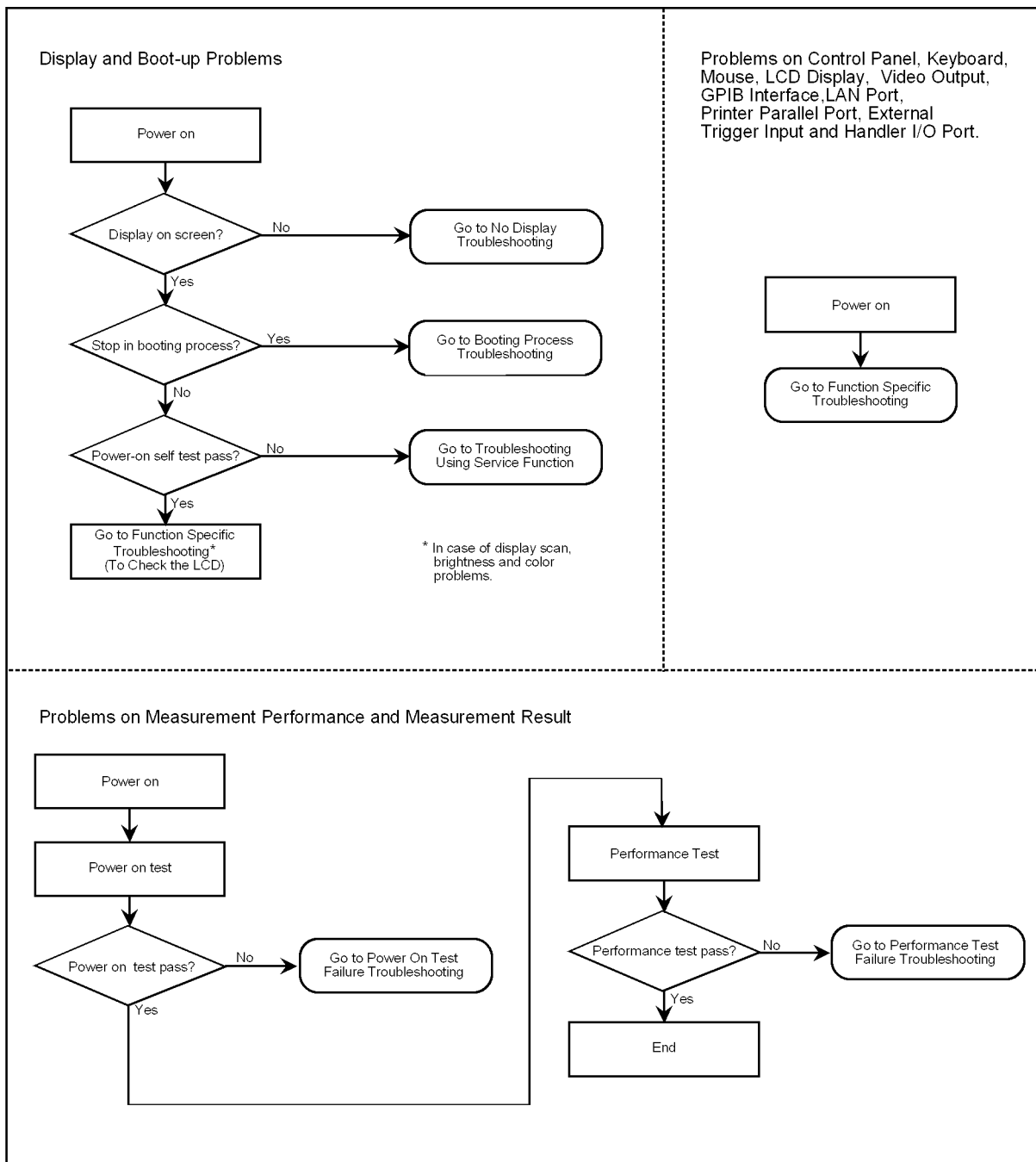

e5052ase086

No Display troubleshooting

If the E5052B displays nothing despite it is powered from proper ac power line, isolate the failure in accordance with the procedure shown in Figure 4-2.

Connect the keyboard to the E5052B rear panel connector, turn the power on and start trouble isolation. The methods of trouble isolation are described in the procedural step 1 to 6.

Figure 4-2

No display trouble isolation procedure

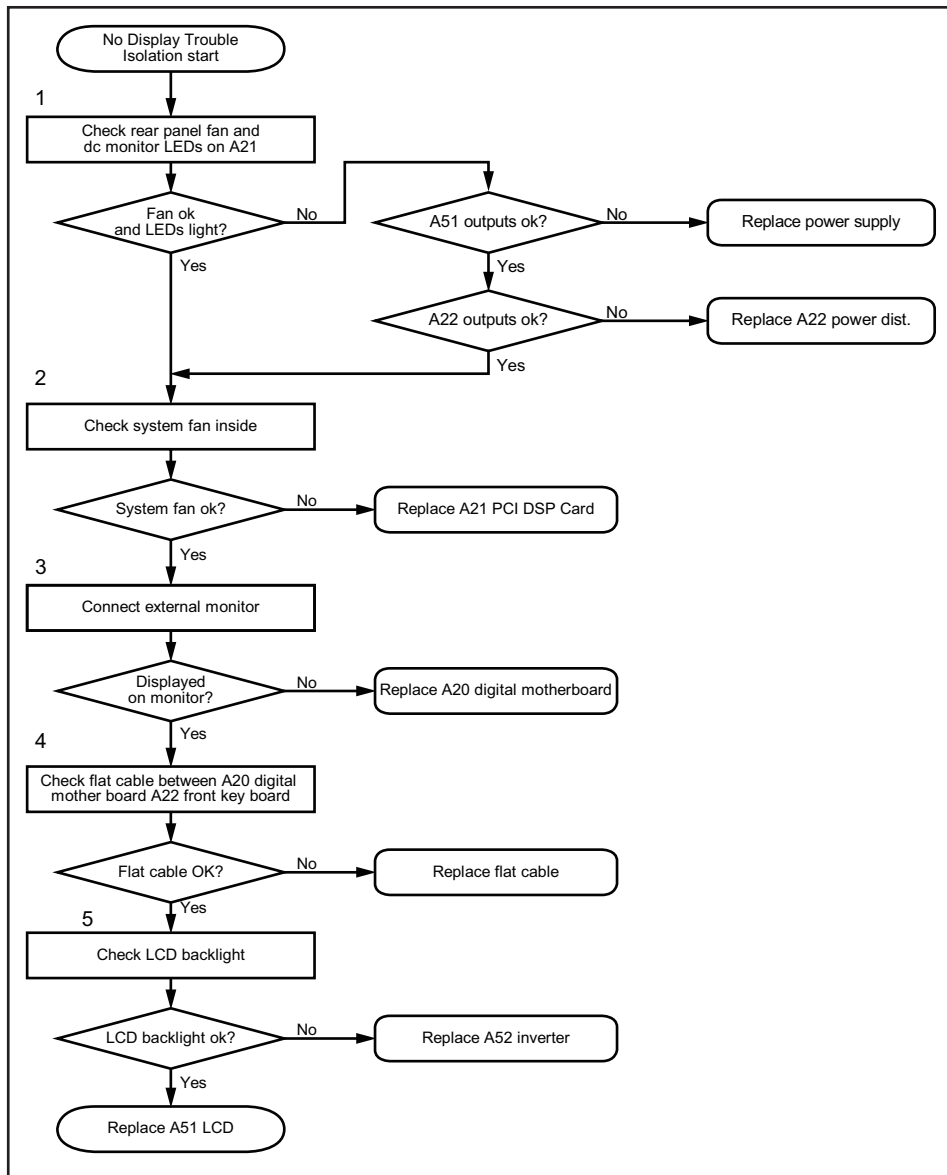

e5052bse1002

Step 1. Check fan operation and DC monitor LED

If the rear panel fan (blower) doesn't run, a failure in power supply is assumed. Remove the E5052B outer cover and check if the following LEDs light:

- +3.3 V and +5 V dc monitor LEDs on A21 PCI DSP card

NOTE

To check all the outputs of the power supply, measure the dc voltages at the output lead connectors with a DMM. The dc output voltages and lead color information is provided in the module cover label of the power supply.

To check all the outputs of the A22 power distribution board, measure the dc voltages at the voltage test pins with a DMM.

Step 2. Check system fans inside.

If the system fans on the chassis inside the E5052B don't run, problem seems in the A22 power distribution board. In this case, remove the E5052B outer cover and make sure whether the fans run or not.

NOTE

If the power shutdown occurs without a beep, the problem seems in the A22 power distribution board or the A20 digital motherboard assembly. Check BIOS status of A20 digital motherboard assembly is correct as described in “To configure the A20 Digital Motherboard and BIOS” on page 87.

Step 3. Checking with the external monitor

Connect an external XGA monitor to the VIDEO output on the E5052B rear panel.

- If something is displayed on the external monitor, the problem is present around the A51 LCD. Also check the A21 PCI DSP card and A22 front panel keyboard because the ON/OFF setting of the A51 LCD backlight is controlled by the A21 through the A22.
- If nothing is displayed even on the external monitor, the problem seems in the A20 digital motherboard.

Step 4. Checking flat cable

Check a flat cable between the A20 digital motherboard and A22 front panel keyboard.

Step 5. Check around the backlight

Check A52 inverter board and a cable between the A52 and A22 front panel keyboard. Also check the cables between the A51 LCD and A52. If the cables are normal, check the A51 LCD.

Booting Process Troubleshooting

Figure 4-3 represents the booting process flow in the E5052B. If the E5052B stops in the booting process, troubleshoot using the following step-by-step procedure.

Figure 4-3

Booting process flowchart

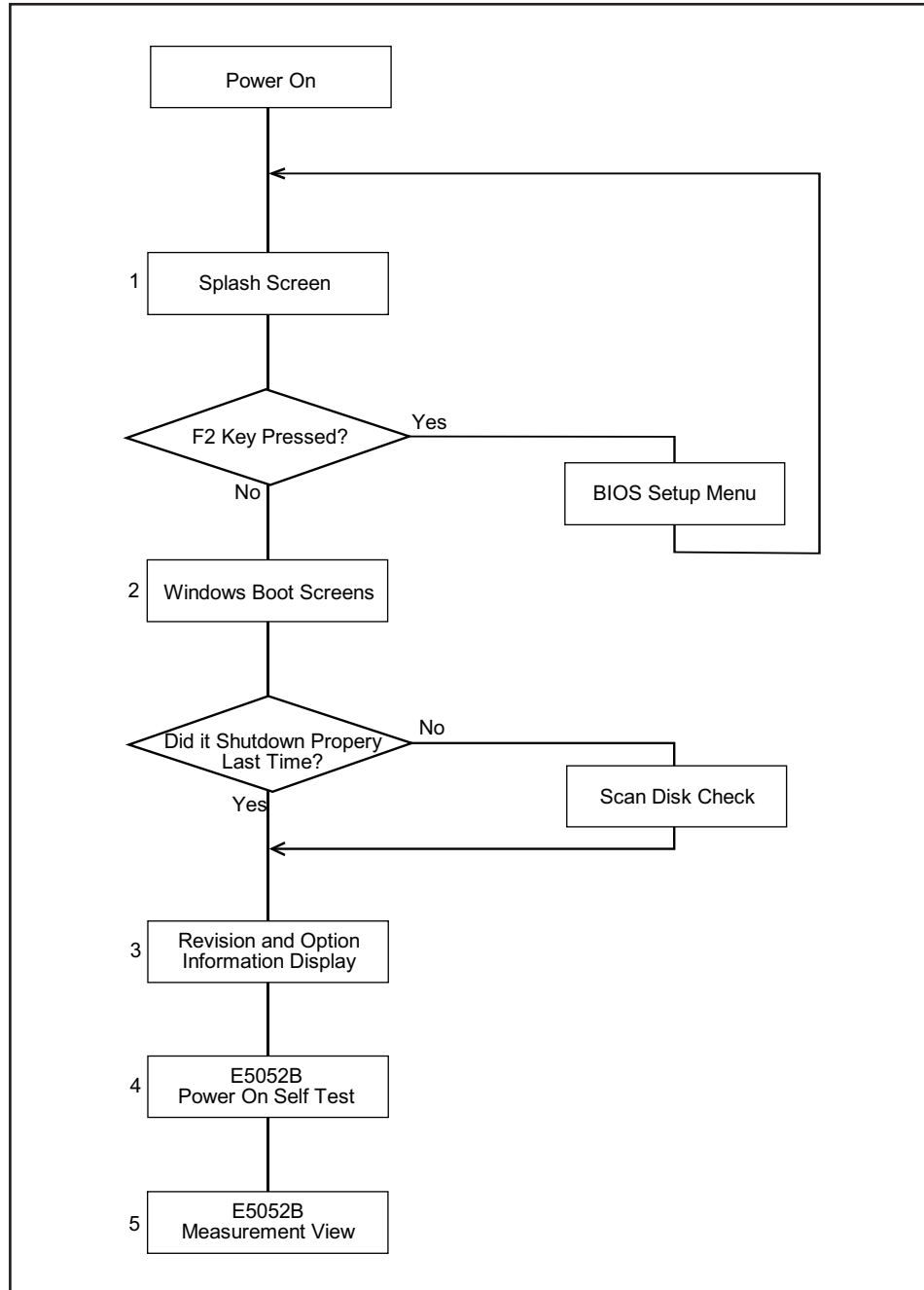

e5052bse1003

Step 1. Splash Screen

The splash screen is displayed with Agilent logo as shown in Figure 4-4.

If the splash screen is displayed, you can assume that the A20 digital motherboard is functioning correctly.

NOTE

While the splash screen is displayed, if you want to run the BIOS setup utility, press F2 key as soon as in the screen.

Figure 4-4 Splash Screen

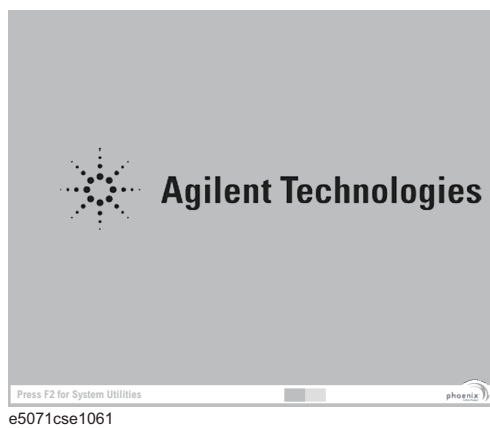

Step 2. Windows boot screens

The Windows boot screens are displayed. The Windows boot screens consist of two screens. Each screen is displayed in the order as shown in Figure 4-5. If the Windows boot screens are displayed, it is assumed that the A27 HDD works. While the Windows screens are displayed, Windows operating system is starting up.

Figure 4-5 Windows boot screens

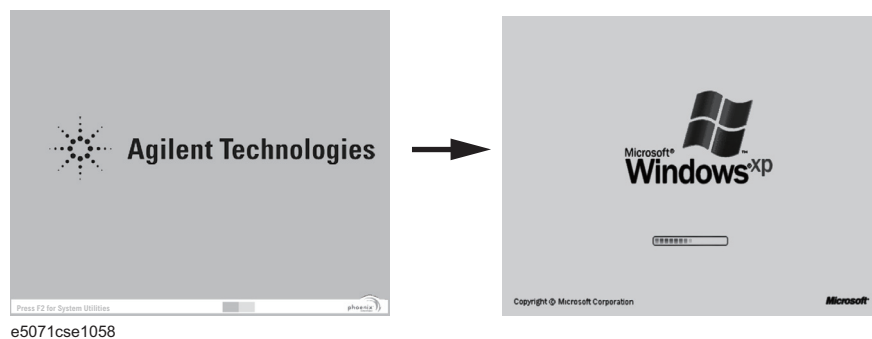

If you encounter the following problems, try to reinstall the operating system before replacing the A27 HDD.

Troubleshooting

Booting Process Troubleshooting

- "xxx file is missing" is displayed on DOS screen.
- The Windows boot screen is not displayed after the splash screen is displayed.
- Windows always boots up with Safe Mode.

NOTE

If the E5052B was turned off without shutdown process, Microsoft Scandisk runs while the windows boot screens are displayed. If a serious problem is found in the scandisk, reinstall the operating system. For details of the operating system installation, refer to Appendix B, "System Recovery," on page 207. If the operating system still doesn't boot up properly after reinstallation, replace the A27.

NOTE

The operating system automatically checks the device drivers, which are necessary to use the E5052B functions and are installed in the system before the E5052B is shipped from Agilent factory. If the operating system doesn't detect them, a message box is displayed. In this case, install the device driver.

Step 3. Revision and option information

The firmware revision and hardware option information along with copyright declaration is displayed as shown in Figure 4-6. The E5052B firmware quickly starts up just before this display appears. While the revision and option information is displayed, the applications of various devices in the system are initialized.

Figure 4-6

Firmware revision and option information



e5052bse1004

If the display whited out, entirely blued or appeared with a dialog box, a mass storage problem is suspected. Try to perform the mass storage recovery procedure.

NOTE

If a message of "Will Shut Down in Five Seconds" is displayed in place of "Initializing.." and the shutdown occurs, the A21 PCI DSP card fails in starting up. The following message may be displayed before the shutdown occurs:

"Fatal Error: Failed to Initialize DSP Driver":

or "Fatal Error: Failed to Initialize DSP":

This message indicates that the A21 PCI DSP card doesn't work or is not properly connected to the A20 digital motherboard.

"Fatal Error: Failed to Update DSP Code":

If this happened, the A21 board failed in writing DSP program into flash ROM when the firmware was installed first or updated to the newest version. A problem in the A21 or A20 is suspected.

Step 4. Power-on self test

The power-on self test is executed once automatically before the measurement starts. While the power-on self test is in progress, "Executing power on test" is displayed. If the power-on test fails, an error message is displayed at the left in the instrument status bar. For more details, refer to "Troubleshooting Using Service Function" on page 70.

Step 5. Measurement view

The measurement view as shown in Figure 4-7 is displayed after the system initialization is completed without problem.

Figure 4-7

Measurement view

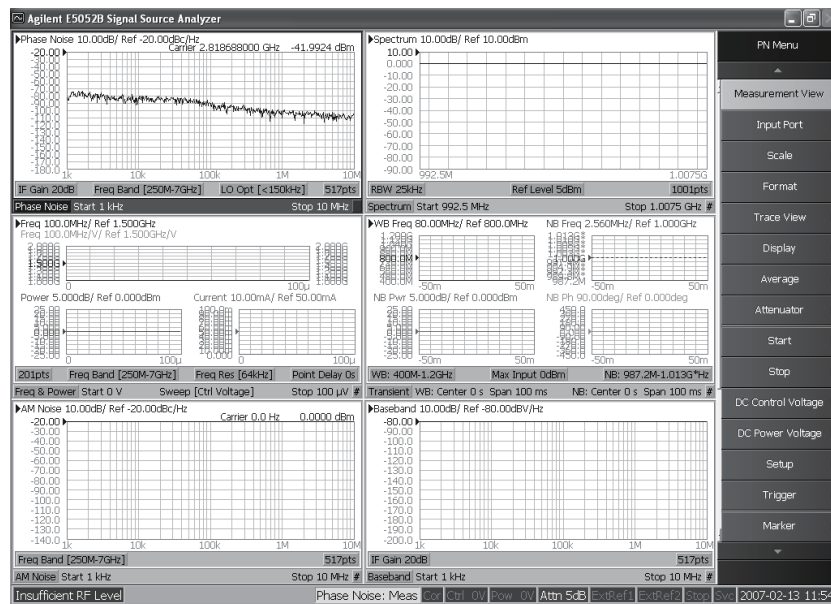

e5052bse1005

4. Troubleshooting

Troubleshooting Using Service Function

The Agilent E5052B has a service function to diagnose the analog measurement section and internal dc power supply voltages. The Power On Test of the service function makes it possible to isolate a faulty board assembly. The following paragraphs describe the procedure to perform the Power On Test.

Power On Test

Power-on self-test always takes place once the E5052B is turned on. When a failure is detected, a message "Power on self test failed" is displayed. The content of the power-on self-test includes the dc power supply voltage, source PLL synthesizer and level controller (ALC) tests. When the power on self-test failed, perform the Power On Test in Service Function Menu to narrow down failure possibilities.

The following procedure can be used to restart the power-on self test as required.

- a. Press **System** key.
- b. Click **Service Menu** and, then, click **Service Function - Service Functions** in the softkeys.
- c. Password dialog box opens. Enter the password **kid** in the Password box and then click "OK" button.
- d. Click **Service Functions**. Then click **Power On test**.
- e. Click **Execute Test** to restart the test. Wait until the power-on test ends.
- f. The test results can be displayed with result softkeys (**A1 Result** through **A6 Result**) as shown in Figure 4-8. The A1 through A6 mean the analog sections (boards) of the E5052A.

NOTE

When "hex 0" status is displayed in the results softkey, the corresponding analog section passes. When other status is displayed in the results softkey, the corresponding analog section fails.

Figure 4-8 Power On Test softkey menu

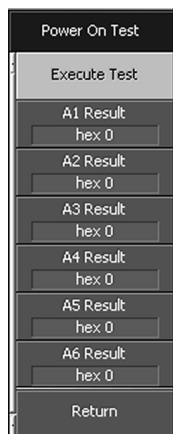

e5052ase089

Contents of the power on test results

The power on test contains 6 test results shown in Figure 4-8. Each test result can display various operating characteristics of the analog measurement section. You can identify a failure section with the test results. When the Power On Test is done, “true” or “false” is indicated for each test item.

A1 Result

Figure 4-9 is an example of the A1 Result.

Figure 4-9

A1 Result example

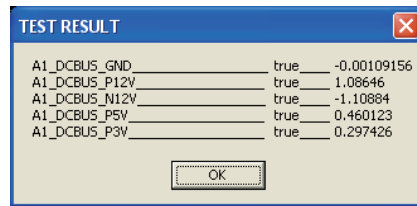

e5052bse1006

A2 Result

Figure 4-10 is an example of the A2 Result.

Figure 4-10

A2 Result example

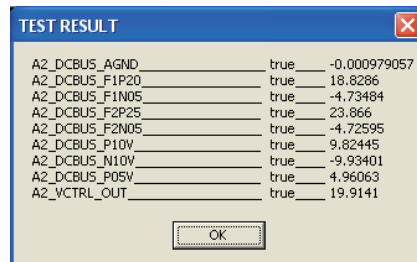

e5052bse1007

A3 Result

Figure 4-11 is an example of the A3 Result.

Figure 4-11 A3 Result example

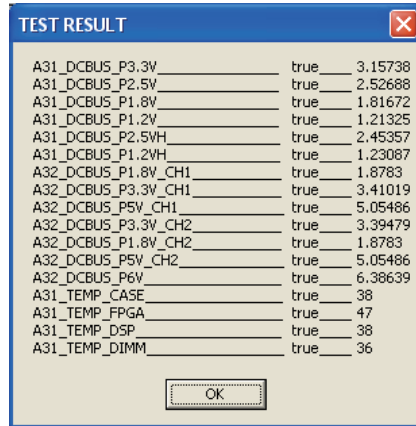

e5052bse1008

A4 Result

Figure 4-12 is an example of the A4 Result.

Figure 4-12 A4 Result example

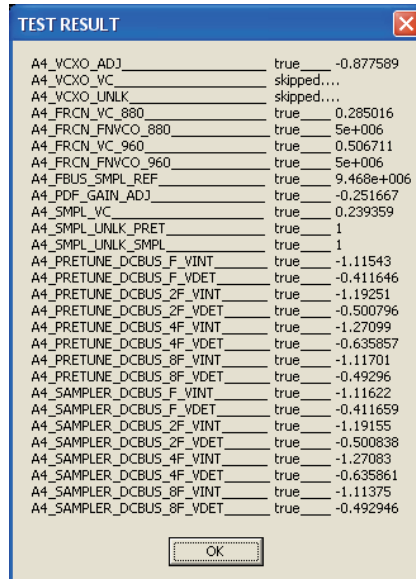

e5052bse1009

A5 Result

Figure 4-13 is an example of the A5 Result.

Figure 4-13

A5 Result example

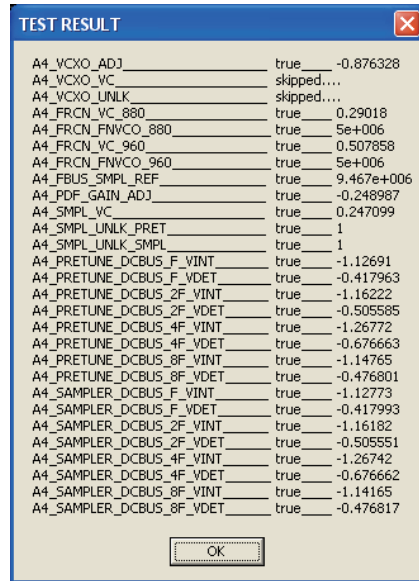

e5052bse1010

A6 Result

Figure 4-14 is an example of the A6 Result.

Figure 4-14

A6 Result example

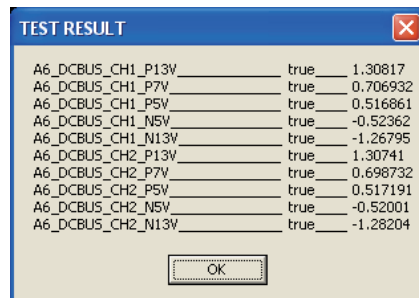

e5052bse1011

Power On Test Failure Troubleshooting

Table 4-1 represents the contents of the test results and the relationships of failed tests to probable faulty board assemblies. If the instrument fails the power on test, replace the faulty board assembly as shown in Table 4-1.

Table 4-1

Power on test failure troubleshooting information

Test result	Probable faulty board assembly					
	A1 F/P Detect	A2 DC Source	A3 ADC/DSP	A4 Local Synth	A5 Local Synth	A6 Phase Detect
A1 Result	###					

Table 4-1 Power on test failure troubleshooting information

Test result	Probable faulty board assembly					
	A1 F/P Detect	A2 DC Source	A3 ADC/DSP	A4 Local Synth	A5 Local Synth	A6 Phase Detect
A2 Result	#	###				
A3 Result	#		###			
A4 Result	#			###		
A5 Result	#				###	
A6 Result	#					###

###: Most suspicious assembly

##: Suspicious assembly

#: Possible faulty assembly

Function Specific Troubleshooting

If the E5052B exhibits a failure symptom that is related to a specific function or control such as a front panel key control, display, data storage, remote control interface, printer interface, external trigger, external keyboard or mouse, isolate the trouble using the Function Specific Troubleshooting procedures described below. The major functions of the E5052B and the troubleshooting procedure for each function are shown in Table 4-2.

Table 4-2 Major functions and troubleshooting procedures

Function	Description	Troubleshooting
Front panel keys	All the E5052B functions except for VBA and service functions can be set and controlled via the front panel keys.	Refer to “To Check the Front Panel” on page 78.
Touch panel	The E5052B has a touch screen display that allows all the functions in the menu bars, setup windows and dialog boxes to be set by a touch to the screen panel.	Refer to “To Check the Touch Panel” on page 79.
LCD display	Almost all the information including the measurement value, setup state, result data processing, menu bar, softkey label and others are indicated on the 10.4-inch color LCD display.	Refer to “To Check the LCD” on page 79.
External keyboard	The external keyboard can be used for the entry of numerical and character data when it is connected to the keyboard interface connector (USB) on the rear panel.	Refer to “To Check the External Keyboard” on page 80.
Mouse	The mouse can be used to move the pointer on the LCD display, select a function and change a setting, when it is connected to the mouse interface connector (USB) on the rear panel.	Refer to “To Check the Mouse” on page 80.
Video output	An external color monitor can be used to display the same information as the E5052B LCD display, when it is connected to the Video output connector (24-pin D-Sub) on the rear panel.	Refer to “To Check the Video output” on page 80.
External trigger input	The external trigger input terminal (BNC) on the rear panel allows an external trigger source to be used for measurement trigger.	Refer to “To Check the External Trigger Input” on page 80.
GPIB Interface	The GPIB compatibility allows the E5052B to be operated as a talker/listener on IEEE 488 interface bus.	Refer to “To Check the GPIB” on page 81.
24-bit I/O port	The 24-bit I/O port can be used to transfer a comparator decision output data to and perform timing synchronization with an external handler.	Refer to in “To Check the 24-bit I/O port” on page 81.

Table 4-2 Major functions and troubleshooting procedures

Function	Description	Troubleshooting
Oven	A 10 MHz high stability signal is outputted.	Refer to in “To Check the Oven Ch1” on page 81 or “To Check the Oven Ch2” on page 82.
USB (USBTMC) Interface	The GPIB compatibility allows the E5052B to be operated as a talker/listener on IEEE 488 interface bus.	Refer to in “To Check the USB (USBTMC) Interface Card” on page 82.

To Check the Device Driver

Make sure first whether the E5052B device drivers are installed properly or not by the following procedure, if a function of specific device in the E5052B doesn't work.

- Step 1.** Exit from the E5052B measurement view in accordance with the procedure described in “How to exit from the E5052B Measurement View” on page 61. Then, Windows desktop screen is displayed.
- Step 2.** Right-click "My Computer" and select "Properties" as shown in Figure 4-15. Then, the System Properties (Figure 4-16) will appear.

Figure 4-15 Opening System Property Window



e5052bse1012

Figure 4-16 System Properties Window (General)



e5052bse1013

Step 3. Click Hardware tab and Device Manager button. The operating system detects all the necessary device drivers and displays the device names as shown in Figure 4-17.

Figure 4-17 System Properties Window (Hardware)

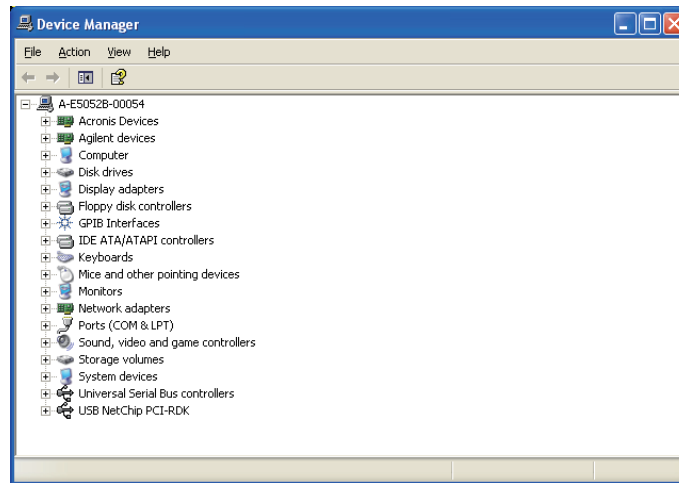

e5052bse1014

Right-click the icon and select Property to show the detail of the status as shown in Figure 4-18.

Figure 4-18 Opening Device Driver Property

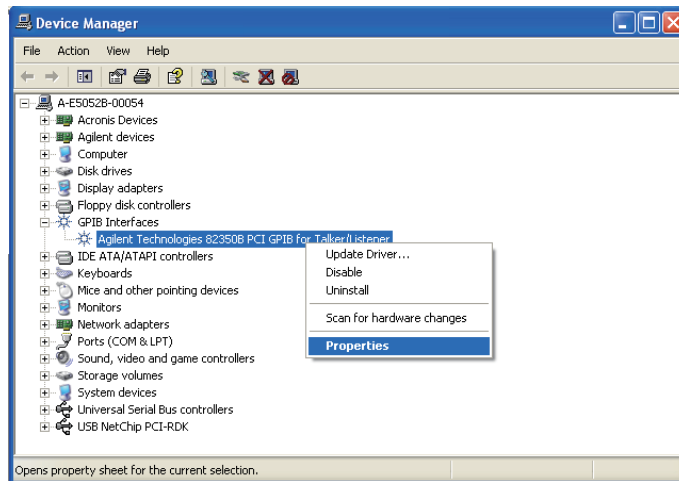

e5052bse1015

To Check the Front Panel

Procedure

Randomly press the front panel keys and rotate the knob to verify that they work normally.

- Step 1.** Press **System** key.
- Step 2.** Click **Service Menu** and, then, **Test Menu** in the softkeys.
- Step 3.** Click **Front Panel** in the test menu. This opens "Front Panel Test" dialog box as shown in Figure 4-19.

Figure 4-19 Front Panel Test dialog box

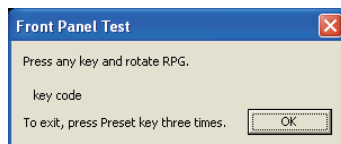

e5052bse1017

- Step 4.** Randomly press the front panel keys. The key code along with the name of the pressed key are displayed in the dialog box as shown in Figure 4-20. Turn the rotary knob clockwise or counterclockwise. The dialog box indicates the direction of the turned knob and a count of RPG output.

Figure 4-20 Key code and key name display example

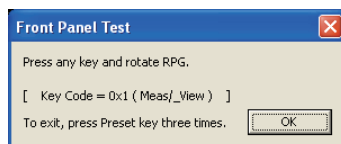

e5052bse1016

Step 5. To exit the front panel test, press **[Preset]** key three times.

- If multiple keys fail to work, a problem in A22 front panel keyboard or A21 PCI DSP card is suspected. Also check the flat cable between the A21 and A22.
- If only a specific key doesn't work, check first if the key is subsided in the panel.
- If the rotary knob doesn't work, check the A22 board involving the RPG.

To Check the Touch Panel

Procedure

By touching the LCD display panel, select or change the setting of a function in the softkey menu and, then, perform the same operation with hardkeys.

- If the touch panel doesn't work correctly whereas the hardkeys function normally, a failure seems in the touch screen controller assembly (5183-4184) or touch-panel LCD assembly (E5070-60112). (The touch panel is not replaceable independently of the LCD.)
- Check the cable between the touch screen controller and the serial interface connector on the A20 digital motherboard.
- If no problem is found in the above checks, a failure in the A20 digital motherboard is suspected.

To Check the LCD

Procedure

Step 1. Press **[System]** key.

Step 2. Click **Service Menu** and, then, **Test Menu** in the softkeys menu.

Step 3. Click **Display Test** in the test menu. The whole of the LCD screen turns Red, Green, Blue, White and Black every 2 seconds and returns to the measurement view. If the color test screen doesn't appear correctly, perform step 4.

Step 4. Connect an external XGA monitor to the VIDEO output port on the E5052B rear panel.

- If the monitor screen view is the same as the LCD display, the problem seems in the A21 PCA DSP Card. Check first if the A21 is securely connected to the A20 Digital Moterboard Assembly.
- If only the LCD display has a problem, check the flat cable between the A22 front panel keyboard and A26 Digital Bridge Board.
- If the LCD is not illuminated with backlight, check A52 inverter board and the cable between the A52 and A22. Also check the cables between the A51 LCD and A52.
- If the cables are normal, check the A51 LCD.

To Check the External Keyboard

Procedure

- Step 1.** Connect the external keyboard to the E5052B rear panel connector.
- Step 2.** Turn the instrument on.
- Step 3.** Press **Meas/View** key.
- Step 4.** Press **↑** and **↓** keys on the external keyboard, and verify that the cursor on the menu bar moves up and down. If it doesn't work, the external keyboard or the A20 digital motherboard may be faulty.

To Check the Mouse

Procedure

- Step 1.** Connect the mouse to the E5052B rear panel connector.
- Step 2.** Turn the instrument on.
- Step 3.** Move the mouse and verify that the mouse pointer moves smoothly. If it doesn't move smoothly, check first whether a foreign substance (dust, lint, etc.) is in the track ball hole of the mouse or not.
- Step 4.** Verify that the mouse buttons work normally. If any button doesn't work or the mouse pointer doesn't move, a failure in the mouse or the A20 digital motherboard is suspected.

To Check the Video output

Procedure

- Step 1.** Connect an external XGA color monitor to the Video output port on the E5052B rear panel.
- Step 2.** Turn the external monitor on.
- Step 3.** Verify that the monitor screen view is the same as the display on the LCD. If the monitor screen view is abnormal, a failure seems in the A21 PCI DSP Board.

To Check the External Trigger Input

Procedure

- Step 1.** Press **Preset** - **Factory** to initialize the E5052B.
- Step 2.** Press **Trigger** key.
- Step 3.** Click **Source** and then, **External** in the menu bar to set the trigger mode to "External".
- Step 4.** Connect a BNC Short or 50 Ω termination to the Ext Trig connector on the rear panel and disconnect it. Thereby a measurement trigger should be generated and a measurement result (trace) should be refreshed.
- Step 5.** If no trigger occurs, a failure in the A21 PCI DSP card is suspected.

To Check the GPIB

Procedure

Perform the E5052B performance test program. If the controller cannot detect the E5052B, the problem seems in the A24 GPIB card or the connection of the GPIB cable.

To Check the 24-bit I/O port

Procedure

This check is performed using a handler I/O test kit (p/n E5070-65001) as a substitute for the handler.

- Step 1.** Connect the flat cable of handler I/O test kit to “J2” connector of the kit.
- Step 2.** Connect the cable of the kit to the 24-bit I/O port connector on the rear panel.
- Step 3.** Check the 24-bit I/O port by executing “24bitI-Otest.vba”.

NOTE

The program “24bitI-Otest.vba” can be downloaded from the Agilent Technologies website to USB Mass Storage Device.

- Step 4.** If the check failed, a failure in the A23 24-bit I/O board is suspected.

To Check the Oven Ch1

Procedure

This check is performed using a PSG.

Check the Oven Ch2 before you start the Oven Ch1.

- Step 1.** Press **[Preset] - Factory** to initialize the E5052B, then set the E5052B as follows.

E5052B settings	Key strokes
Measurement View : FP	[Meas/View] - Freq & Power
Mode : Tester	[Trigger] - Mode - Tester
Trigger Mode : Hold	[Trigger] - Trigger to Freq & Power
Frequency Band : 250 M - 7 GHz	[Setup] - Frequency Band - 250M-7GHz
Frequency Resolution : 10 Hz	[Setup] - Freq Resolution - 10Hz
Number of Average: 16	[Avg/BW] - Ave Factor - [1] - [6] - [x1]
Averaging Mode : ON	[Ave/BW] - Averaging ON off
Service Function : Ch1	[System] - Service Menu - Service Function - FP - CHANnel - Chan1

Troubleshooting
Function Specific Troubleshooting

Step 2. Preset the PSG. Then set the PSG as follows.

Instrument	Setting
Signal Generator	Frequency : 1 GHz Power : 0 dBm, RF Output : ON

Step 3. Press **[Trigger] - Continuous**, and **[Avg/BW] - Averaging Restart** to make a measurement. Wait until a trace for the average of 16 swept measurements is displayed.

NOTE

The number of averaging times is displayed in the averaging status (lower right) of the measurement windows.

Step 4. Press **[Trigger] - Hold** of the E5052B to make a measurement.

Step 5. Note the E5052B reading as Frequency value.

Step 6. Set the E5052B as follow.

E5052B settings	Key strokes
Service Function : Ch2	[System] - Service Menu - Service Function - FP - CHANNEL - Chan2

Step 7. Repeat Step 3 through Step 5.

Step 8. Calculate the following formula:

$$\text{Test Result (Hz)} = \text{frequency value Ch2} - \text{Frequency value Ch1}$$

Step 9. Verify that the test result is 500 Hz \pm 150 Hz.

Step 10. If the check failed, a failure in the Oven Ch1 is suspected.

To Check the Oven Ch2

Procedure

This check is performed using a frequency counter and a power meter.

Step 1. Connect the frequency counter to the Ext Ref Out connector, and then verify that the frequency value is 10 MHz \pm 50 Hz.

Step 2. Connect the power meter to the Ext Ref Out connector, and then verify that the power value is 2.5 dBm \pm 3 dB.

Step 3. If the check failed, a failure in the Oven Ch2 is suspected.

To Check the USB (USBTMC) Interface Card

Procedure

Connect the USB cable between the controller PC and the E5052B. Turn the controller PC on. If the E5052B cannot detect the controller PC, the problem seems in the A32 USB

(USBTMC) Interface Card or the A20 digital motherboard is suspected.

Performance test failure troubleshooting

This section describes the adjustment and troubleshooting procedures used when the E5052B fails the performance tests. If the performance of the instrument is critical for the test limits and seems to be adjustable, perform first the adjustment(s) related to the failed test. When the test result is far from the tolerance of the test or the performance is not adjustable, isolate the faulty assembly in accordance with the "Performance tests failure troubleshooting procedure".

Recommended adjustment for performance test failure

Table 4-3 shows the recommended adjustments when the performance test fails. Select the adjustment program corresponding to the recommended adjustment and perform the adjustment. Note that adjustment items for the A3 or A4/5 are the same as the A6.

When RF IN Port VSWR test fails, check first whether the connections of the RF semi-rigid cables are tight or loose. Also check for possible disconnection (impairment) of the cables and connectors.

Table 4-3

Recommended adjustment for performance test failure

Test Num.	First failed test	Recommended adjustment				
		A1	A2	A3	A4/5	A6
1	RF IN Port VSWR Test					
2	Frequency Measurement Test	√				√
3	Power Measurement Accuracy Test	√				
4	Phase Noise Accuracy Test					√
5	SSB Phase Noise Sensitivity Test					√
6	SA Relative Level Accuracy Test					√
7	DC Power Voltage Test		√			
8	DC Power Current Measurement Test		√			

Adjustment failure troubleshooting

Table 4-4 represents the relationships between the failed adjustment and probably faulty assembly. Note that this table lists some typical cases. There are possibilities that another assembly may be faulty.

Table 4-4 Adjustment failure troubleshooting information

Adj Num.	First failed adjustment	Probable faulty board assembly				
		A1	A2	A3	A4/5	A6
1	DC Control Voltage		###			
2	DC Power Voltage		###			
3	DC Power Current	###	##			
4	Reference Frequency	#			###	
5	Pre-LO Sampler PLL BW				###	
6	Receiver DC offset			#		###
7	PM Offset	###				
8	PM Linearity	###				
9	PM Temp	###				
10	PM Flatness	###				
11	Receiver RF Flatness	#		##	#	###
12	Receiver IF Gain/Flatness			##	#	###
13	Receiver RF Dir Flatness	#		##	#	###
14	Receiver IF Dir Gain/Flatness			##	#	###
15	LO Sampler PLL BW	#		##	#	###
16	Phase Noise BW			#	###	#
17	FLL BW			#	###	#

###: Most suspicious assembly

##: Suspicious assembly

#: Possible faulty assembly

Performance test failure troubleshooting

Table 4-5 represents the relationships between the failed test and probable faulty assembly. If the performance test failure cannot be removed by a proper adjustment, replace the assembly shown in this table.

Note that this table lists some typical cases. There are possibilities that another assembly may be faulty.

Troubleshooting
Performance test failure troubleshooting

NOTE

When RF IN Port VSWR test fails, check first whether the connections of the RF semi-rigid cables between the suspicious assembly and others are tight or loose. Also check for possible disconnection (impairment) of the cables and connectors.

Table 4-5 Performance test failure troubleshooting information

Test No.	First failed test	Probable faulty board assembly					
		A1	A2	A3	A4	A5	A6
1	RF IN Port VSWR Test	###					
2	Frequency Measurement Test	##		#		#	###
3	Power Meas. Accuracy Test	###					
4	Phase Noise Accuracy Test			#	##	##	###
5	SSB Phase Noise Sensitivity Test			#	##	##	###
6	SA Relative Level Accuracy Test			#		##	###
7	DC Power Voltage Test		###				
8	DC Power Current Meas. Test	#	###				

###: Most suspicious assembly

##: Suspicious assembly

#: Possible faulty assembly

To configure the A20 Digital Motherboard and BIOS

When you replace the A20 digital motherboard, you need to confirm the BIOS options using the BIOS setup utility procedure. The BIOS setup procedure is described in “To Confirm or Set the BIOS Options” on page 88.

To Identify the Motherboard Installed

Confirm the splash screen is displayed in the beginning of the boot process as shown in Figure 4-4.

Testing DRAM on the Motherboard

When the A20 digital motherboard is replaced with a new one, it is advisable to perform the DRAM test before proceeding to the BIOS setup utility procedure. Confirm the DRAM count in accordance with the following procedure.

- Step 1.** Connect the external keyboard and mouse to the E5052B rear panel connectors.
- Step 2.** Turn the instrument on. Wait until the E5052B boots up. Do not press any key until the E5052B measurement view appears.
- Step 3.** Press **[System]** key on the front panel.
- Step 4.** Click **Misc Setup** in the softkey menu.
- Step 5.** Click **Control Panel...** in the softkey menu.
- Step 6.** Scroll the function viewer to find "System" icon and double-click "System". This opens "System Properties" window as shown in Figure 4-21.

Figure 4-21 System Properties window

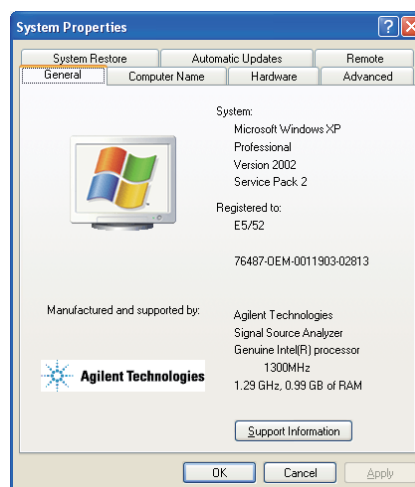

e5052bse1013

- Step 7.** Verify that "0.99 GB RAM" is displayed in the Computer profile as shown in Figure 4-21.

If it is not correct, the A20 board is faulty.

Step 8. Click "OK" button to close the window.

Step 9. Turn the E5052B off before proceeding to the next step “To Confirm or Set the BIOS Options”.

To Confirm or Set the BIOS Options

BIOS is the PC's built-in program describing the standard procedure of basic inputs and outputs for the system hardware. BIOS involves the system BIOS, start-up program and BIOS setup utility. The E5052B starts up first with the BIOS when the power is turned on. Use the following procedure to confirm or set the BIOS options, known as the BIOS setup utility.

Run the BIOS setup utility

Use the external keyboard to select and set various options in the BIOS setup utility. Do not operate the E5052B front panel until you exit the BIOS option setup procedure.

Procedure Step 1. Connect the external keyboard to the E5052B rear panel connector.

Step 2. Turn the instrument on.

Step 3. Press F2 key as soon as the splash screen as shown in Figure 4-4 is displayed. Wait a few seconds until the message "Enter CURRENT Password:" appears.

Step 4. Press  key (The LED in the key lights.)

Step 5. Enter the password "e5052" and press . Then BIOS setup utility main menu is displayed as shown in Figure 4-22.

Figure 4-22

BIOS setup utility main menu

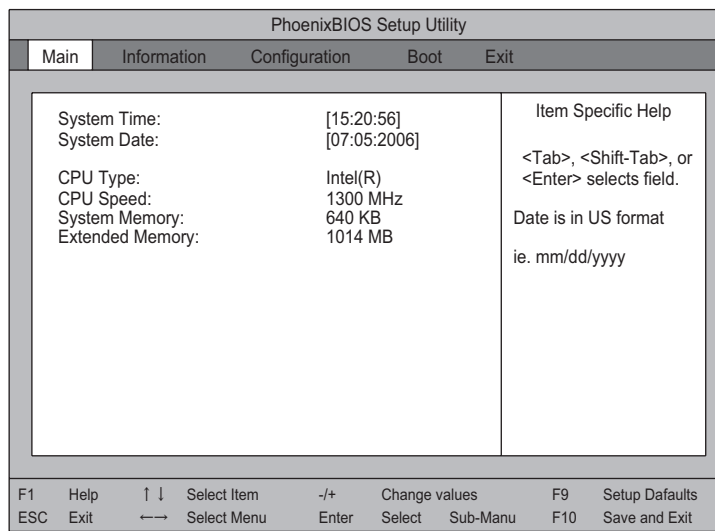

Step 6. The BIOS setup utility has primary menus, most of which have sub-menus. Brief

To configure the A20 Digital Motherboard and BIOS

descriptions for these menus are provided in Table 4-6. It is recommended not to change any value except for the case of replacing A20 digital motherboard assembly.

Step 7. Select a desired menu using **←** **→** keys. Select an item in the menu or sub-menu window using **↑** **↓** keys. To perform an operation, use **Enter** key.

NOTE

If you want to exit the BIOS option setting and exit the BIOS setup utility without saving changes in the setup, select "Exit Discarding Changes" and press **Enter** key at the Exit Menu.

Table 4-6

BIOS setup utility primary menus and references

Menu	Options
Main	System Time System Date CPU Type CPU Speed System Memory Extended Memory
Information	Version Information System Monitors
Configuration	IDE Devices Configuration Diskette Options Video Configuration USB Configuration LAN Configuration PCI Expansion Slot Configuration Peripheral Configuration Power Control Configuration Security Configuration System Monitors Configuration Advanced Configuration Console Redirection

Table 4-6

BIOS setup utility primary menus and references

Menu	Options
Boot	Floppy check Summary screen Boot-time Diagnostics Logo Video Mode Installed OS Enable ACPI POST Errors
Exit	Exit Saving Changes Exit Discarding Changes Load setup Defaults Discard Changes Save Changes CMOS Restore Condition Save CMOS to Flash Erace CMOS from Flash Restore CMOS from Flash

Load Setup Defaults

NOTE

Perform the following procedure only when the A20 digital motherboard is replaced.

Exit menu shown below is displayed by choosing "Exit" using keys and by pressing key at the BIOS Setup Utility main menu. Select "Load Setup Default" using keys. The dialog box "Setup Confirmation" prompts you to select Y (Yes) or N (No). Press and to load the manufacture Setup Defaults into the BIOS ROM. As a result, almost all of the BIOS options are automatically configured to the optimal settings for the E5052B.

Exit Without Saving

If you cancel the changes in the BIOS option settings, select "Exit Discarding Change" using keys at the Exit Menu and press key. Then, a message of "Quit Without Saving (Y/N)?" is displayed. Press and keys.

The BIOS setup utility is closed without saving the current settings.

5 **Replaceable Parts**

This chapter contains information for ordering replacement parts for the E5052B.

Ordering Information

To order a part in the replaceable parts lists, quote the Agilent Technologies part number, indicate the quantity required, and address the order to the nearest Agilent Technologies Sales Office.

To order a part not listed in the replaceable parts lists, include the instrument model number, the description and function of the part, and the quantity of parts required. Address the order to the nearest Agilent Technologies Sales Office.

Direct Mail Order System

Within the USA, Agilent Technologies can supply parts through a direct mail order system. There are several advantages to this system:

- Direct ordering and shipping from the Agilent Technologies parts center in California, USA.
- No maximum or minimum on any mail order. (There is a minimum amount for parts ordered through a local Agilent Technologies Sales Office when the orders require billing and invoicing.)
- Prepaid transportation. (There is a small handling charge for each order.)
- No invoices.

In order for Agilent Technologies to provide these advantages, please send a check or money order with each order.

Mail order forms and specific ordering information are available through your local Agilent Technologies Sales Office. Addresses and telephone numbers are located in a separate document shipped with the manuals.

Exchange Assemblies







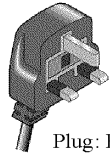
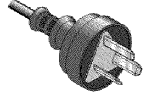

Under the rebuilt-exchange assembly program, certain factory-repaired and tested assemblies are available on a trade-in basis. These assemblies are offered at lower cost than a new assembly, but meet all factory specifications required of a new assembly.

The defective assembly must be returned for credit under the terms of the rebuilt-exchange assembly program. Any spare assembly stock desired should be ordered using the new assembly part number.

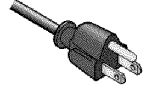
Replaceable Parts List

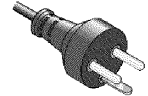
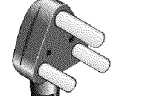
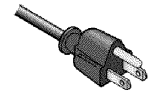
Power Cables and Plug Configurations

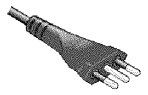
Figure 5-1 Power Cables and Plug Configurations

<p>OPTION 900</p>  <p>United Kingdom</p> <p>Plug: BS 1363/A, 250V, 10A Cable: 8120-1351, 8120-8705</p>	<p>OPTION 901</p>  <p>Australia/New Zealand</p> <p>Plug: AS 3112, 250V, 10A Cable: 8120-1369</p>
<p>OPTION 902</p>  <p>Continental Europe</p> <p>Plug: CEE 7 Standard Sheet VII, 250V, 10A Cable: 8120-1689</p>	<p>OPTION 903</p>  <p>U.S./Canada</p> <p>Plug: NEMA 5-15P, 125V, 10A Cable: 8120-1378</p>
<p>OPTION 904</p>  <p>U.S./Canada</p> <p>Plug: NEMA 6-15P, 250V, 6A Cable: 8120-0698</p>	<p>OPTION 906</p>  <p>Switzerland</p> <p>Plug: SEV Type 12, 250V, 10A Cable: 8120-2104</p>
<p>OPTION 912</p>  <p>Denmark</p> <p>Plug: SR 107-2-D, 250V, 10A Cable: 8120-2956</p>	<p>OPTION 917</p>  <p>India/Republic of S. Africa</p> <p>Plug: IEC 83-B1, 250V, 10A Cable: 8120-4211</p>
<p>OPTION 918</p>  <p>Japan</p> <p>Plug: JIS C 8303, 125V, 12A Cable: 8120-4753</p>	<p>OPTION 920</p>  <p>Argentina</p> <p>Plug: Argentine Resolution 63, Annex IV, 250V, 10A Cable: 8120-6870</p>
<p>OPTION 921</p>  <p>Chile</p> <p>Plug: CEI 23-16, 250V, 10A Cable: 8120-6978</p>	<p>OPTION 922</p>  <p>China</p> <p>Plug: GB 1002, 250V, 10A Cable: 8120-8376</p>
<p>NOTE: Each option number includes a 'family' of cords and connectors of various materials and plug body configurations (straight, 90° etc.).</p>	

power_e

Top View (Major Assemblies)

Figure 5-2 Top View (Major Assemblies)

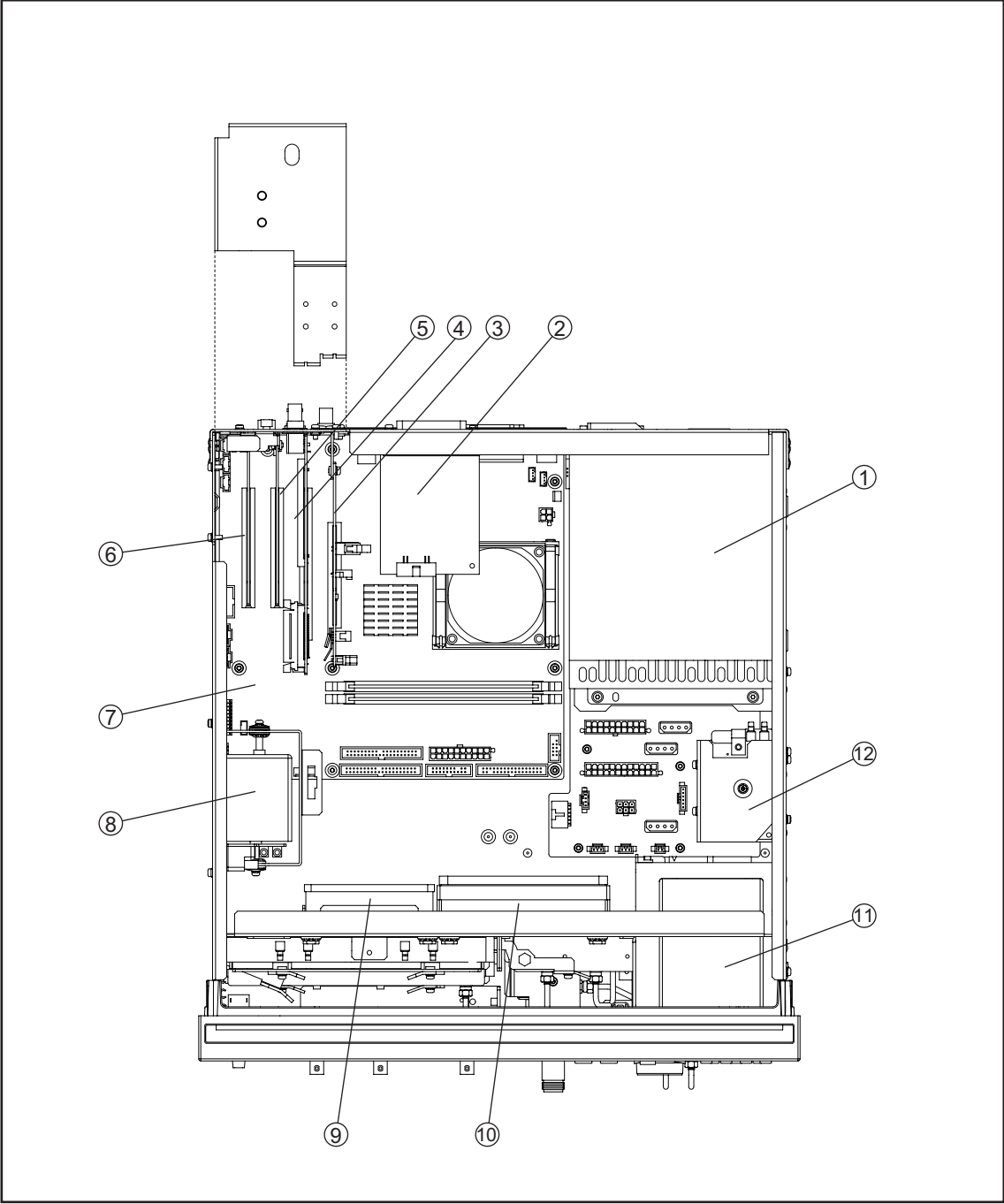

e5052bse1034

Table 5-1 Top View (Major Assemblies)

Ref. Desig.	Agilent Part Number	Qty.	Description
1	0950-4899	1	POWER SUPPLY
2	E5052-66525	1	A23 24BIT I/O BOARD
3	See Table 5-18	1	A26 PCA DIGITAL BOARD
4	See Table 5-16	1	A21 PCI DSP CARD ASSY
5	See Table 5-16	1	A24 GPIB CARD ASSY
6	See Table 5-17	1	A32 USB(USBTMC) INTERFACE CARD ASSY
7	E5052- 61011	1	A20 DIGITAL MOTHERBOARD
8	See Table 5-20	1	OVEN CH2 ASSY
9	E5052-61647	1	FAN ASSY
10	E5052-61646	1	FAN ASSY
11	See Table 5-15	1	A27 REMOVABLE HARD DISK DRIVE ASSY
12	See Table 5-19	1	OVEN CH1 ASSY

Top View (Cables)

Figure 5-3 Top View (Cables)

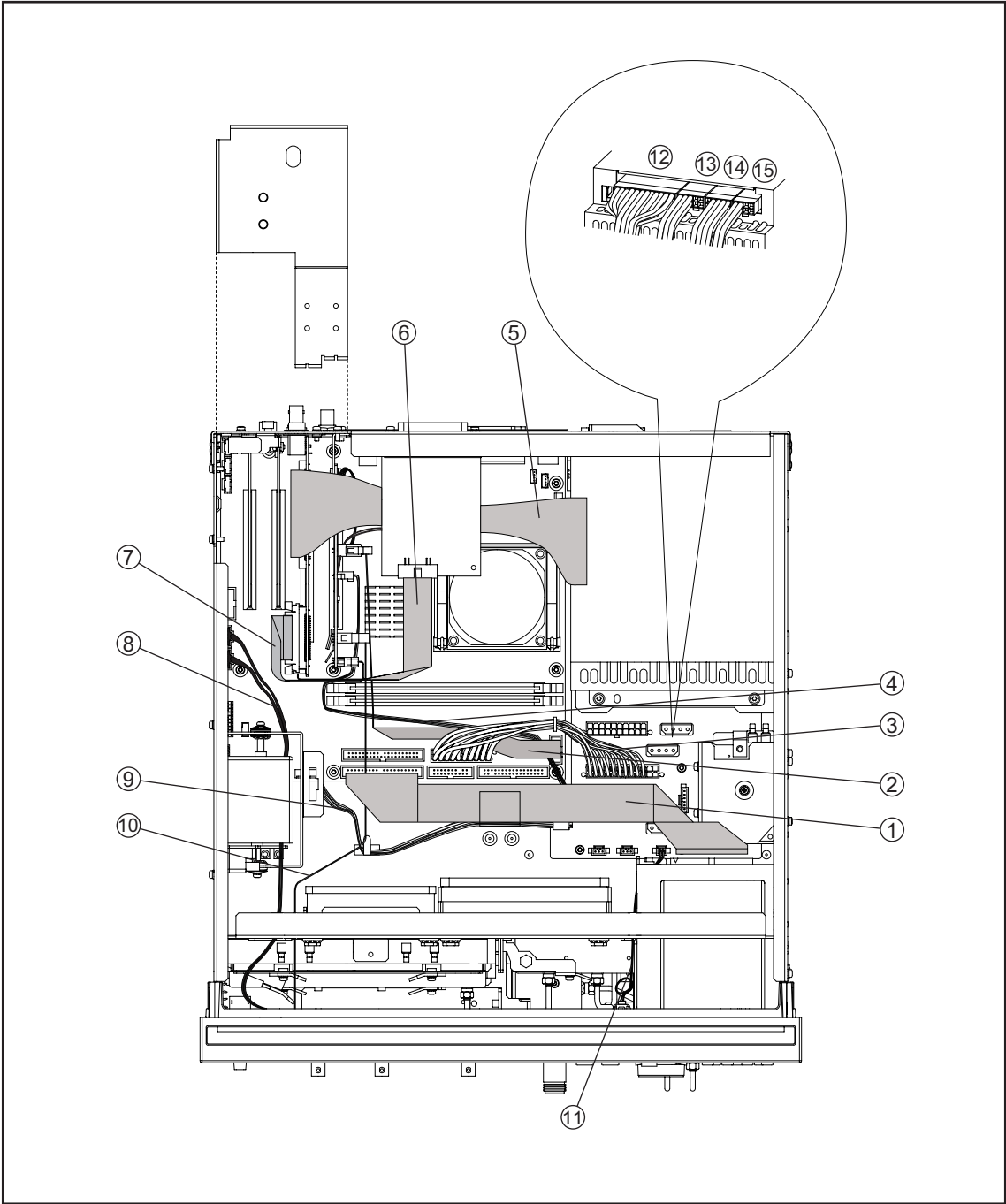

e5052bse1035

Table 5-2 Top View (Cables)

Ref. Desig.	Agilent Part Number	Qty.	Description
1	E5052-61685	1	FLAT CABLE ASSY
2	E5071-61614	1	FLAT CABLE ASSY
3	E5071-61615	1	WIRE ASSY
4	E5052-61634	1	WIRE ASSY (6PIN)
5	E5052-61628	1	FLAT CABLE ASSY
6	E5070-61616	1	FLAT CABLE ASSY
7	E5071-61601	1	FLAT CABLE ASSY
8	E5052-61654	1	CABLE ASSY USB
9	E5052-61651	1	WIRE ASSY
10	E5052-61661	1	FLAT CABLE ASSY
11	E5052-61653	1	WIRE ASSY
12	E5052-61656	1	WIRE ASSY
13	E5052-61657	1	WIRE ASSY
14	E5052-61658	1	WIRE ASSY
15	E5052-61659	1	WIRE ASSY

Top View (Miscellaneous Parts)

Figure 5-4 Top View (Miscellaneous Parts)

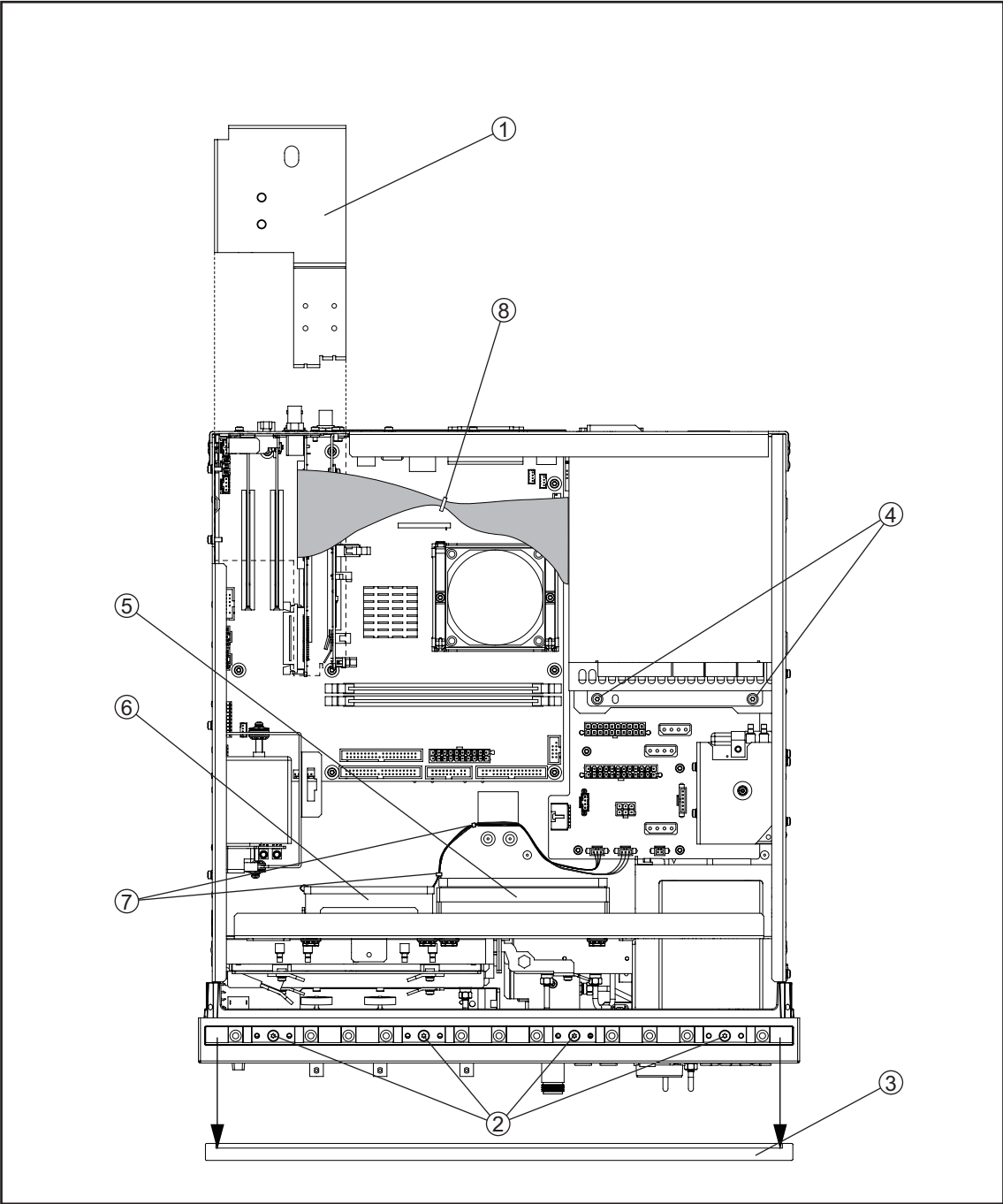

e5052bse1036

Table 5-3 Top View (Miscellaneous Parts)

Ref. Desig.	Agilent Part Number	Qty.	Description
1	E5052-01264	1	ANGLE
2	0515-1382	4	SCREW-MACH M3.5 x L6 FL T15
3	5041-9176	1	TRIM STRIP
4	0515-2113	2	SCREW-MACH M4.0 x L8 PN T20
5	E5052-01265	1	BRACKET FAN L
6	E5052-01266	1	BRACKET FAN M
7	1400-0493	2	CABLE TIE
8	1400-0493	1	CABLE TIE

Top View (Under Power Supply)

Figure 5-5 Top View (Under Power Supply)

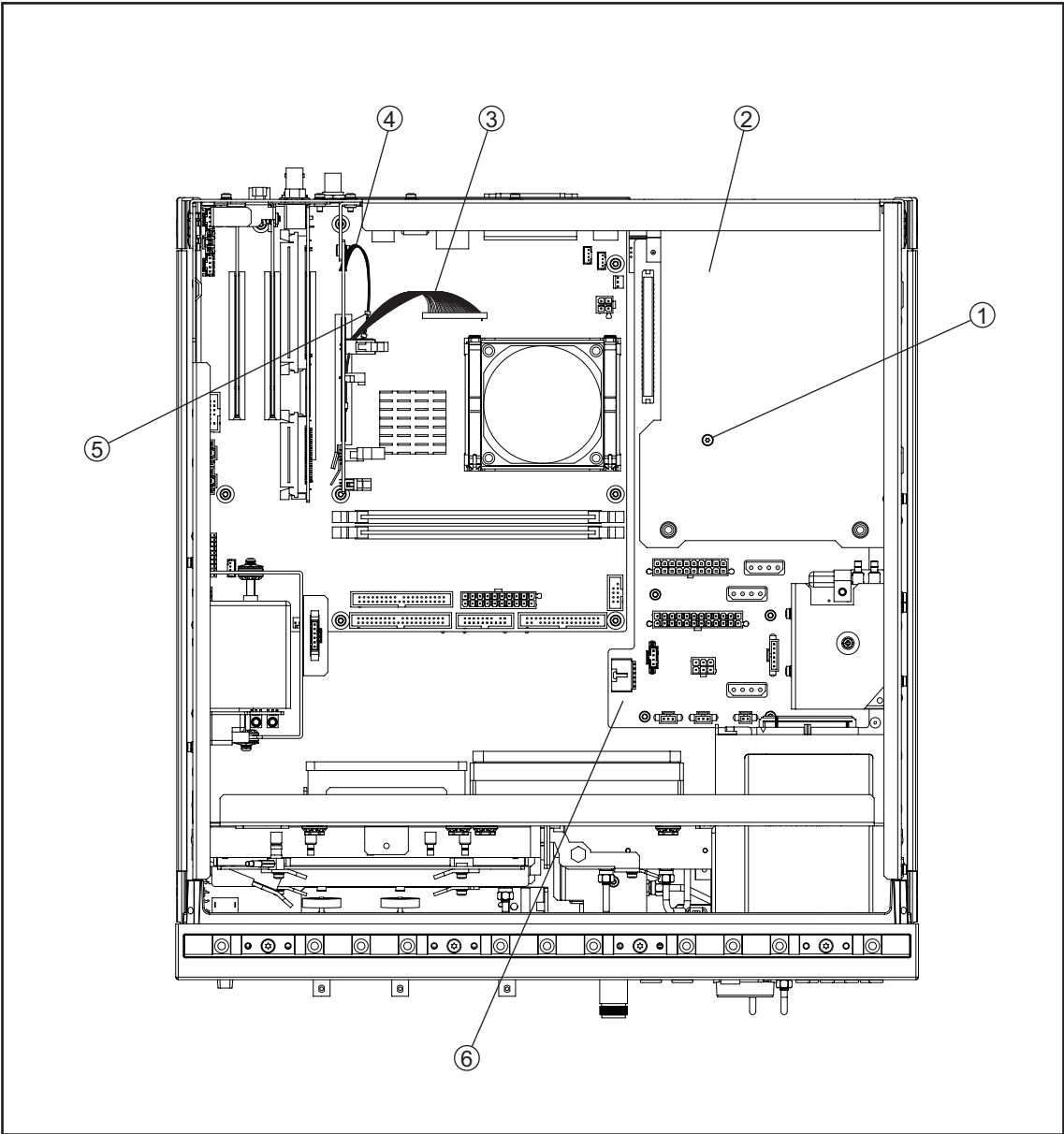

e5052bse1037

Table 5-4 Top View (Under Power Supply)

Ref. Desig.	Agilent Part Number	Qty.	Description
1	0515-2032	1	SCREW-MACH M3.0 x L8 FL T10
2	E5052-01262	1	ANGLE PS
3	E5071-61617	1	FLAT CABLE ASSY
4	E5071-61606	1	WIRE ASSY
5	5041-9174	1	TRIM-FR FR SIDE
	1400-3360	1	CLAMP CABLE 21MM WD
6	E5052-66522	1	A22 POWER DISTRIBUTION PCA

Top View (Motherboard and Other Parts)

Figure 5-6 Top View (Motherboard and Other Parts)

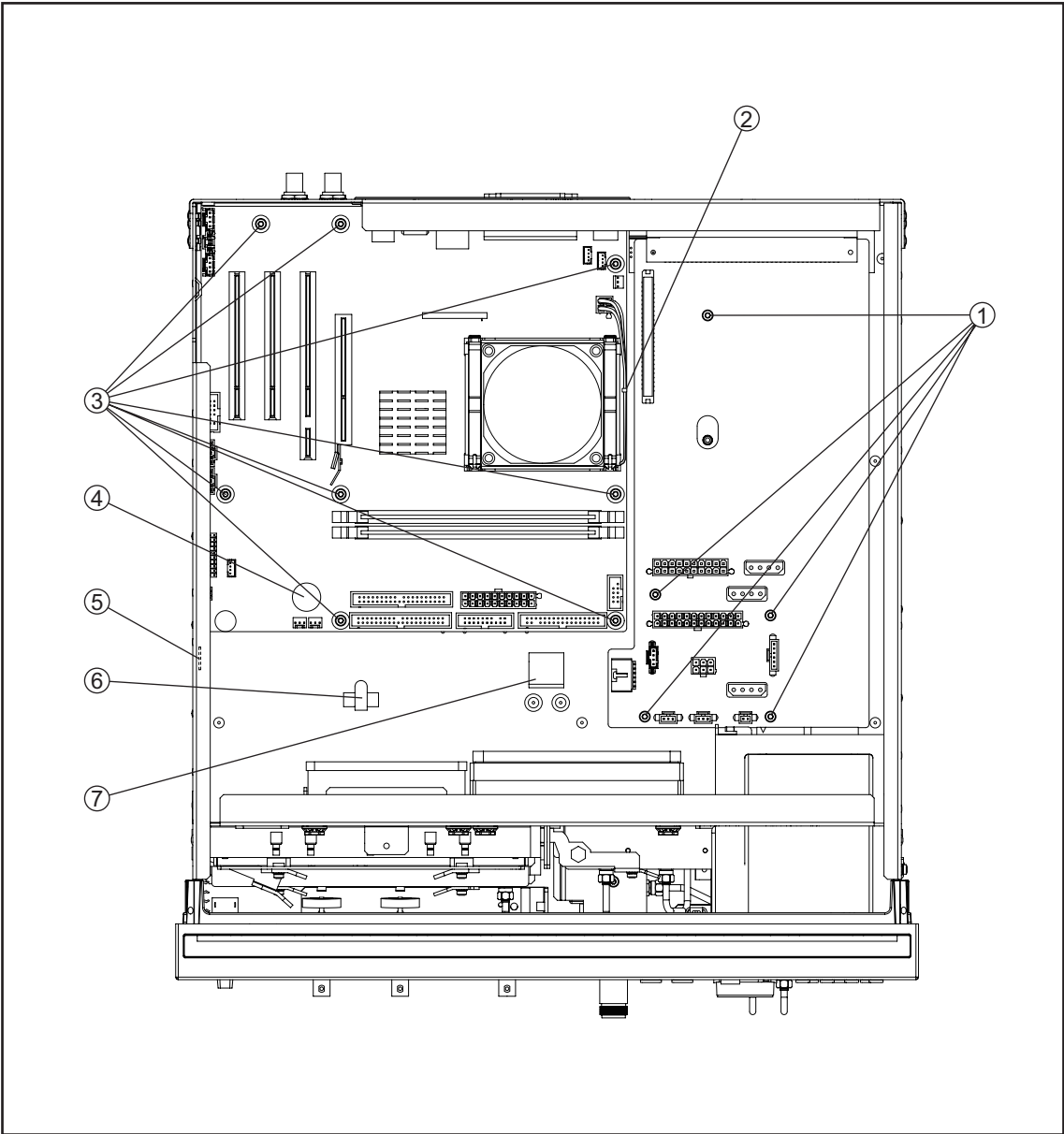

e5052bse1038

Table 5-5 Top View (Motherboard and Other Parts)

Ref. Desig.	Agilent Part Number	Qty.	Description
1	0515-0430	5	SCREW-MACH M3.0 x L6 PN T10
2	1400-0249	1	CABLE TIE
3	0515-0430	8	SCREW-MACH M3.0 x L6 PN T10
4	1420-0356	1	BATTERY LITHIUM (CR2032), 3V,.22A-HR
5	1400-1334	1	CLAMP-CABLE STL
6	1400-1334	1	CLAMP-CABLE STL
7	1400-0611	1	CLAMP-FL-CA

Bottom View

Figure 5-7 Bottom View

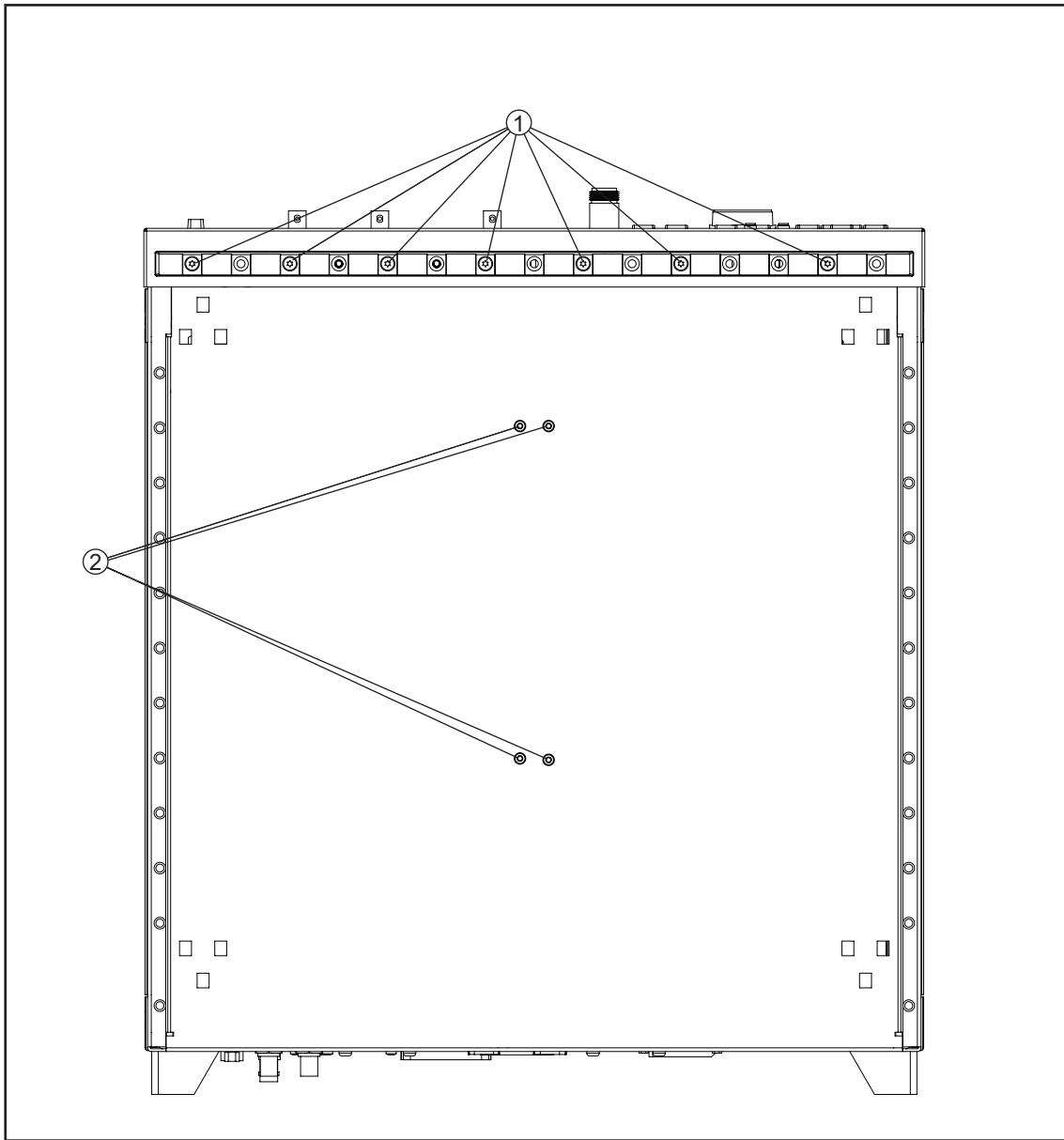

e5052bse1039

Table 5-6 Bottom View

Ref. Desig.	Agilent Part Number	Qty.	Description
1	0515-1382	7	SCREW-MACH M3.5 x L6 FL T15
2	0515-0430	4	SCREW-MACH M3.0 x L6 PN T10

Front View (Analog Boards)

Figure 5-8 Front View (Analog Boards)

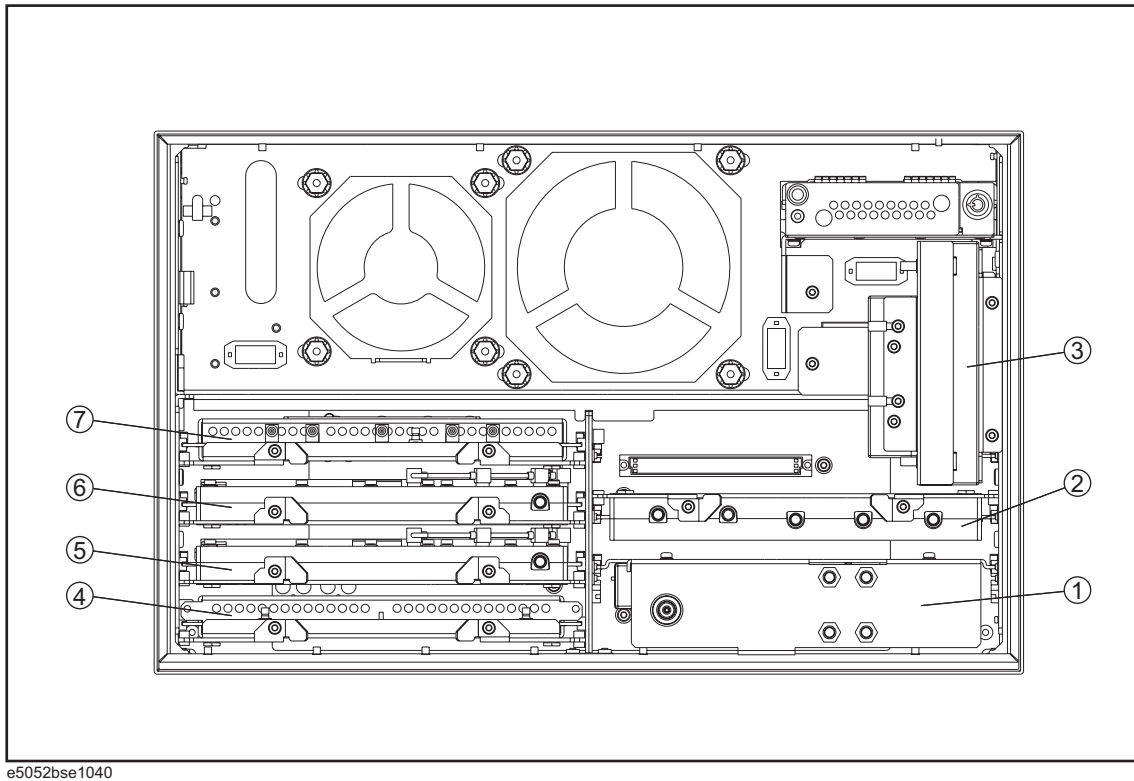

e5052bse1040

Table 5-7 Front View (Analog Boards)

Ref. Desig.	Agilent Part Number	Qty.	Description
1	E5052-62111	1	A1 FREQ/POWER DETECTOR MODULE
	E5052-69111	1	RSTRD E5052-62111 FREQ/POWER
2	See Table 5-26	1	A6 PHASE DETECTOR BOARD ASSY
3	See Table 5-21	1	A57 DC BLOCK ASSY
4	E5052-62022	1	A2 DC SOURCE BOARD ASSY
	E5052-69022	1	RSTRD E5052-62022 DC SOURCE
5	See Table 5-25	1	A5 LOCAL SYNTHESIZE MODULE
6	See Table 5-25	1	A4 LOCAL SYNTHESIZE MODULE
7	E5052-62013	1	A3 ADC/DSP BOARD ASSY
	E5052-69013	1	RSTRD E5052-62013 ADC/DSP

Front View (Cables)

Figure 5-9 Front View (Cables)

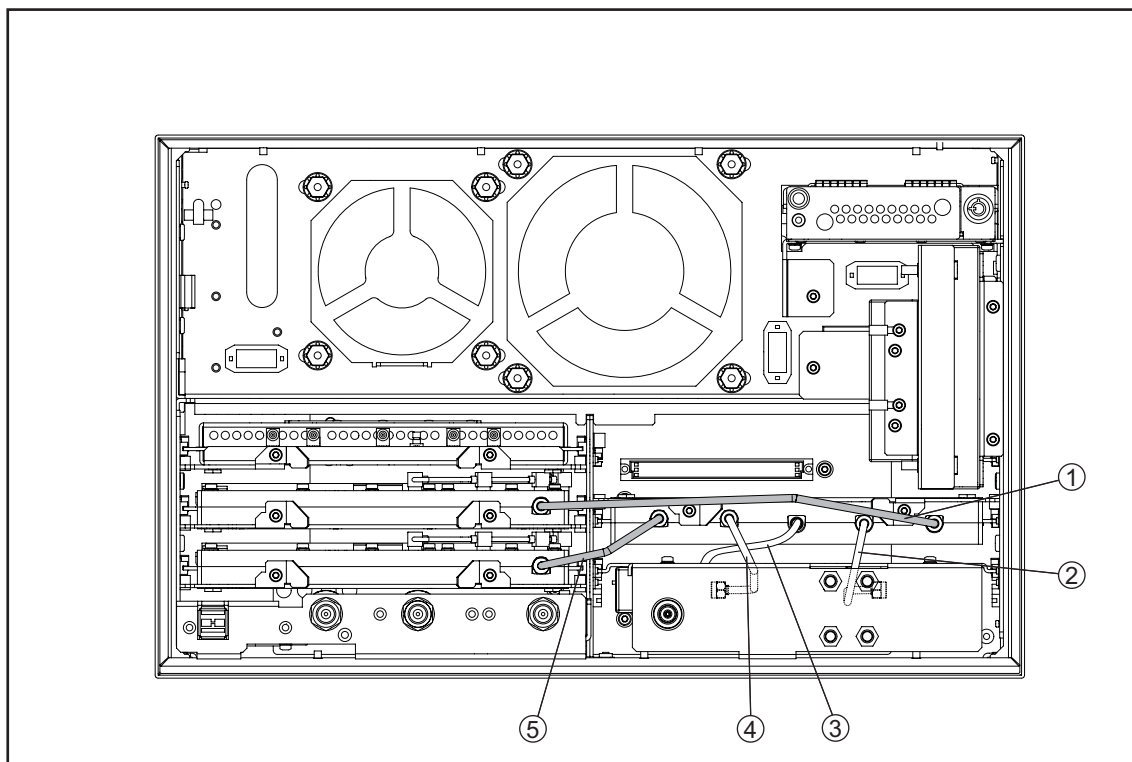

e5052bse1041

Table 5-8 Front View (Cables)

Ref. Desig.	Agilent Part Number	Qty.	Description
1	E5052-61681	1	RF CABLE ASSY SRGD
2	E5052-61619	1	RF CABLE ASSY SRGD
3	E5052-61678	1	RF CABLE ASSY SRGD
4	E5052-61620	1	RF CABLE ASSY SRGD
5	E5052-61682	1	RF CABLE ASSY SRGD

Front View (Miscellaneous)

Figure 5-10 Front View (Miscellaneous)

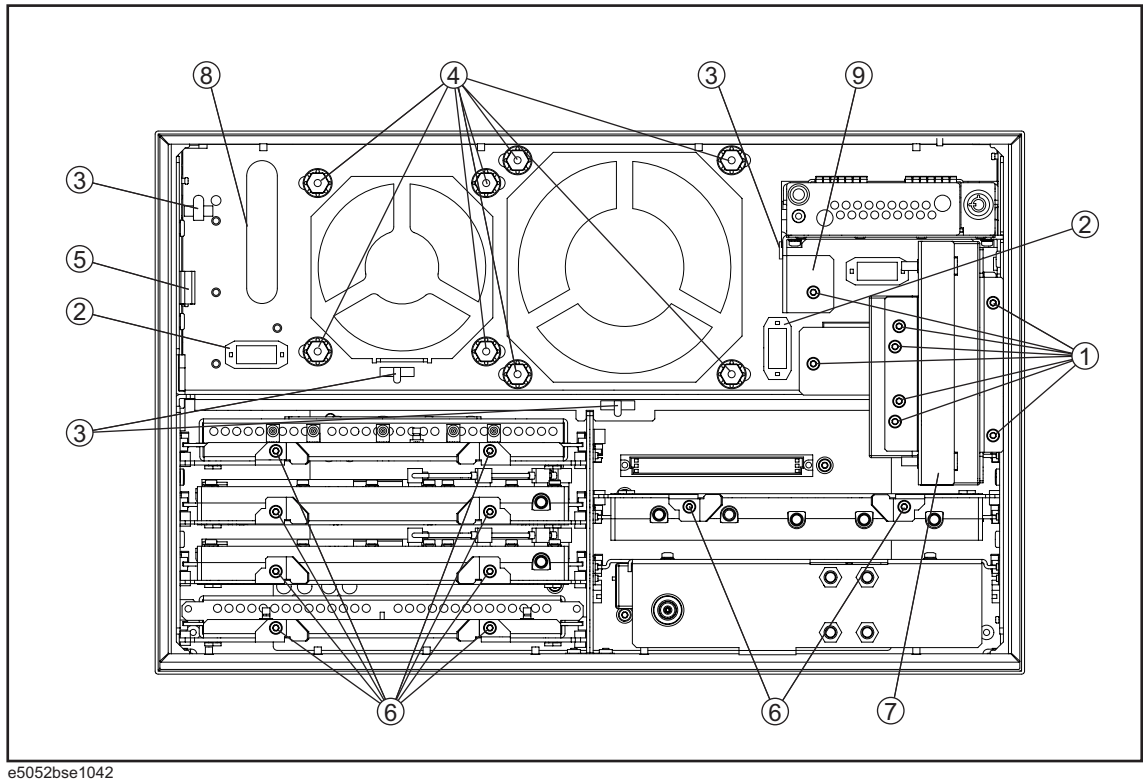
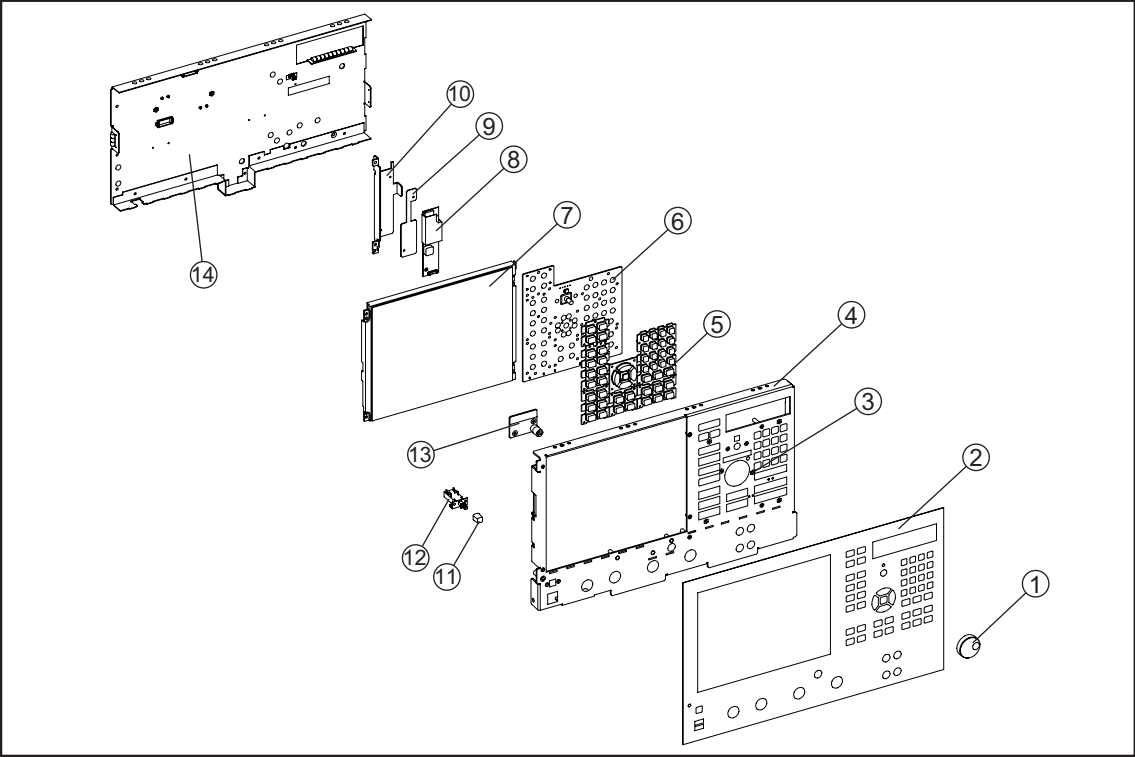

Table 5-9 Front View (Miscellaneous)

Ref. Desig.	Agilent Part Number	Qty.	Description
1	0515-0430	8	SCREW-MACH M3.0 x L6 PN T10
2	1400-3156	2	CLAMP-CABLE NYLON
3	1400-1391	4	CLAMP-CABLE STL
4	E5052-24009	8	HEX BOLT
	0400-0356	8	GROMMET-RND SERR
5	1400-3337	2	CLAMP-CABLE
6	0515-0430	10	SCREW-MACH M3.0 x L6 PN T10
7	E5052-00659	1	CASE SHIELD
8	0400-0254	1	GROMMET-CHANNEL
9	E5052-01261	1	BRACKET HDD

Front Panel

Figure 5-11 Front Panel



e5052bse1043

Table 5-10 Front Panel

Ref. Desig.	Agilent Part Number	Qty.	Description
1	5182-7594	1	KNOB
2	E5052-00211	1	PANEL FRONT
3	04191-08000	1	SPRING
4	E5052-00212	1	PANEL SUB
5	E5052-25111	1	KEYPAD RUBBER
6	E5070-66552	1	FRONT PANEL KEYBOARD
7	E5070-60112	1	LCD-TPANEL ASSY
8	See Table 5-32	1	A52 INVERTER LS700
9	See Table 5-32	1	A52 INVERTER LS700
10	See Table 5-32	1	A52 INVERTER LS700
11	0371-3953	1	KEY CAP
12	See Table 5-30	1	STANDBY SWITCH
13	See Table 5-30	1	PCA PROBE POWER
14	E5052-00602	1	COVER SHIELD

Replaceable Parts
 Replaceable Parts List

Rear View

Figure 5-12 Rear View

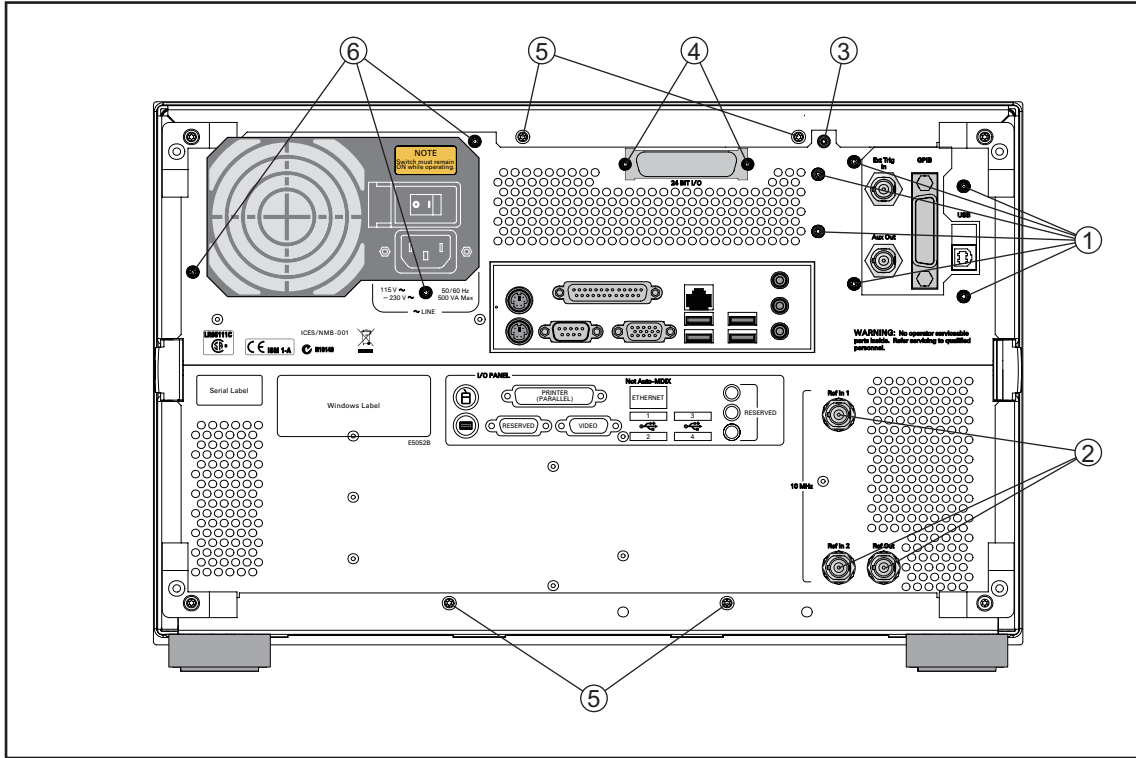

e5052bse1044

Table 5-11 Rear View

Ref. Desig.	Agilent Part Number	Qty.	Description
1	0515-0372	6	SCREW-MACH M3.0 x L8 PN T10
2	2950-0035	3	NUT-HEX-DBL-CHAM
	2190-0102	3	WSHR-LK INTL T
3	0515-0372	1	SCREW-MACH M3.0 x L8 PN T10
4	0515-0372	2	SCREW-MACH M3.0 x L8 PN T10
5	0515-1402	4	SCREW-MACH M3.5 x L8 PN T15
6	0515-2032	3	SCREW-MACH M3.0 x L8 FL T10

Cover Assembly

Figure 5-13

Cover Assembly

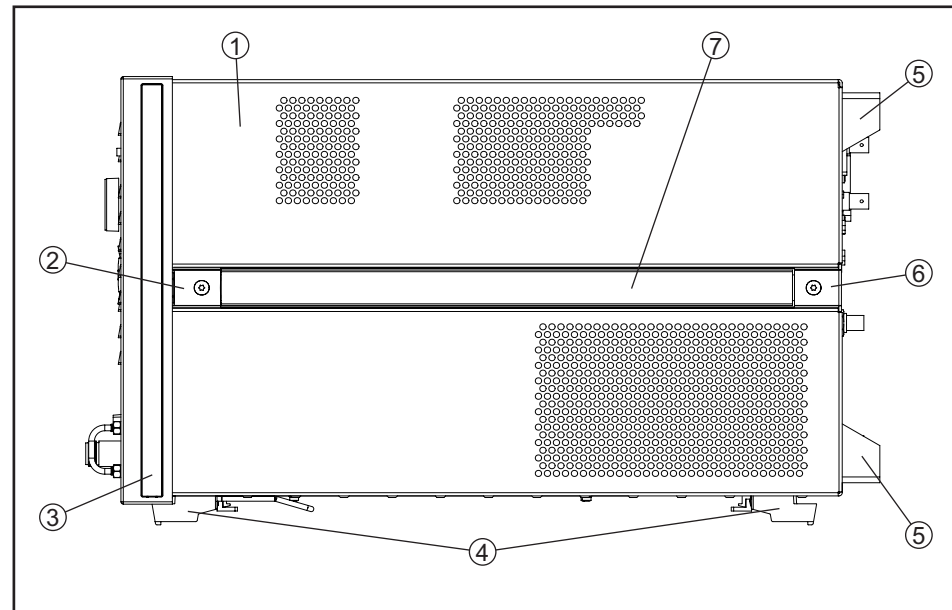

e5052bse1045

Table 5-12

Cover Assembly

Ref. Desig.	Agilent Part Number	Qty.	Description
1	E5052-60022	1	COVER ASSY
2	5041-9186	2	STRAP HANDLE FRT
	0515-2049	2	SCREW-MACH M5.0 x L16 FL T20
3	5041-9174	2	TRIM-FR FR SIDE
4	5041-9167	4	FOOT FL
	1460-1345	2	WIREFORM
	5021-2840	4	KEY LOCK
5	E5100-40002	4	STANDOFF
	0515-1402	4	SCREW-MACH M3.5 x L8 PN T15
6	5041-9187	2	STRAP HANDLE REAR
	0515-2049	2	SCREW-MACH M5.0 x L16 FL T20
7	08720-00081	2	STRAP HANDLE

Left Side View

Figure 5-14

Left Side View

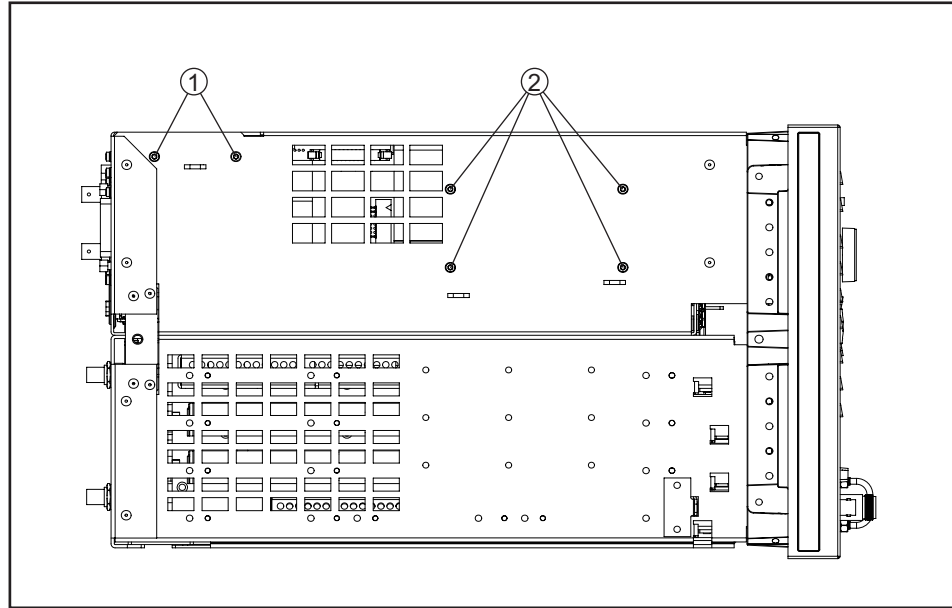

e5052bse1046

Table 5-13

Left Side View

Ref. Desig.	Agilent Part Number	Qty.	Description
1	0515-0372	2	SCREW-MACH M3.0 x L8 PN T10
2	0515-0372	4	SCREW-MACH M3.0 x L8 PN T10

Right Side View

Figure 5-15

Right Side View

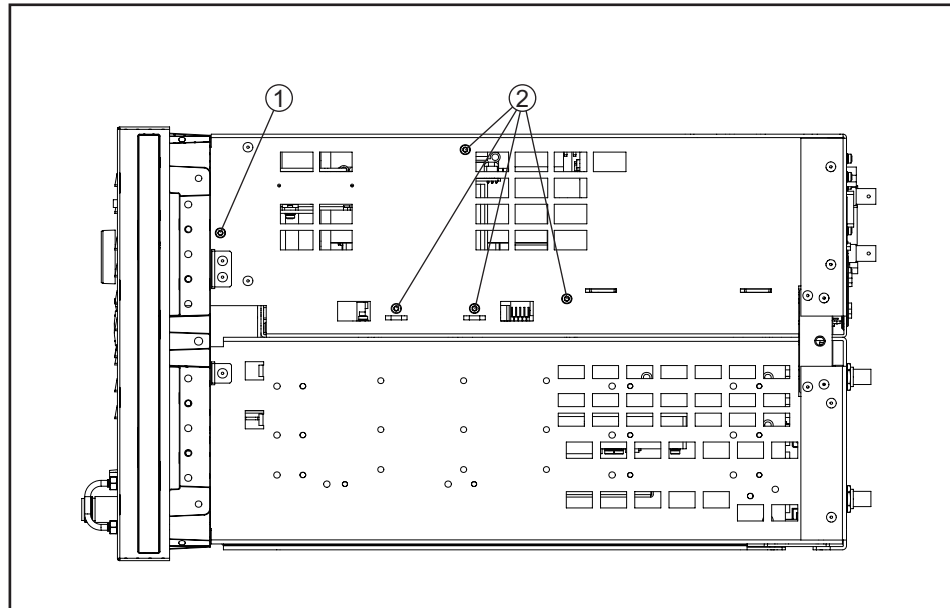

e5052bse1047

Table 5-14

Right Side View

Ref. Desig.	Agilent Part Number	Qty.	Description
1	0515-0430	1	SCREW-MACH M3.0 x L6 PN T10
2	0515-0372	4	SCREW-MACH M3.0 x L8 PN T10

Removable Hard Disk Drive Assembly

Figure 5-16

Removable Hard Disk Drive Assembly

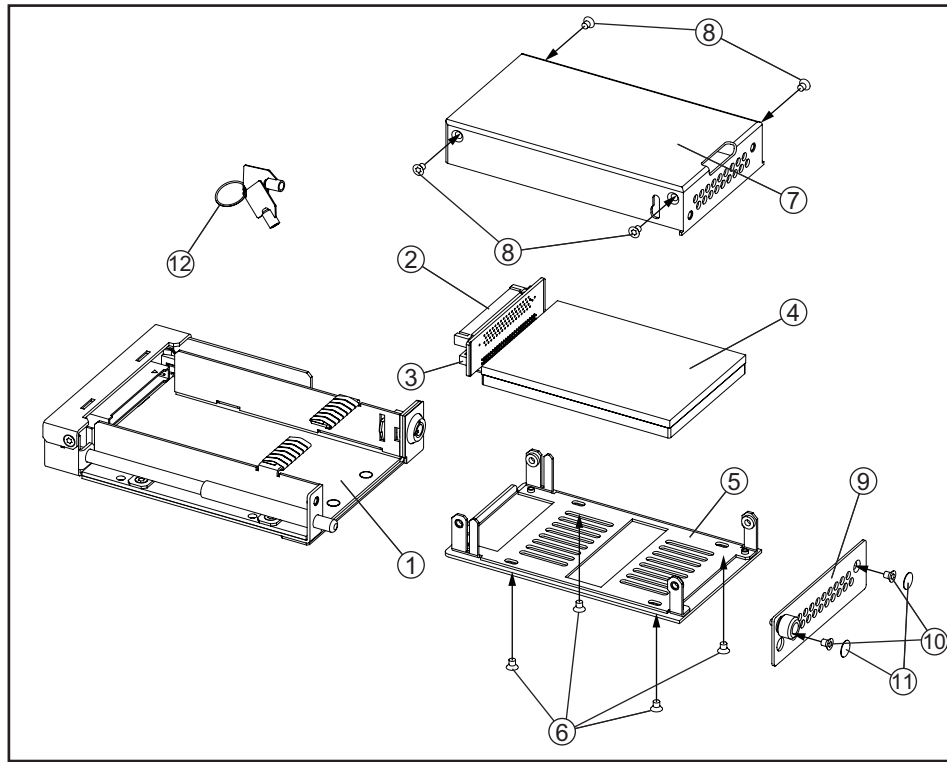

e5052bse1104

Table 5-15 Removable Hard Disk Drive Assembly

Ref. Desig.	Agilent Part Number	Qty.	Description
1	E5052-60101	1	REMOVABLE HDD 2.5INCH RECEIVING FRAME ASSY
2	E5070-66538	1	CONNECTOR BD PCA
3	E5070-61668	1	FLAT CBL ASSY
4	E5052-82201	1	HDD INSTALLED
5	E5070-00650	1	PLATE BOTTOM
6	0515-2146	4	SCREW-MACH M3.0 x L4 FL T10
7	E5070-04006	2	COVER
8	0515-1946	4	SCREW-MACH M3.0 x L6 FL T10
9	E5070-00655	1	PLATE FRONT
10	0515-2146	2	SCREW-MACH M3.0 x L6 FL T10
11	E5070-87301	2	LABEL
12	1390-1375	1	HDD KEYS

PCI DSP Card and GPIB Card Assembly

Figure 5-17

PCI DSP Card and GPIB Card Assembly

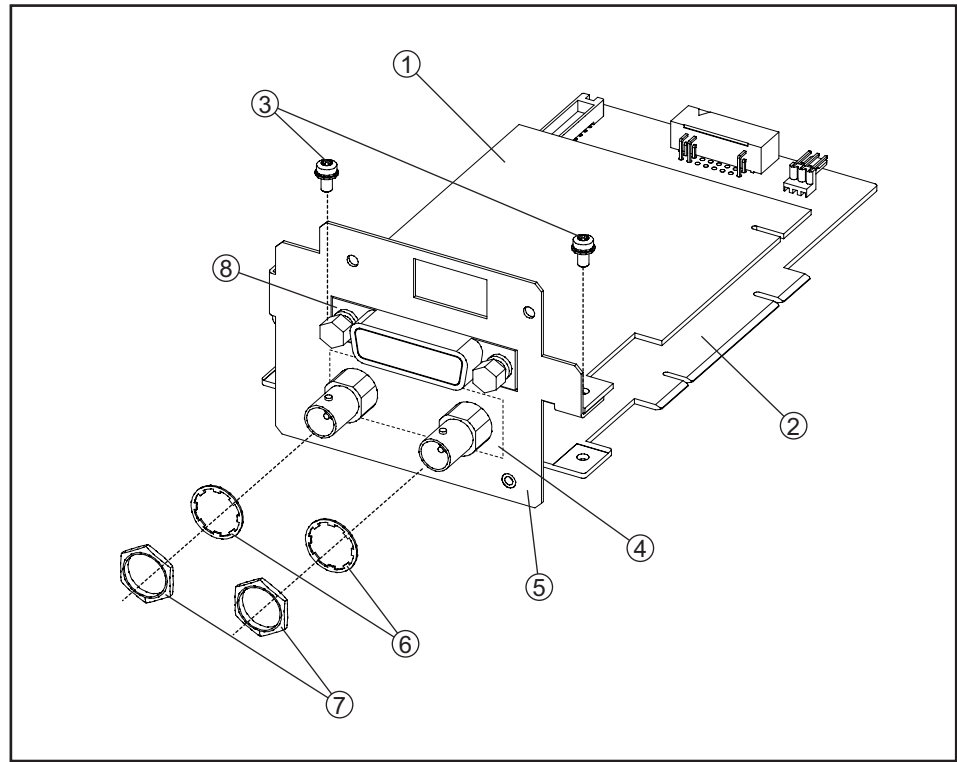

e5052bse1048

Table 5-16

PCI DSP Card and GPIB Card Assembly

Ref. Desig.	Agilent Part Number	Qty.	Description
1	82350-66512	1	PCI GPIB CARD
2	E5070-66551	1	PCI DSP CARD
3	0515-0430	2	SCREW-MACH M3.0 x L6 PN T10
4	E5052-07003	1	SHIM
5	E5052-01298	1	ANGLE PCI W/GPIB
6	2190-0054	2	WSHR-LK INTL T
7	2950-0054	2	NUT-HEX-DBL-CHAM
8	1253-6142	1	SHIELD

USB Card Assembly

Figure 5-18

USB Card Assembly

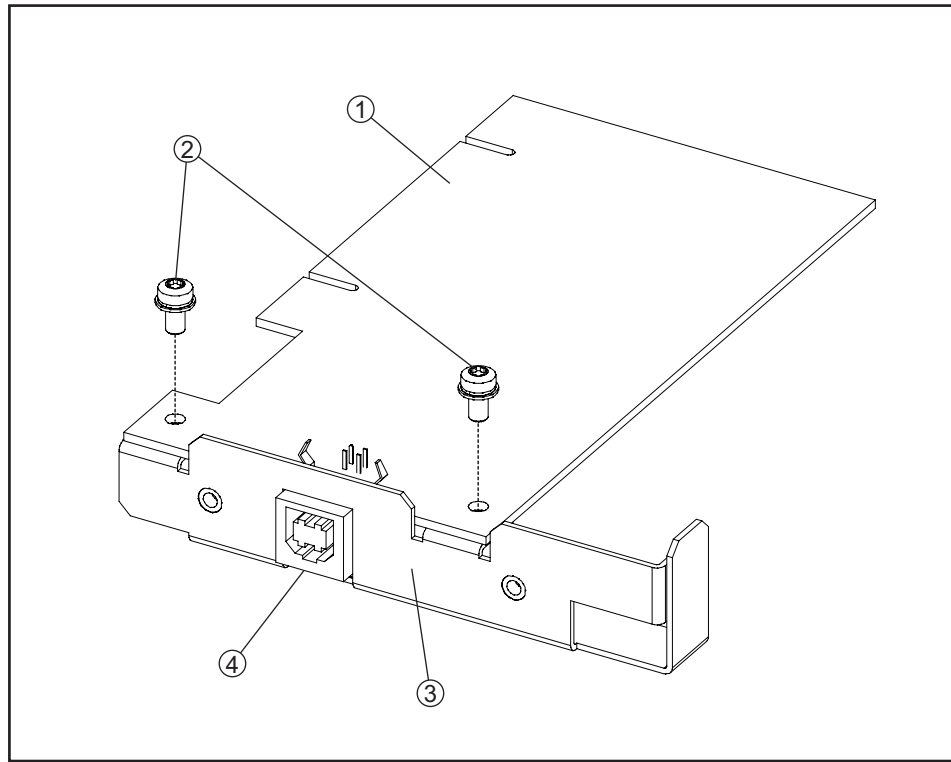

e5052bse1049

Table 5-17

USB Card Assembly

Ref. Desig.	Agilent Part Number	Qty.	Description
1	0960-2357	1	USB ADAPTER CARD
2	0515-0430	2	SCREW-MACH M3.0 x L6 PN T10
3	E5071-01218	1	BRACKET USB
4	0363-0170	1	GASKET 2-UNITS

PCA Digital Board Assembly

Figure 5-19 PCA Digital Board Assembly

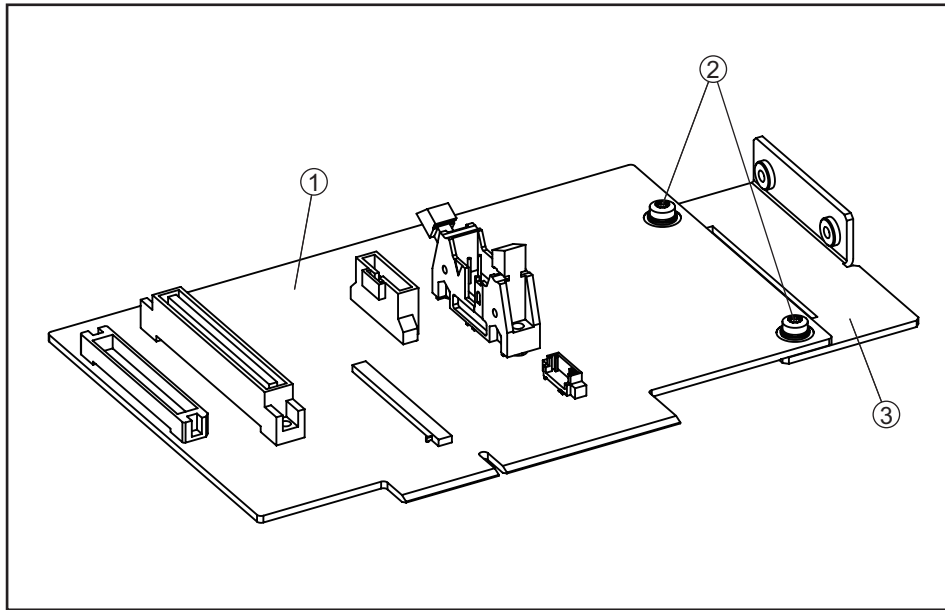

e5071cse1088

Table 5-18 PCA Digital Board Assembly

Ref. Desig.	Agilent Part Number	Qty.	Description
1	E5070-66553	1	PCI DIGITAL BRIDGE
2	0515-0430	2	SCREW-MACH M3.0 x L6 PN T10
3	E5071-01210	1	STAY

Oven Ch1 Assembly

Figure 5-20 Oven Ch1 Assembly

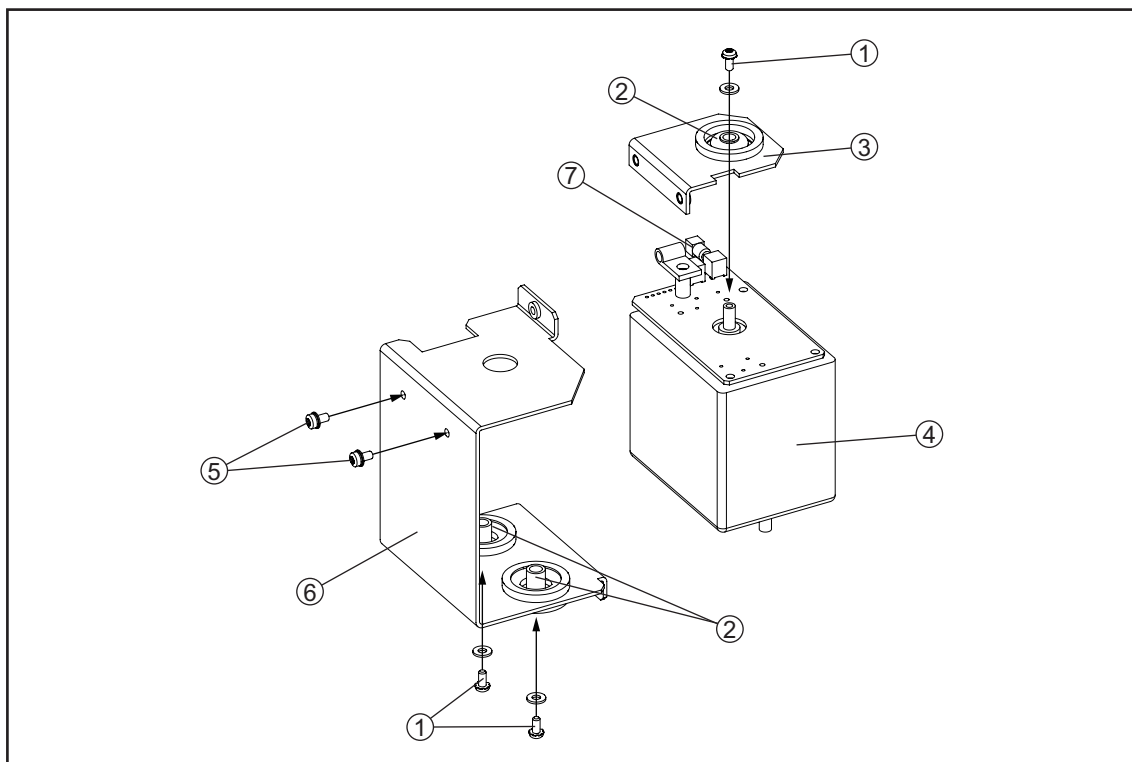

e5052bse1083

Table 5-19 Oven Ch1 Assembly

Ref. Desig.	Agilent Part Number	Qty.	Description
1	2200-0239	3	SCREW-MACH 4-40 0.25-IN-LG PN T10
	3050-0105	3	WASHER-FL
2	1520-0205	3	GROMMET
3	E8251-00041	1	L BRACKET
4	E5052-81001	1	CRYSTAL OSC OCXO
5	0515-0372	2	SCREW-MACH M3.0 x L8 PN T10
6	E8251-00040	1	C BRACKET
7	1250-3563	1	SHORT CAP

Oven Ch2 Assembly

Figure 5-21

Oven Ch2 Assembly

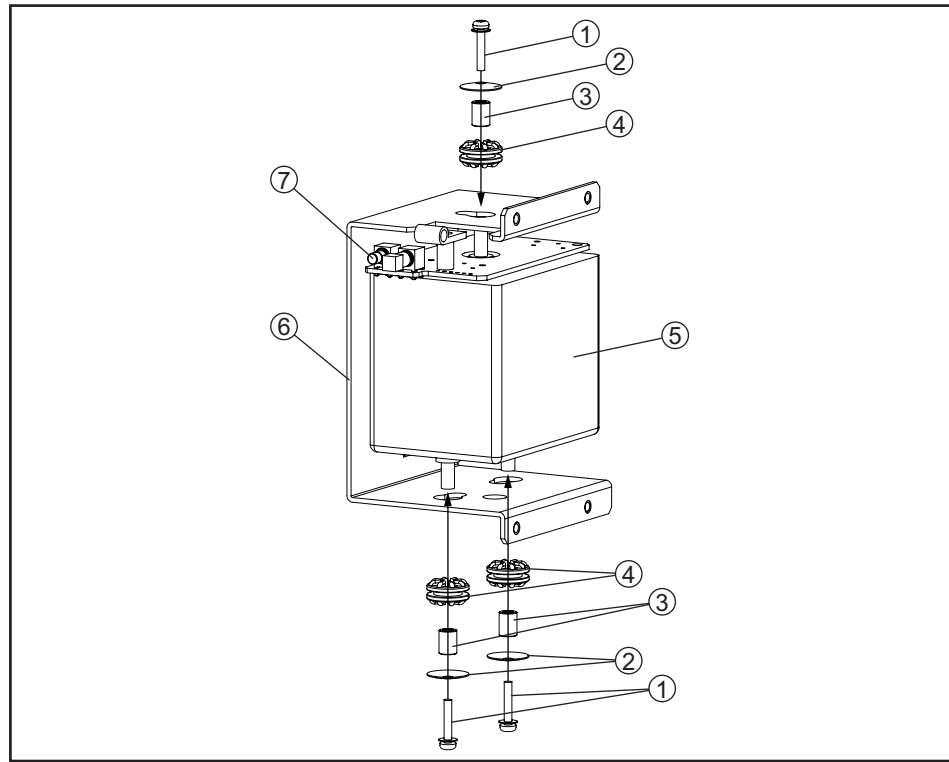

e5052bse1084

Table 5-20 Oven Ch2 Assembly

Ref. Desig.	Agilent Part Number	Qty.	Description
1	3030-1353	3	SCREW-MACH 4-40 0.625-IN-LG PN T10
2	3050-1628	3	WASHER-SPR
3	0380-1402	3	SPACER-RND 8MM-LG
4	0400-0356	3	GROMMET-RND
5	1813-2141	1	CRYSTAL OSC OCXO
6	E5052-01267	1	C-BRACKET
7	1250-3563	1	SHORT CAP

DC Block Unit Assembly

Figure 5-22 DC Block Unit Assembly

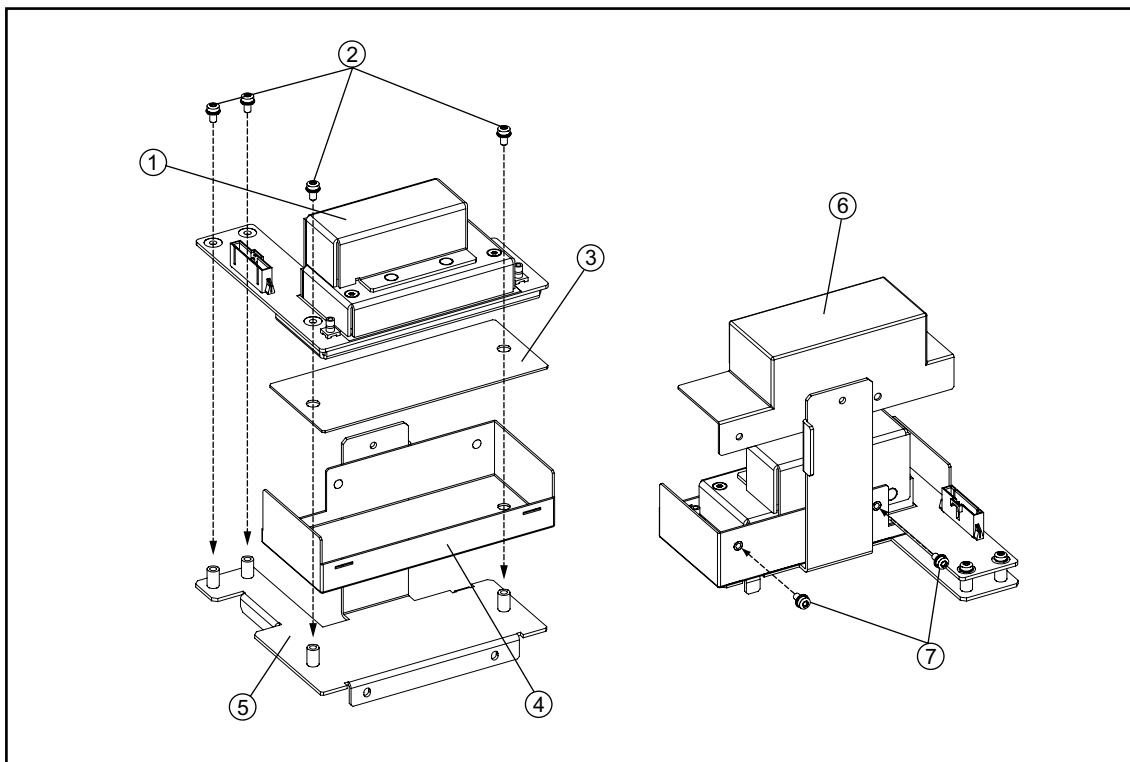

e5052bse1050

Table 5-21 DC Block Unit Assembly

Ref. Desig.	Agilent Part Number	Qty.	Description
1	E5052-61057	1	DC BLOCK
2	0515-0430	4	SCREW-MACH M3.0 x L6 PN T10
3	E5052-25005	1	INSULATOR
4	E5052-00657	1	CASE SHIELD
5	E5052-01238	1	BRACKET DC BLOCK
6	E5052-00658	1	CASE SHIELD
7	0515-0430	2	SCREW-MACH M3.0 x L6 PN T10

Analog Mother Board Assembly

Figure 5-23 Analog Mother Board Assembly

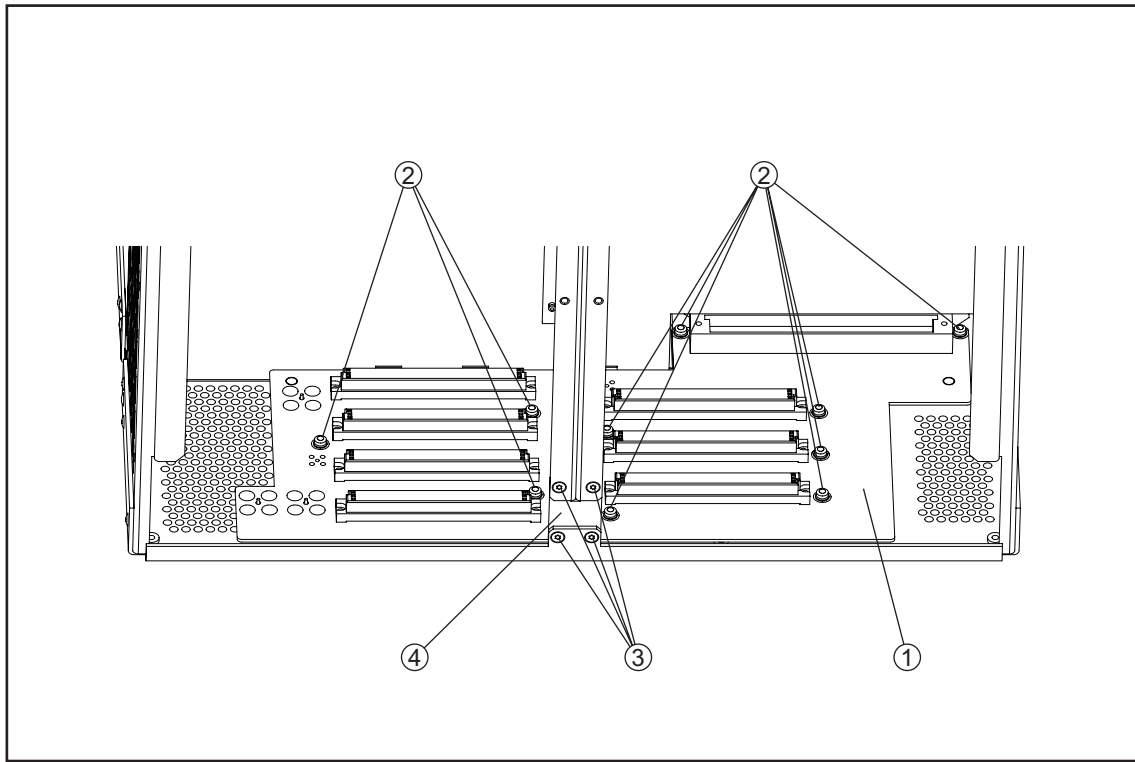

e5052bse1051

Table 5-22 Analog Mother Board Assembly

Ref. Desig.	Agilent Part Number	Qty.	Description
1	E5052-66550	1	ANALOG MOTHER PCA
2	0515-0372	10	SCREW-MACH M3.0 x L8 PN T10
3	0515-1946	4	SCREW-MACH M3.0 x L6 FL T10
4	E5052-00609	1	PLATE

Freq/Power Detector Module Attachment Assembly

Figure 5-24

Freq/Power Detector Module Attachment Assembly

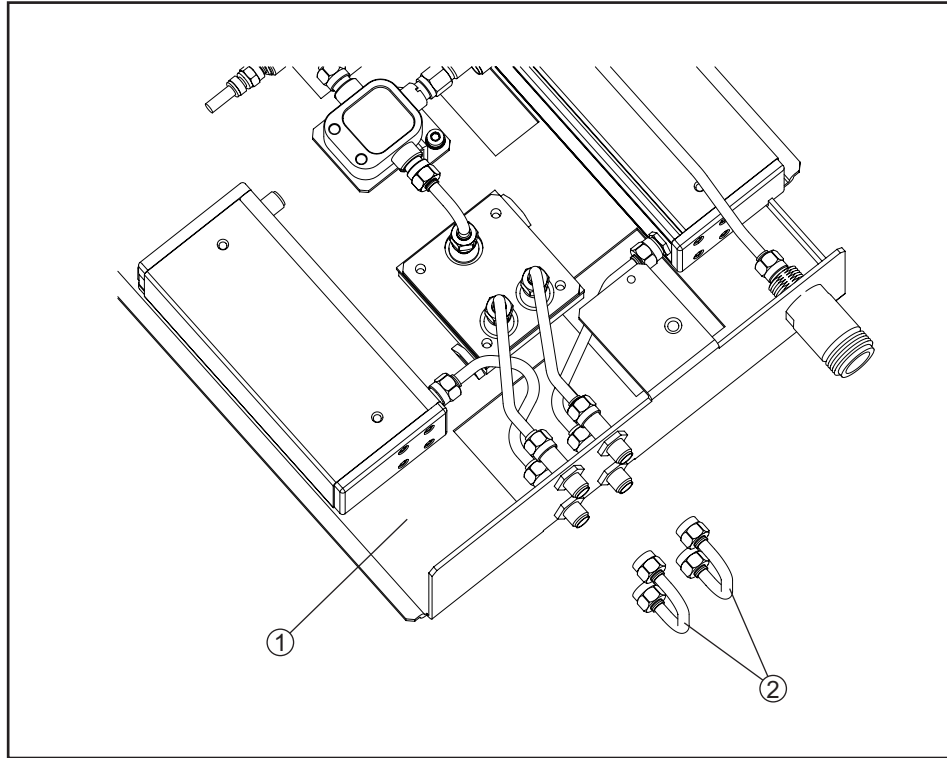

e5052bse1052

Table 5-23

Freq/Power Detector Module Attachment Assembly

Ref. Desig.	Agilent Part Number	Qty.	Description
1	E5052-62111	1	A1 FREQ/POWER DETECTOR MODULE
2	E5052-61611	2	RF CBL ASSY SRGD

DC Source Board Attachment Assembly

Figure 5-25

DC Source Board Attachment Assembly

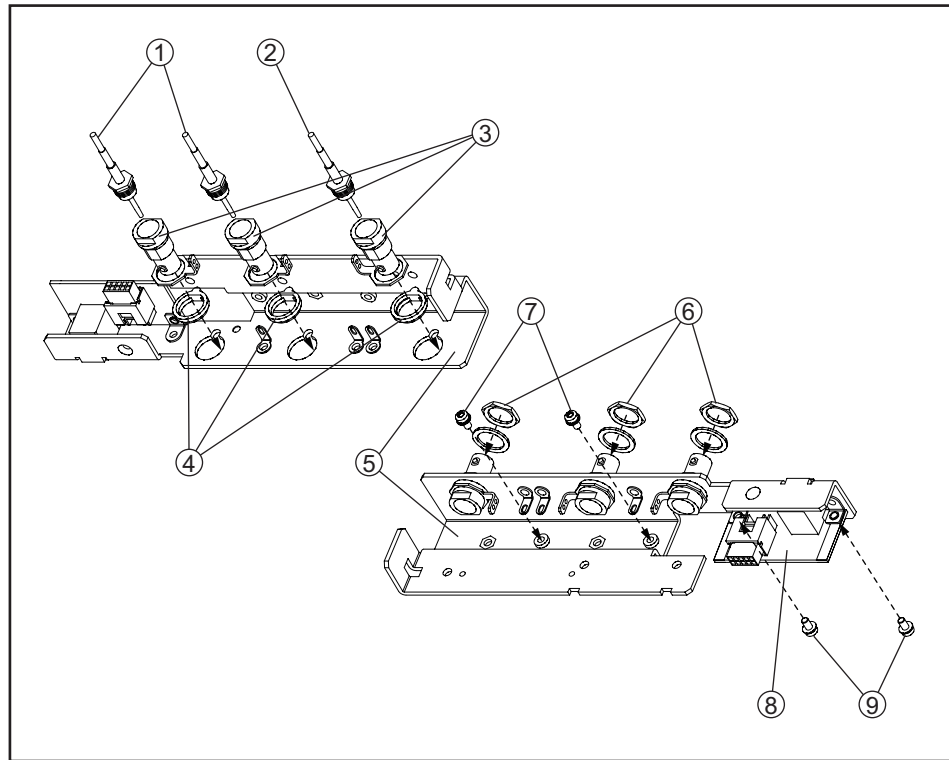

e5052bse1053

Table 5-24

DC Source Board Attachment Assembly

Ref. Desig.	Agilent Part Number	Qty.	Description
1	E5052-61642	2	CABEL ASSY
2	E5052-61692	1	RF CABLE ASSY
3	1250-0252	3	CONNECTOR BODY-RF SERIES STRAIGHT BNC
4	04284-01211	3	PLATE
	5040-3325	3	INSULATOR BNC
5	E5052-01263	3	BRACKET BNC
6	2950-0035	3	NUT-HEX-DBL-CHAM
	5040-3324	3	INSULATOR BNC
7	0515-0372	2	SCREW-MACH M3.0 x L8 PN T10
8	E5052-66555	1	FRONT USB PCA
9	0515-0430	2	SCREW-MACH M3.0 x L6 PN T10

Local Synthesize Module Assembly

Figure 5-26

Local Synthesize Module Assembly

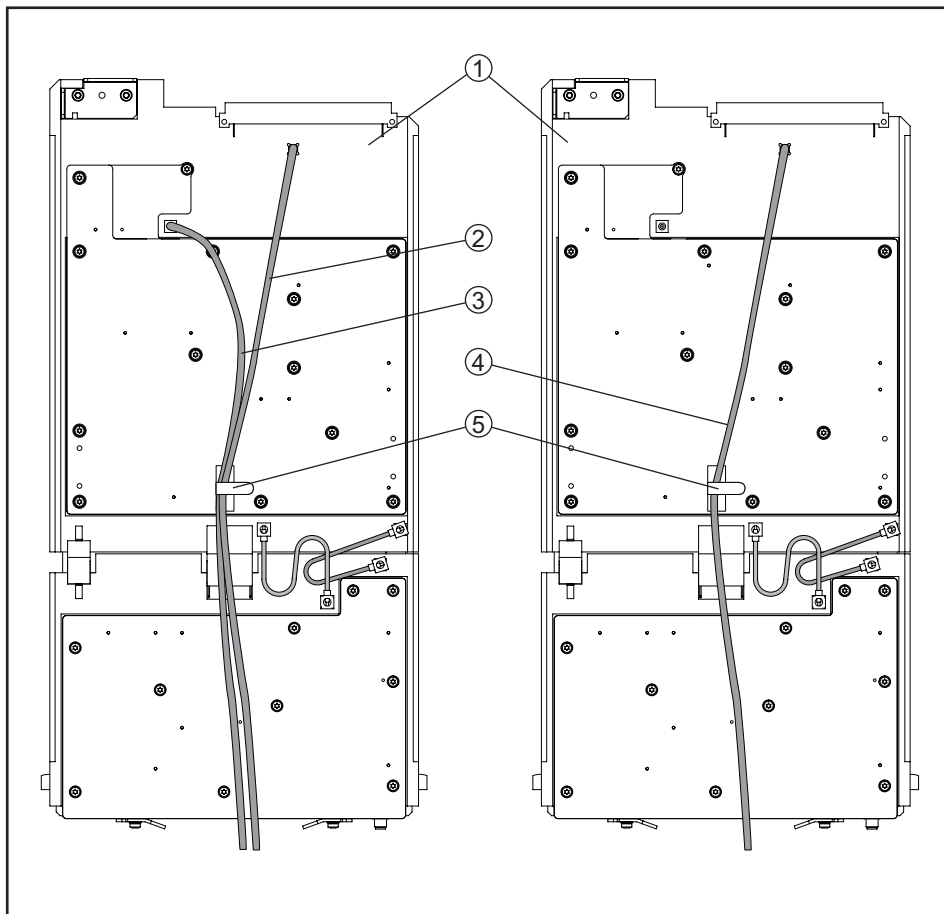

e5052bse1054

Table 5-25

Local Synthesize Module Assembly

Ref. Desig.	Agilent Part Number	Qty.	Description
1	E5052-62034	2	A4/A5 LOCAL SYNTHESIZE MODULE ASSY
	E5052-69034	2	RSTRD E5052-62034 SYNTHESIZE
2	E5052-61675	1	RF CABLE ASSY
3	5188-1325	1	RF CABLE ASSY
4	E5052-61673	1	RF CABLE ASSY
5	1400-1334	2	CLAMP-CABLE

Phase Detector Board Assembly

Figure 5-27

Phase Detector Board Assembly

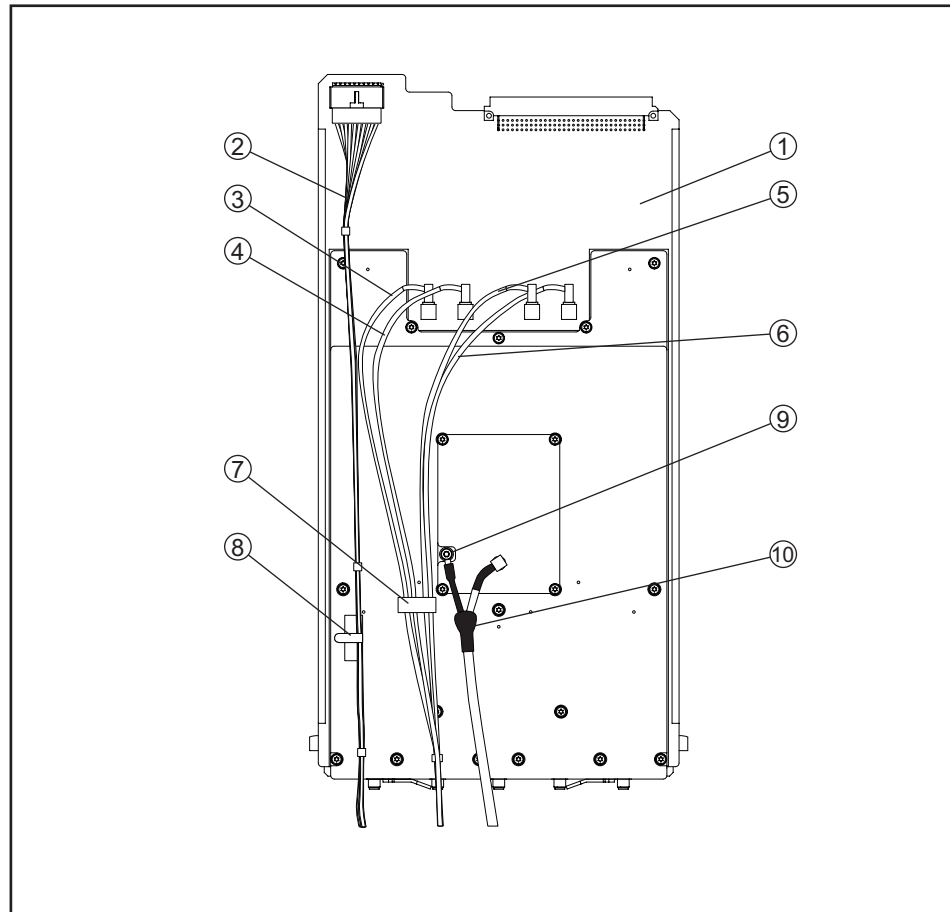

e5052bse1055

Table 5-26

Phase Detector Board Assembly

Ref. Desig.	Agilent Part Number	Qty.	Description
1	E5052-62026	1	A6 PAHSE DETECTOR BOARD ASSY
	E5052-69026	1	RSTRD E5052-62026 PHASE DET
2	E5052-61660	1	WIRE ASSY
3	5188-1269	1	RF CABLE ASSY
4	5188-1278	1	RF CABLE ASSY
5	5188-1324	1	RF CABLE ASSY
6	5188-1287	1	RF CABLE ASSY
7	1400-3361	1	CLAMP-CABLE 16MM
8	1400-1334	1	CLAMP-CABLE STL

Replaceable Parts
Replaceable Parts List

Table 5-26 **Phase Detector Board Assembly**

Ref. Desig.	Agilent Part Number	Qty.	Description
9	0515-0430	1	SCREW-MACH M3.0 x L6 PN T10
10	E5052-61694	1	RF CABLE ASSY

Chassis Assembly

Figure 5-28 Chassis Assembly

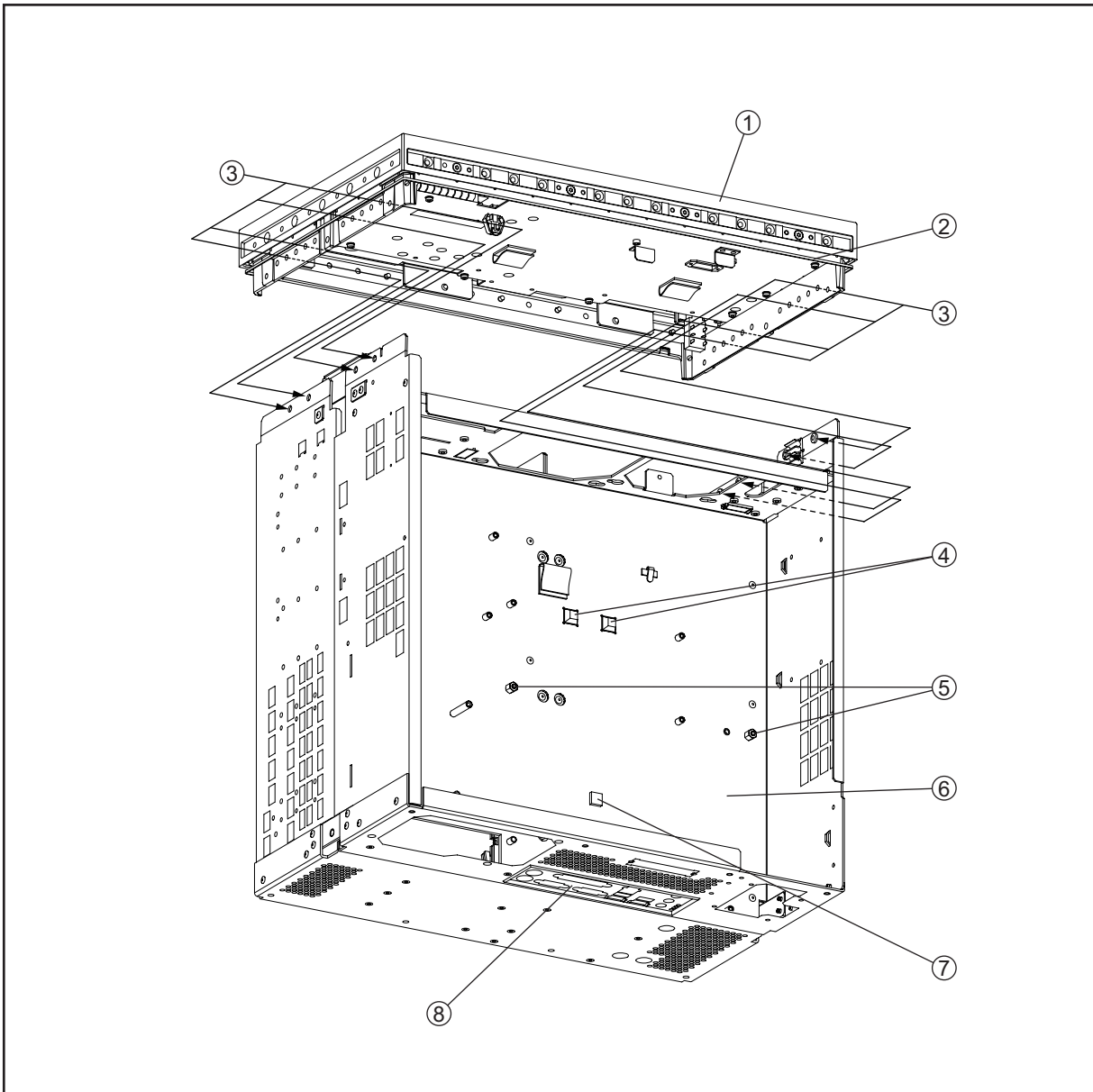

e5052bse1056

Table 5-27 Chassis Assembly

Ref. Desig.	Agilent Part Number	Qty.	Description
1	5022-7129	1	FRONT FRAME
2	8160-0641	1	RFI BRAID STRIP 1.35 M
3	0515-2113	8	SCREW-MACH M4.0 x L8 PN T15

Replaceable Parts
Replaceable Parts List

Table 5-27 **Chassis Assembly**

Ref. Desig.	Agilent Part Number	Qty.	Description
4	0403-0285	2	BUMPER
5	E5071-24007	2	SPACER
6	E5052-60021	1	CHASSIS ASSY
7	1520-0685	1	DAMPER
8	8160-1677	1	I/O SHIELD

Front Cover Assembly

Figure 5-29 Front Cover Assembly

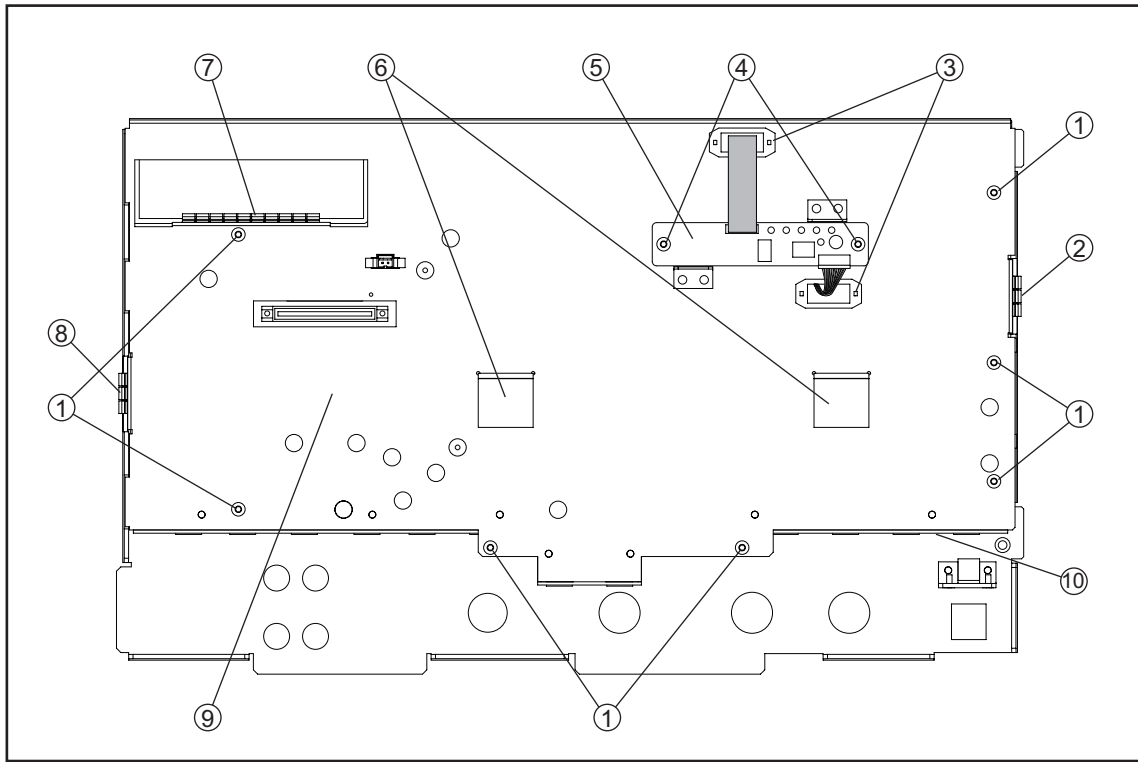

e5052bse1057

Table 5-28 Front Cover Assembly

Ref. Desig.	Agilent Part Number	Qty.	Description
1	0515-0430	7	SCREW-MACH M3.0 x L6 PN T10
2	0363-0170	1	GASKET 3-UNITS
3	1400-3156	2	CLAMP-CABLE NYLON 6/6
4	0515-0430	2	SCREW-MACH M3.0 x L6 PN T10
5	5183-5184	1	CNTR TOUCH PANEL
6	1400-0611	2	CLAMP-FL-CA
7	0363-0170	1	GASKET 10-UNITS
8	0363-0170	1	GASKET 3-UNITS
9	E5052-00602	1	COVER SHIELD
10	1400-1048	1	SADDLE-EDGE

Front Assembly (LCD)

Figure 5-30 Front Assembly (LCD)

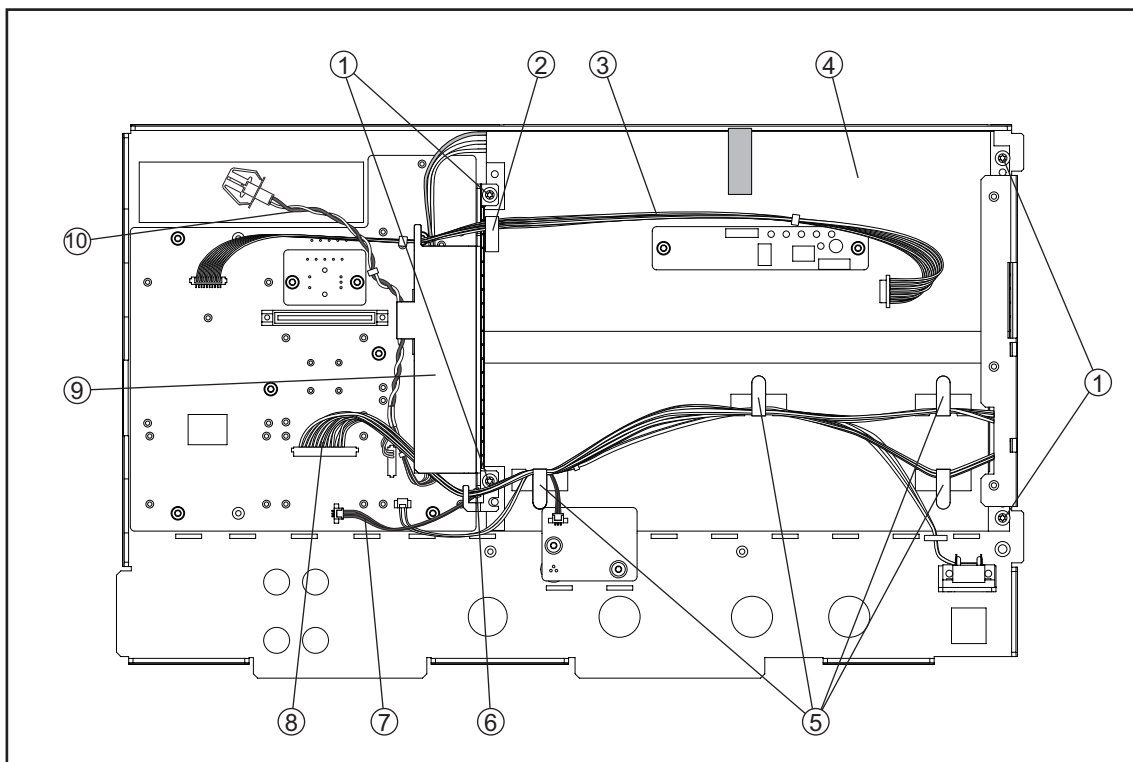

e5052bse1058

Table 5-29 Front Assembly (LCD)

Ref. Desig.	Agilent Part Number	Qty.	Description
1	0515-1402	4	SCREW-MACH M3.5 x L8 PN T15
2	1400-3361	1	CLAMP-CABLE 16MM
3	E5070-61628	1	WIRE ASSY
4	E5070-60112	1	LCD-TPANEL ASSY
5	1400-1334	4	CLAMP-CABLE STL
6	1400-0249	1	CABLE TIE
7	E5052-61655	1	WIRE ASSY
8	E5071-61616	1	FLAT CBL ASSY LCD
9	See Table 5-32	1	INVERTER ASSY
10	E5052-61652	1	WIRE ASSY

Front Assembly (Standby Switch and PCA Prove Power)

Figure 5-31 Front Assembly (Standby Switch and PCA Prove Power)

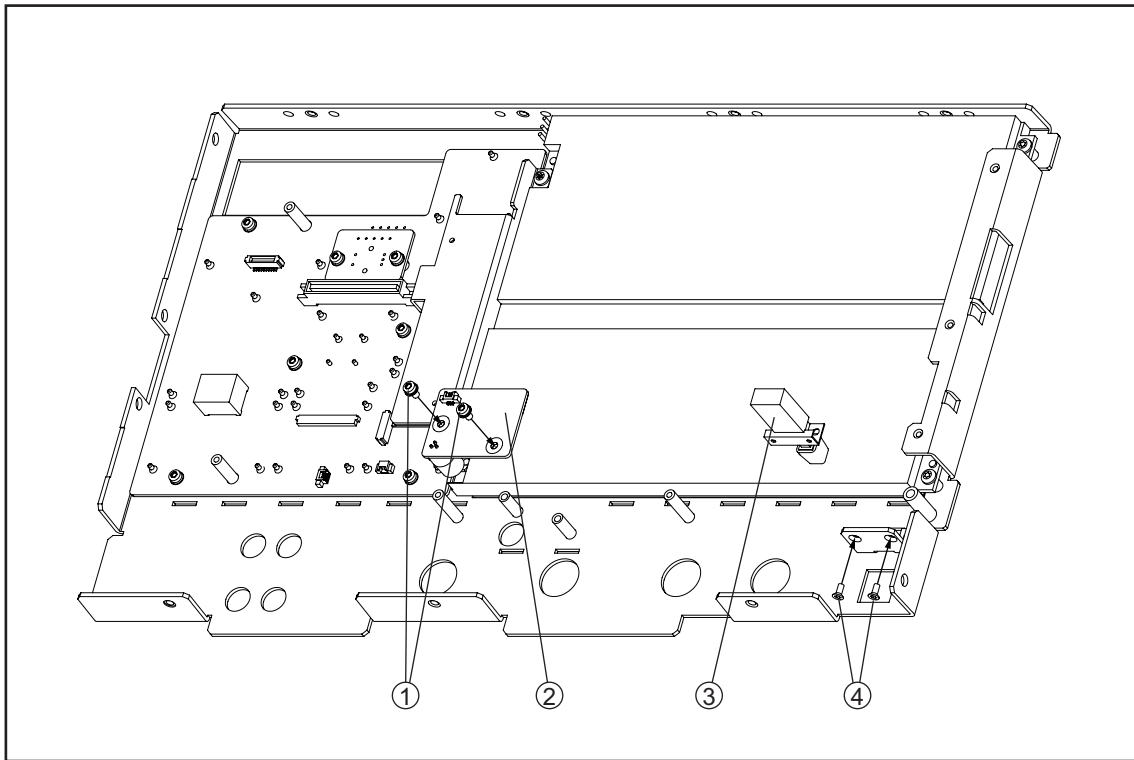

e5052bse1059

Table 5-30 Front Assembly (Standby Switch and PCA Prove Power)

Ref. Desig.	Agilent Part Number	Qty.	Description
1	0515-0430	2	SCREW-MACH M3.0 x L6 PN T10
2	E5052-66558	1	PCA PROBE POWER
3	E5070-61901	1	WIRE ASSY W/SW
4	0515-2028	2	SCREW-MACH M2.5 x L6 PN T8

Front Assembly (Front Keyboard)

Figure 5-32 Front Assembly (Front Keyboard)

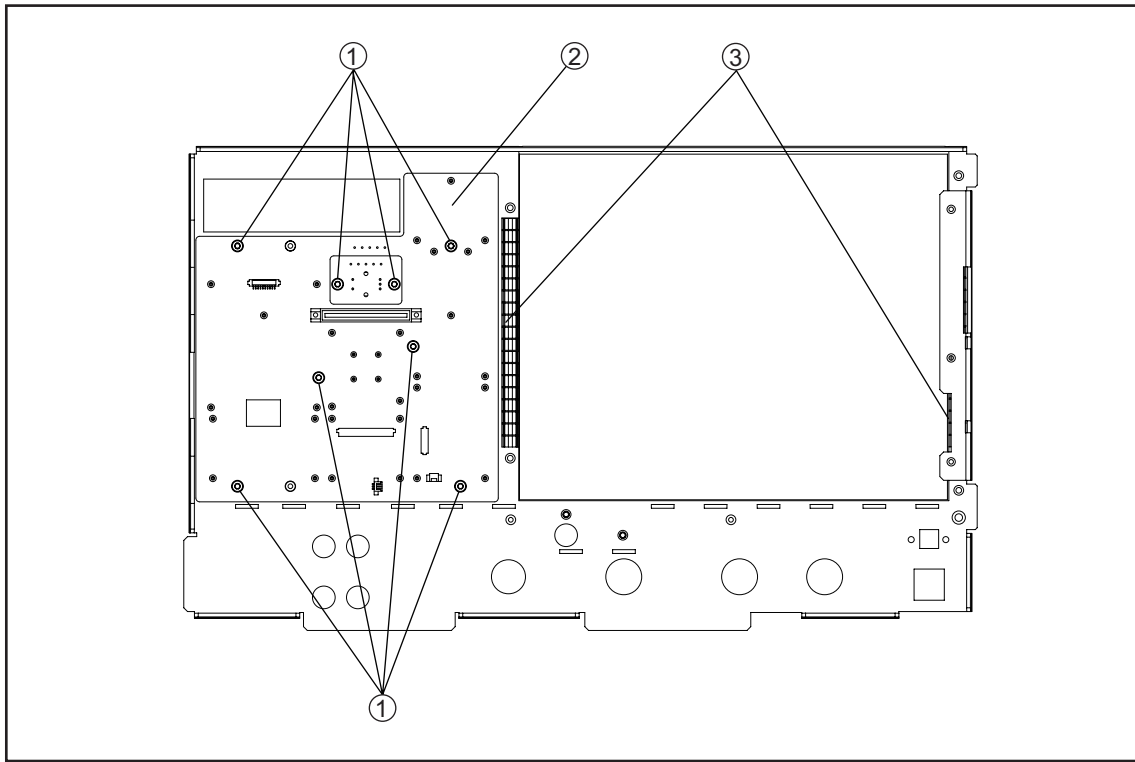

e5052bse1060

Table 5-31 Front Assembly (Front Keyboard)

Ref. Desig.	Agilent Part Number	Qty.	Description
1	0515-0430	8	SCREW-MACH M3.0 x L6 PN T10
2	E5070-66552	1	PCA FRONT KEY
3	0363-0170	2	GASKET 19-UNITS

Front Assembly (Inverter)

Figure 5-33

Front Assembly (Inverter)

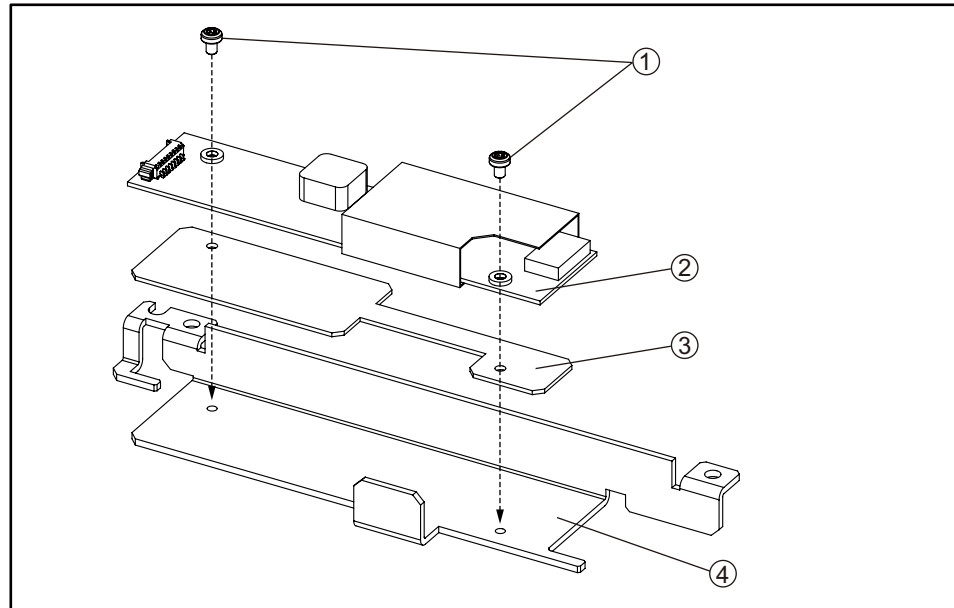

e5052bse1061

Table 5-32

Front Assembly (Inverter)

Ref. Desig.	Agilent Part Number	Qty.	Description
1	0361-1898	2	RIVET-PUSH-IN 4.2 MM
2	0950-4420	1	INVERTER DC-AC
3	E5052-00603	1	SPACER
4	E5052-01299	1	BRACKET INVERTER

Label on Front Face

Figure 5-34

Label on Front Face

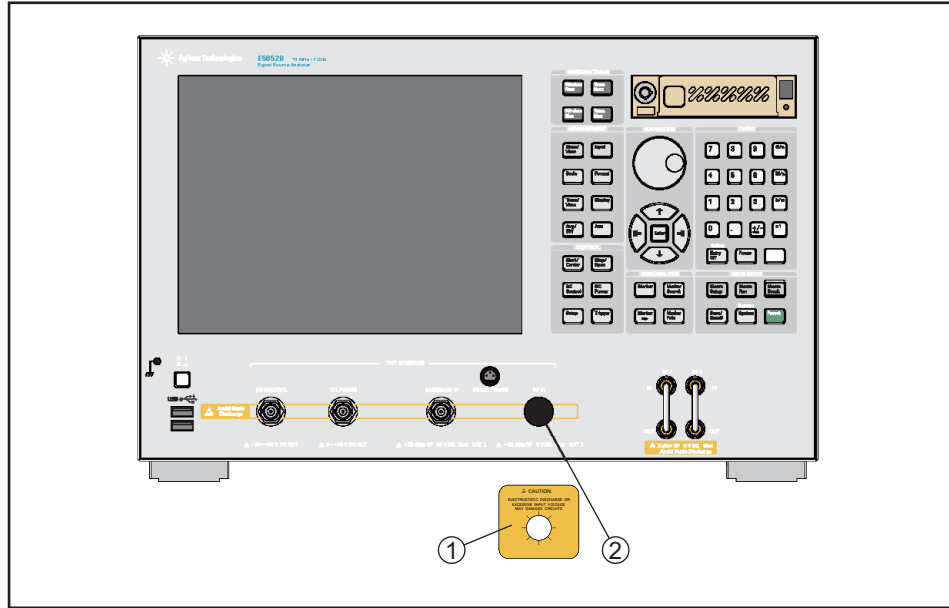

e5052bse1062

Table 5-33

Label on Front Face

Ref. Desig.	Agilent Part Number	Qty.	Description
1	E5070-87104	1	LABEL (CAUTION)
2	1401-0247	1	CAP-PROT

Label on Rear Face

Figure 5-35

Label on Rear Face

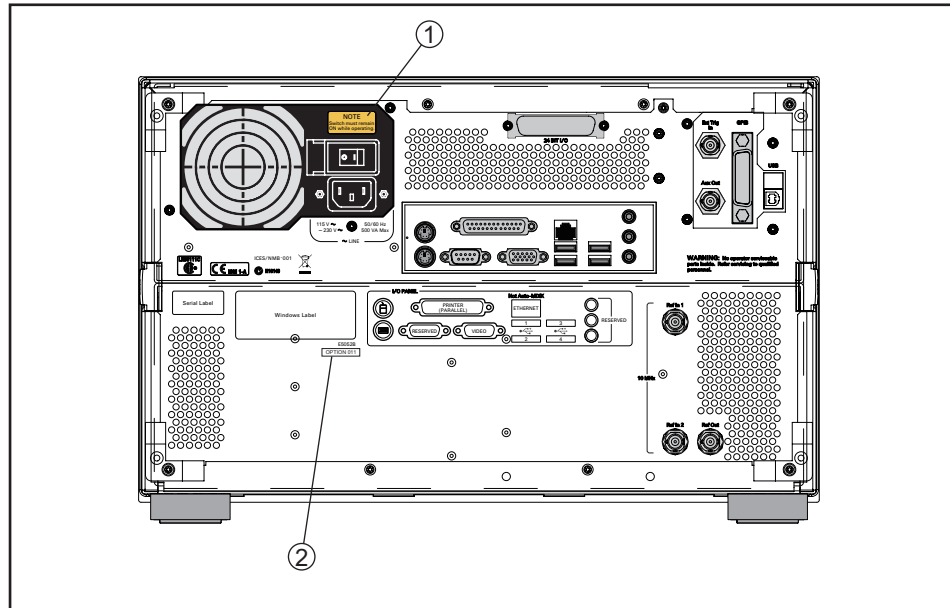

e5052bse1063

Table 5-34

Label on Rear Face

Ref. Desig.	Agilent Part Number	Qty.	Description
1	E5070-87103	1	LABEL (NOTE for Switch)
2	5183-4088	1	LABEL (OPTION 011)

Other Parts

Table 5-35 **Other Parts**

Agilent Part Number	Qty.	Description
E5052-901x0 ^{*1}	1	SERVICE GUIDE
1150-7799	1	MOUSE
5188-4407	1	KEYBOARD

*1. The number indicated by “x” in the part number of each manual, or CD-ROM, 0 for the first edition, is incremented by 1 each time a revision is made. The latest edition comes with the product.

6 Replacement Procedure

This chapter provides procedure for removing and replacing the major assemblies in the E5052B.

Replacing an Assembly

The following steps show the sequence for replacing an assembly in a E5052B Signal Source Analyzer.

1. Identify the faulty group. Refer to Chapter 4, “Troubleshooting.”
2. Order a replacement assembly. Refer to Chapter 5, “Replaceable Parts.”
3. Replace the faulty assembly and determine what adjustments are necessary. Refer to This chapter and Chapter 7, “Post-Repair Procedures.”
4. Perform the necessary adjustments. Refer to Chapter 3, “Adjustment.”
5. Perform the necessary performance tests. Refer to Chapter 2, “Performance Tests.”

WARNING These servicing instructions are for use by qualified personnel only. To avoid electrical shock, do not perform any servicing unless you are qualified to do so.

WARNING The opening of covers or removal of parts is likely to expose dangerous voltages. Disconnect the instrument from its power supply.

CAUTION Many of the assemblies in this instrument are very susceptible to damage from ESD(electrostatic discharge). Perform the following procedures only at a static-safe workstation and wear a grounding strap.

Please refer to the following table for the tightening torque of screws if no torque is specified by this chapter.

Screw	Driver	Recommended Torque
M2.5	T8	0.56 N-m (5.0 lb-in)
M3	T10	1.02 N-m (9.0 lb-in)
M3.5	T15	1.58 N-m (14.0 lb-in)
M4	T20	2.37N-m (21.0 lb-in)

Required Tools

The following tools are required for repair of the E5052B.

Table 6-1 Required Tools

Assembly	TORX screwdriver				flat edge screwdriver	10 mm torque wrench	cutting Plier	hex key	open-end torque wrench			
	T8	T10	T15	T20					1.5 mm	9/16 in.	5/8 in.	5/16 in.
Outer Cover		√	√	√								
Front Panel		√	√	√	√							√
Removable Hard Disk Assembly		√	√	√								
Removable Hard Disk Drive		√	√									
Power Supply		√	√	√								
Digital Bridge		√	√	√								
24 bit I/O		√	√	√								
PCI DSP / GPIB		√	√	√						√		
USB Interface		√	√	√								
Oven CH1		√	√	√								
Oven CH2		√	√	√								
DC Block		√	√	√	√							√
Fan		√	√	√	√	√	√					√
Power Distribution		√	√	√								
Digital Motherboard		√	√	√						√		
Freq / Power Detector		√	√	√	√							√
DC source		√	√	√	√							√
ADC/DSP		√	√	√	√							√
Local Synthesize		√	√	√	√							√
Phase Detector		√	√	√	√							√
Analog Motherboard		√	√	√	√				√			√
Front Panel		√	√	√	√							√
Control Touch Panel		√	√	√	√							√
Inverter		√	√	√	√							√
LCD		√	√	√	√							√
Front Panel Keyboard		√	√	√	√			√				√
Front USB PCA		√	√	√	√							√
Probe Power and Power Switch Board	√	√	√	√	√							√
Front BNC Connector		√	√	√	√		√		√			√

Outer Cover Removal

Tools Required

- TORX screwdriver, T10, T15 and T20

Procedure

Refer to Figure 6-1 for this procedure.

- Step 1.** Disconnect the power cable from the E5052B.
- Step 2.** Remove the four bottom feet (item 1).
- Step 3.** Remove the four TORX T10 screws (item 2) from the bottom.
- Step 4.** Remove the four TORX T20 screws (item 3) fastening the side strap handles.
- Step 5.** Remove the four TORX T15 screws (item 4) fastening the four rear foot
- Step 6.** Remove the four TORX T15 screws (item 5) fastening the cover.
- Step 7.** Slide the outer cover and remove it carefully.

Figure 6-1 Outer Cover Removal

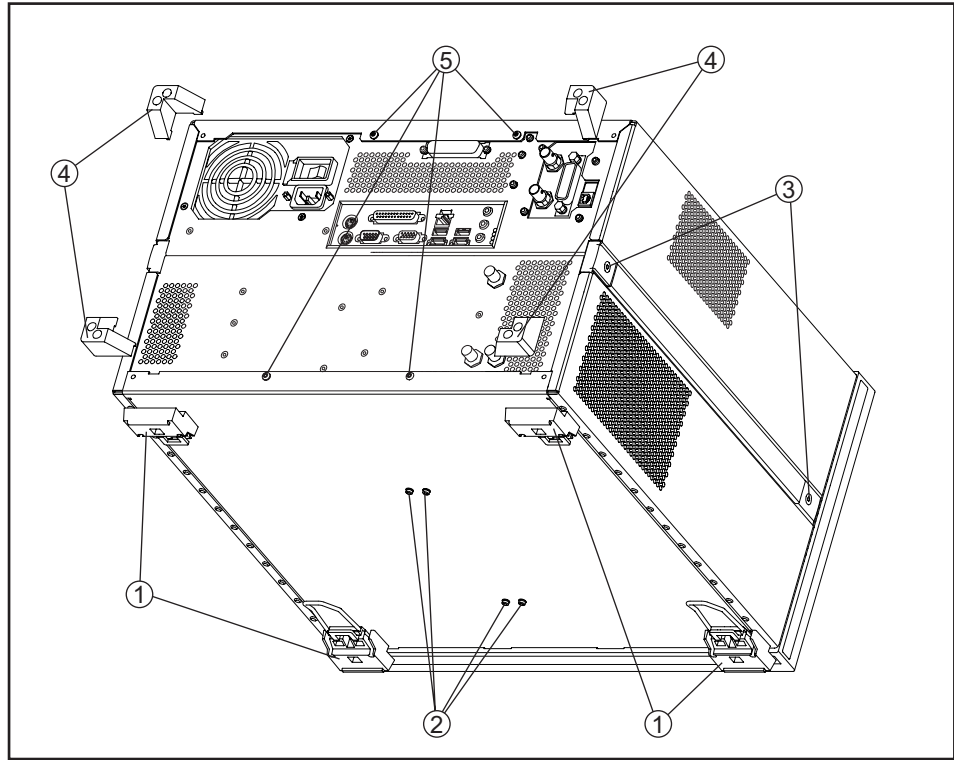

e5052bse1064

Front Panel Removal

Tools required

- TORX screwdriver T10, T15 and T20
- Flat edge screwdriver
- Open torque wrench, 5/16 inch (set to 10 in-lb) (for reconnecting SMA connector)

Procedure

Refer to Figure 6-2 for this procedure.

- Step 1.** Remove the outer cover as described in “Outer Cover Removal” on page 140.
- Step 2.** Disconnect the two semi-rigid cables (item 1) from the front panel.

NOTE

When reconnecting the semi-rigid cables, make sure that the cables are connected to the same connectors from which they previously came.

- Step 3.** Remove the top trim (item 2) using a flat edge driver.
- Step 4.** Remove the seven TORX T15 screws (item 3) fastening front panel.
- Step 5.** Release the flat cables from the cable clamps (item 4).
- Step 6.** Gradually push the front panel assembly towards the outside.
- Step 7.** Disconnect the cable (red and black) (item 5) from the front panel.
- Step 8.** Disconnect the cable (item 6) from the front panel.

Figure 6-2 Front Panel Removal

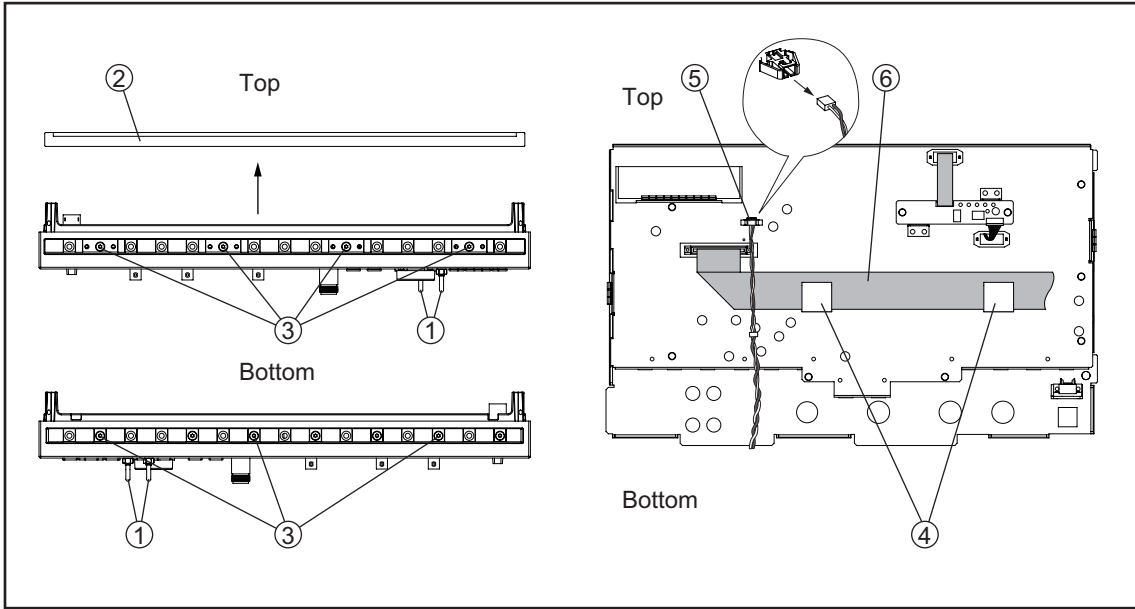

e5052bse1065

A27 Removable Hard Disk Assembly Removal

Tools Required

- TORX screwdriver T10, T15 and T20

Removal Procedure

Refer to Figure 6-3 for this procedure.

- Step 1.** Remove the outer cover as described in “Outer Cover Removal” on page 140.
- Step 2.** Release the clamped cable from the clamp (item 1) on the bracket HDD.
- Step 3.** Remove the two TORX T10 screws (item 2, 3) fastening the bracket HDD.
- Step 4.** Release the cables from the removable hard disk assembly (item 4).
- Step 5.** Lift the removable hard disk assembly.
- Step 6.** Remove the four TORX T10 screws (item 5) fastening the bracket HDD.

Figure 6-3 A27 Removable Hard Disk Assembly Removal

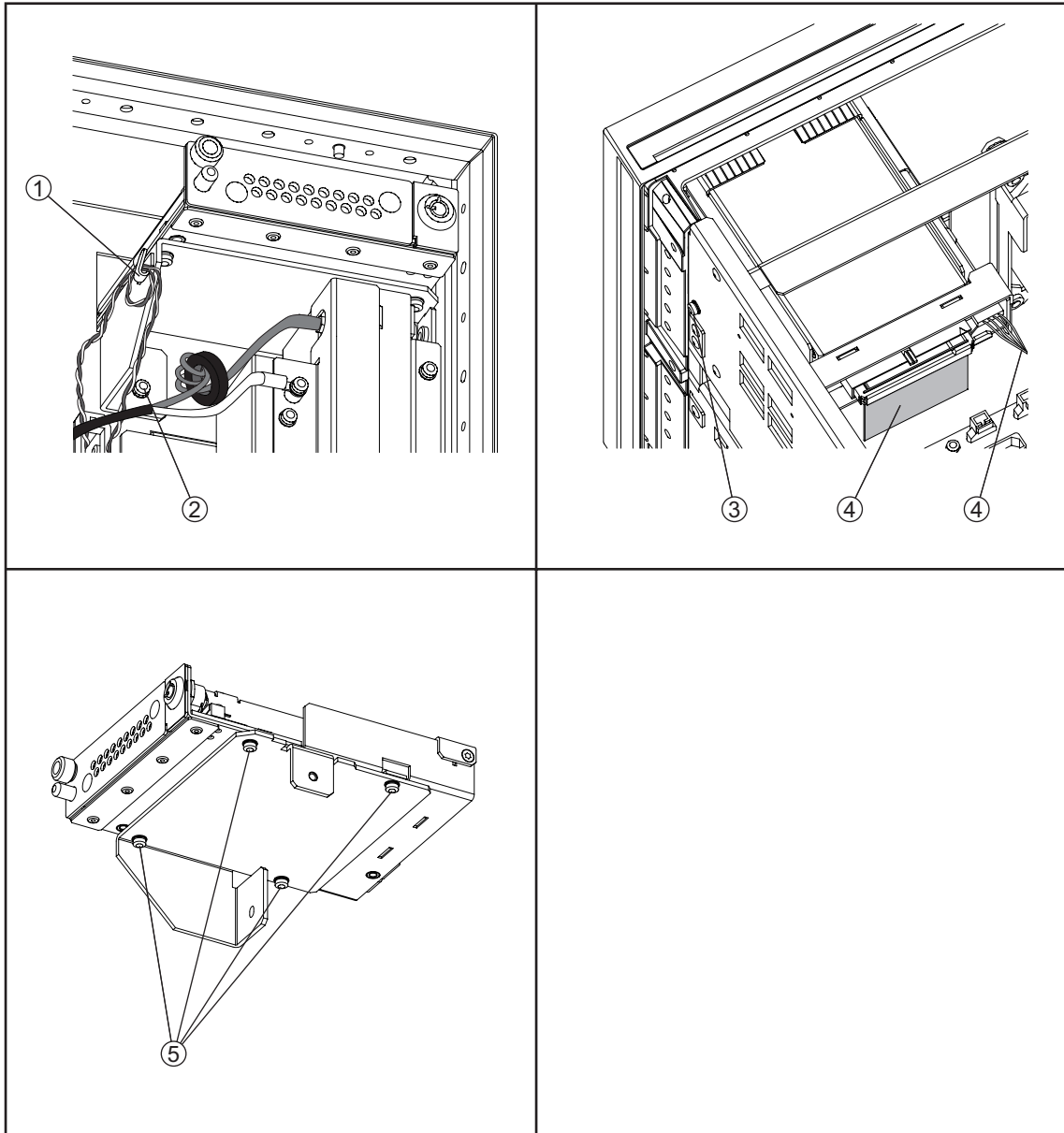

e5052bse1105

Removable Hard Disk Drive Replacement

Tools Required

- TORX screwdriver, T10
- Torque screwdriver, TORX T10

Save Backup Files to the PC

When the removable hard disk drive is readable, you have to perform the following steps. For details of the adjustment progra, refer to Chapter 6 on page 137.

- Step 1.** Run the adjustment program.
- Step 2.** Perform the adjustment using “Backup” in **Spot Adjustment** of the program.

Removal procedure

Refer to Figure 6-4 for this procedure.

- Step 1.** Insert the key (P/N 1390-1375) in the lock and turn clockwise (item 1).
- Step 2.** Loosen a screw (item 2).
- Step 3.** Press the button under the screw (item 3) and remove the hard disk (item 4).
- Step 4.** Remove the four TORX T10 screws (item 5), and remove the removable hard disk drive’s lid (item 6).
- Step 5.** Remove the four TORX T10 screws (item 7) fastening the HDD bracket and remove it.
- Step 6.** Remove the hard disk drive (item 8) from the connector board.

Figure 6-4 Removable Hard Disk Drive Removal

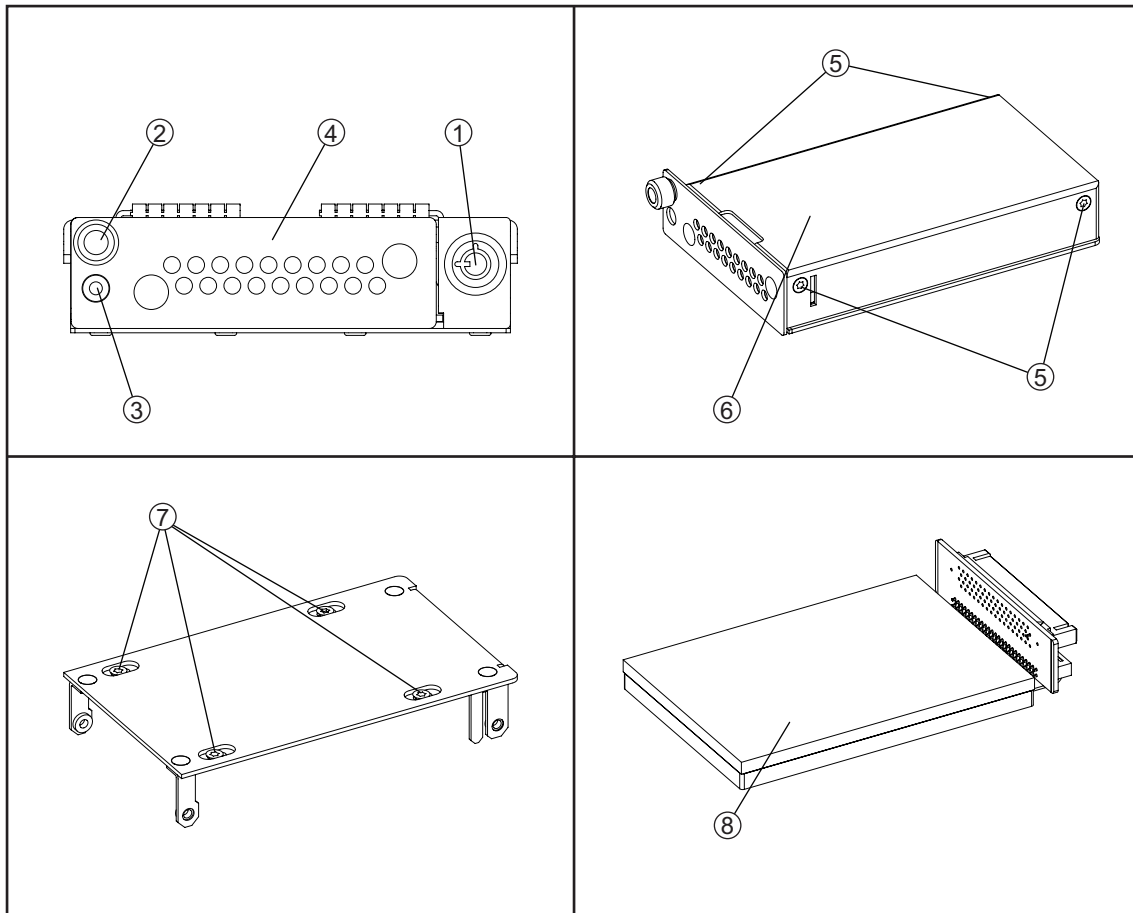

e5052bse1106

Replacement Procedure

Step 1. Replace the removable hard disk drive by inverse procedure of removal.

NOTE

Fasten the TORX T10 screws (item 5) using a torque screwdriver (set to 1.02 N-m / 9.0 lb-in).

Fasten the TORX T10 screws (item 6) using a torque screwdriver (set to 0.50 N-m / 4.4 lb-in).

Step 2. Insert the hard disk into the slot.

Step 3. Turn the key to the left until it is locked, then remove the key.

Step 4. When the “Backup” in Spot Adjustment has been done, restore backup files onto the new removable hard disk drive as described in “Restore Backup Files onto the New Removable Hard Disk Drive” on page 148.

Step 5. If the “Backup” in Spot Adjustment has not been done, restore backup files onto the new removable hard disk drive as described in “Adjustment for the New Removable Hard Disk Drive” on page 148.

Replacement Procedure

Removable Hard Disk Drive Replacement

Step 6. Calibrate the touch screen as described in “Calibration of the Touch Screen” on page 148.

Restore Backup Files onto the New Removable Hard Disk Drive

The backup files are stored into the PC. The file must be restored in the new removable hard disk drive with the adjustment program. For the details of the adjustment program, refer to Chapter 6 on page 137.

Step 1. Run the adjustment program.

Step 2. Perform the adjustment using “Recovery” in **Spot Adjustment** of the program.

Adjustment for the New Removable Hard Disk Drive

Step 1. Run the adjustment program.

Step 2. Perform the adjustment using “HDD” in **Spot Adjustment** of the program.

Calibration of the Touch Screen

When you have replaced the HDD on a E5052B equipped, you have to calibrate the touch screen. Follow the procedure described below to calibrate the touch screen.

Step 1. Press **[System]**.

Step 2. Press **Service Menu**.

Step 3. Press **Test Menu**.

Step 4. Press **Adjust Touch Screen**.

The touch screen calibration screen (Figure 6-5) appears.

Figure 6-5

Touch Panel Calibration Screen

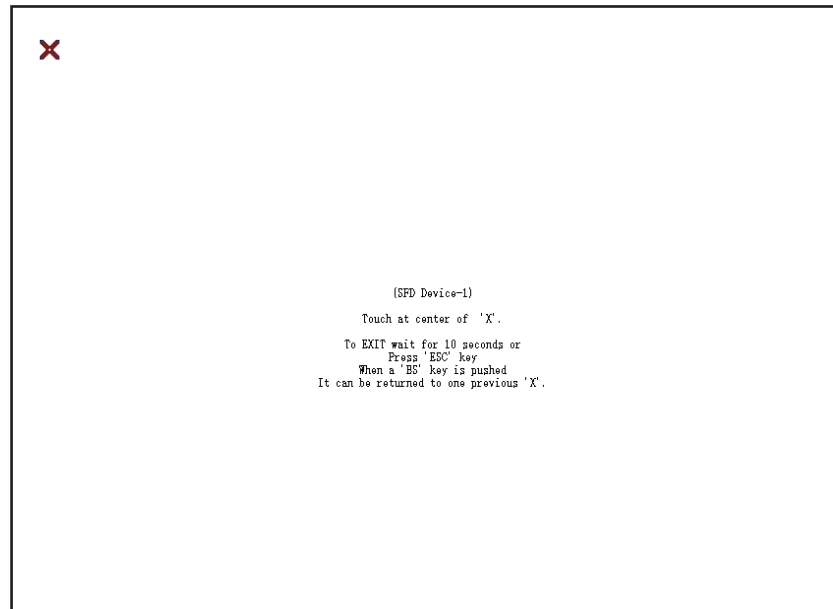

e5071cse1078

Replacement Procedure

Removable Hard Disk Drive Replacement

- Step 5.** Touch the x mark on the upper left with your finger. The mark x appears also on the lower left, upper right, and lower right. Touch the x marks in that order with your finger.

Touching the four locations described above with your finger automatically concludes the touch screen calibration.

NOTE

With no operation on the touch screen calibration screen for a preset time, it automatically closes and the previous measurement screen reappears.

Power Supply Assembly Replacement

Tools Required

- TORX screwdriver, T10, T15, and T20

Removal Procedure

Refer to Figure 6-6 for this procedure.

- Step 1.** Remove the outer cover as described in “Outer Cover Removal” on page 140.
- Step 2.** Remove the three TORX T10 screws (item 1) from the rear panel.
- Step 3.** Disconnect the power supply cables (item 2).
- Step 4.** Remove the two TORX T20 screws (item 3) fastening the plate for power supply.
- Step 5.** Lift the power supply assembly toward front side.

Figure 6-6 Power Supply Assembly Removal

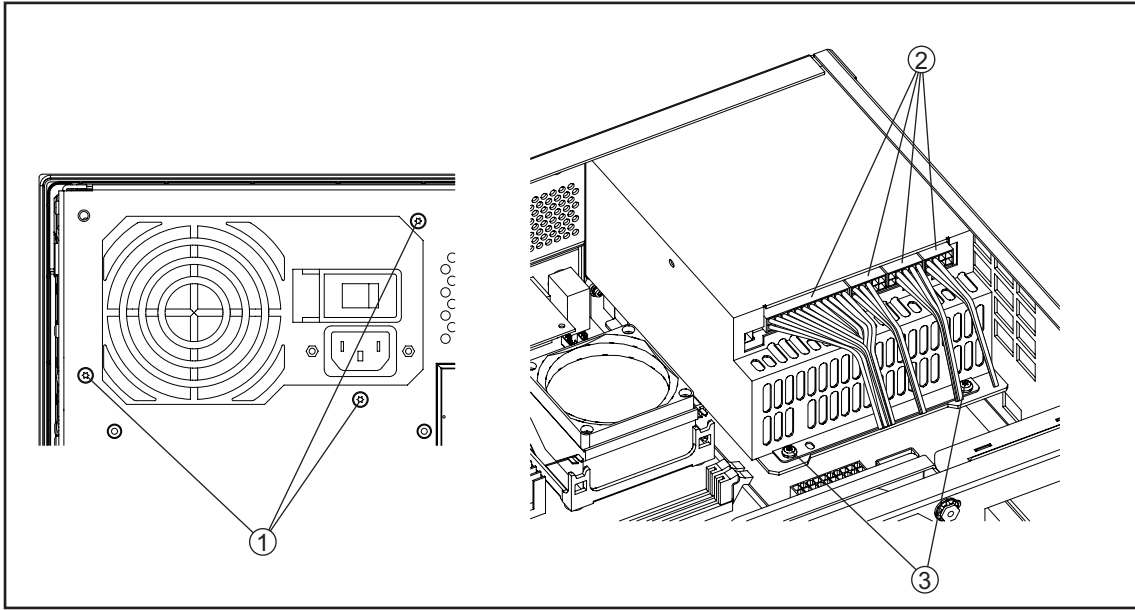

e5052bse1066

Replacement Procedure

Step 1. Replace the power supply assembly by inverse procedure of removal.

NOTE

Fasten the TORX T10 screws (item 1) using a torque screwdriver (set to 0.79 N-m / 7.0 lb-in).

A26 Digital Bridge Board Replacement

Tools Required

- TORX screwdriver, T10, T15, and T20

Removal Procedure

Refer to Figure 6-7 for this procedure.

- Step 1.** Remove the outer cover as described in “Outer Cover Removal” on page 140.
- Step 2.** Remove the three TORX T10 screws (item 1) fastening the angle.
- Step 3.** Disconnect the flat cable (item 2) from the PCI DSP card.
- Step 4.** Disconnect the flat cables (item 3) from the digital bridge board.
- Step 5.** Remove the two TORX T10 screws (item 4) fastening the board to the rear panel.
- Step 6.** Lift the digital bridge board (item 5).
- Step 7.** Disconnect the cables (item 6) from the digital bridge board.
- Step 8.** Remove the two TORX T10 screws (item 7) fastening the angle.

Figure 6-7 A26 Digital Bridge Board Removal

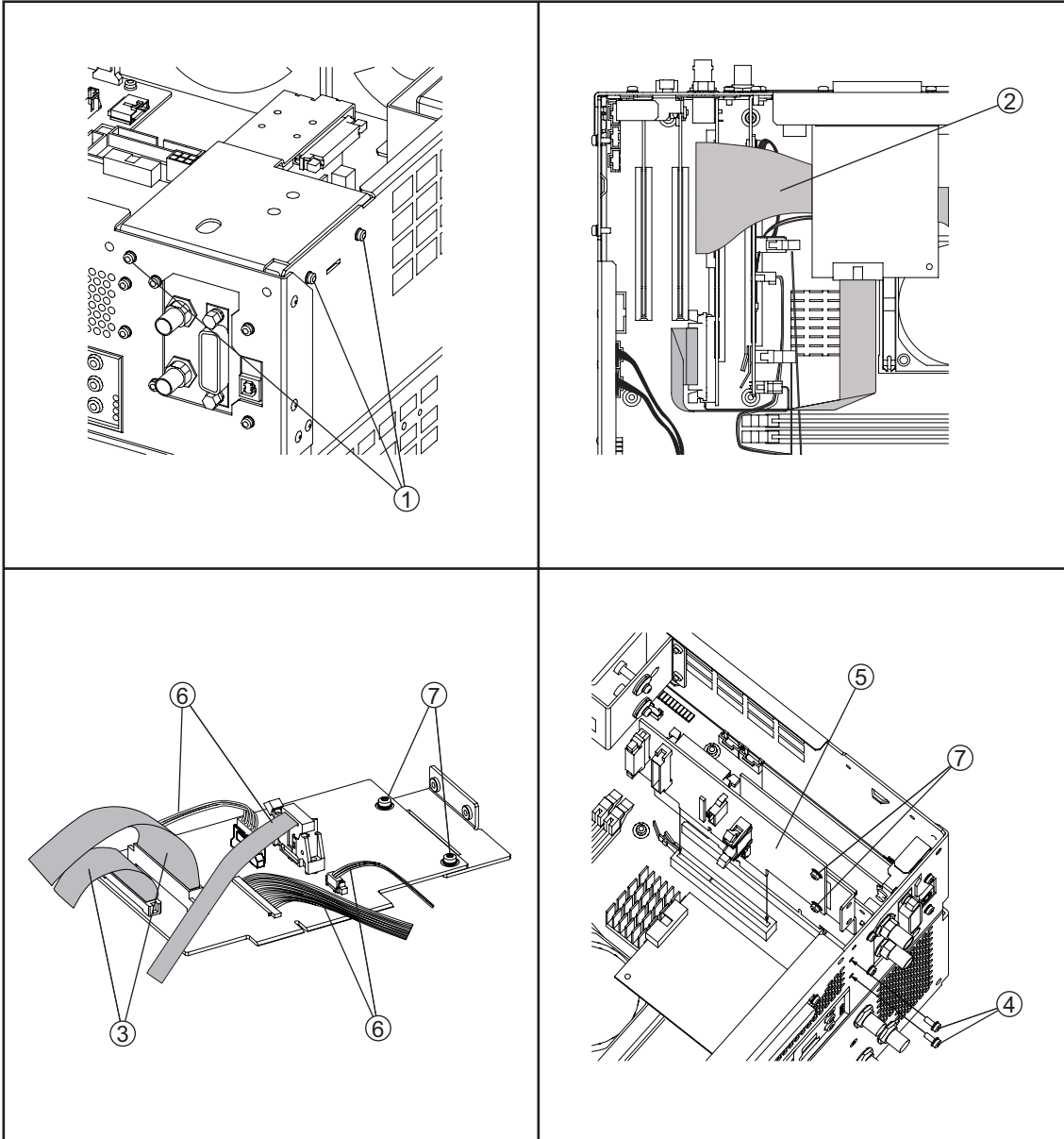

e5052bse1067

Replacement Procedure

Step 1. Replace the digital bridge board by inverse procedure of removal.

A25 24 bit I/O Board Replacement

Tools Required

- TORX screwdriver, T10, T15, and T20

Removal Procedure

Refer to Figure 6-8 for this procedure.

- Step 1.** Remove the outer cover as described in “Outer Cover Removal” on page 140.
- Step 2.** Disconnect the flat cable (item 1) from the 24 bit I/O board.
- Step 3.** Remove the two TORX T10 screws (item 2) fastening the 24 bit I/O board.
- Step 4.** Slide the 24 bit I/O board.

Figure 6-8 A25 24 bit I/O Board Removal

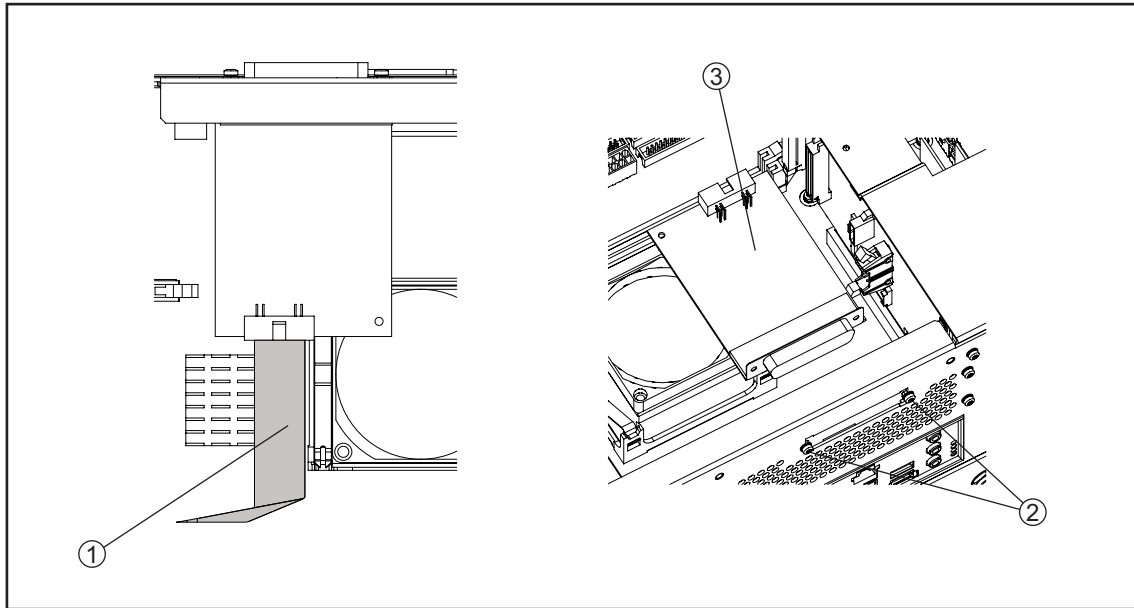

e5052bse1068

Replacement Procedure

Step 1. Replace the 24 bit I/O board by inverse procedure of removal.

A21 PCI DSP / A24 GPIB Card Replacement

Tools Required

- TORX screwdriver, T10, T15, and T20
- Open-end torque wrench, 5/8 inch (set to 1.97 N-m / 17.4 lb-in)

Removal Procedure

Refer to Figure 6-9 for this procedure.

- Step 1.** Remove the outer cover as described in “Outer Cover Removal” on page 140.
- Step 2.** Remove the three TORX T10 screws (item 1) fastening the angle.
- Step 3.** Disconnect the flat cable (item 2) from the PCI DSP card.
- Step 4.** Disconnect the flat cable (item 3) from the PCI DSP card.
- Step 5.** Disconnect the flat cable (item 4) from the PCI DSP card.
- Step 6.** Remove the four TORX T10 screws (item 5) fastening the PCI DSP card/GPIB card assembly to the rear panel.
- Step 7.** Lift the PCI DSP card/GPIB card assembly (item 6) from the digital motherboard carefully.
- Step 8.** Remove the PCI DSP card or GPIB card.

For removing the PCI DSP Card.

- Remove the 5/8 inch nut (item 7) fastening the angle.

For removing the GPIB Card.

- Remove the two TORX T10 screws (item 8) fastening the angle.

Figure 6-9 A21 PCI / A24 GPIB Card Removal

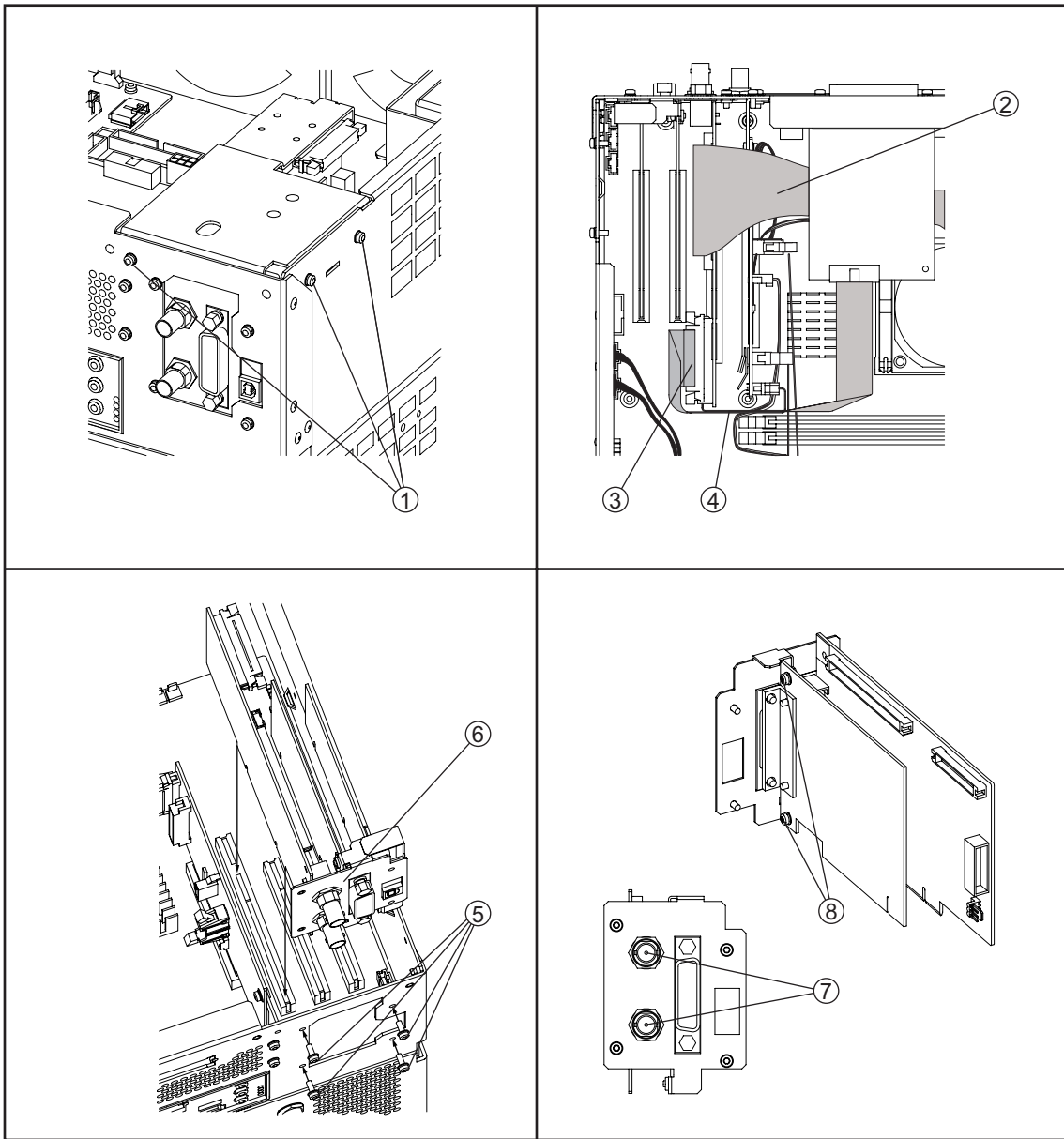

e5052bse1069

Replacement Procedure

Step 1. Replace the PCI / GPIB card by inverse procedure of removal.

NOTE

Fasten the 5/8 inch nut (item 7) using an open-end torque wrench for replacement.

A32 USB (USBTMC) Interface Card Replacement

Tools Required

- TORX screwdriver, T10, T15, and T20

Removal Procedure

Refer to Figure 6-10 for this procedure.

- Step 1.** Remove the outer cover as described in “Outer Cover Removal” on page 140.
- Step 2.** Remove the three TORX T10 screws (item 1) fastening the angle.
- Step 3.** Remove two TORX T10 screws (item 2) fastening the PCI DSP card/GPIB card assembly to the rear panel.
- Step 4.** Lift the USB (USBTMC) interface card (item 3) from the digital motherboard carefully.
- Step 5.** Remove the two TORX T10 screws (item 4) fastening the angle.

Figure 6-10 A32 USB (USBTMC) Interface Card Removal

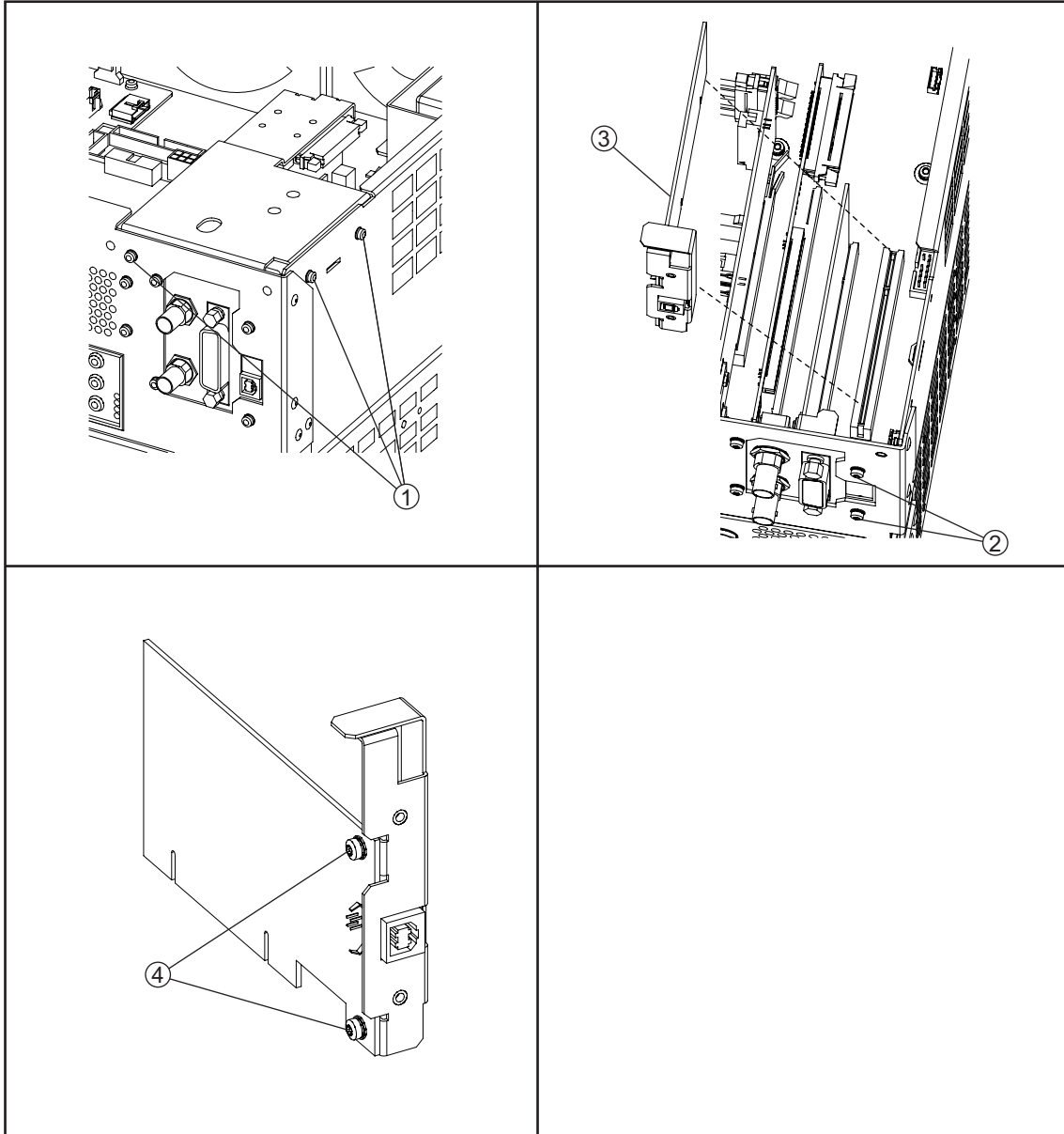

e5052bse1070

Replacement Procedure

Step 1. Replace the USB interface card by inverse procedure of removal.

Oven CH1 Assembly Replacement

Tools Required

- TORX screwdriver, T10, T15, and T20

Removal Procedure

Refer to Figure 6-11 for this procedure.

- Step 1.** Remove the outer cover as described in “Outer Cover Removal” on page 140.
- Step 2.** Remove the three TORX T10 screws (item 1) fastening the oven ch1 assembly.
- Step 3.** Disconnect the RF cable (item 2) from the oven ch1 assembly.
- Step 4.** Disconnect the cable (item 3) from the power distribution board.
- Step 5.** Lift the oven ch1 assembly (item 4).
- Step 6.** Remove the two TORX T10 screws (item 5) fastening the C-bracket.
- Step 7.** Remove the three TORX T10 screws (item 6) fastening the C-bracket.
- Step 8.** Remove the oven ch1 (item 7).
- Step 9.** Remove the L-bracket (item 8).

Figure 6-11 Oven CH1 Removal

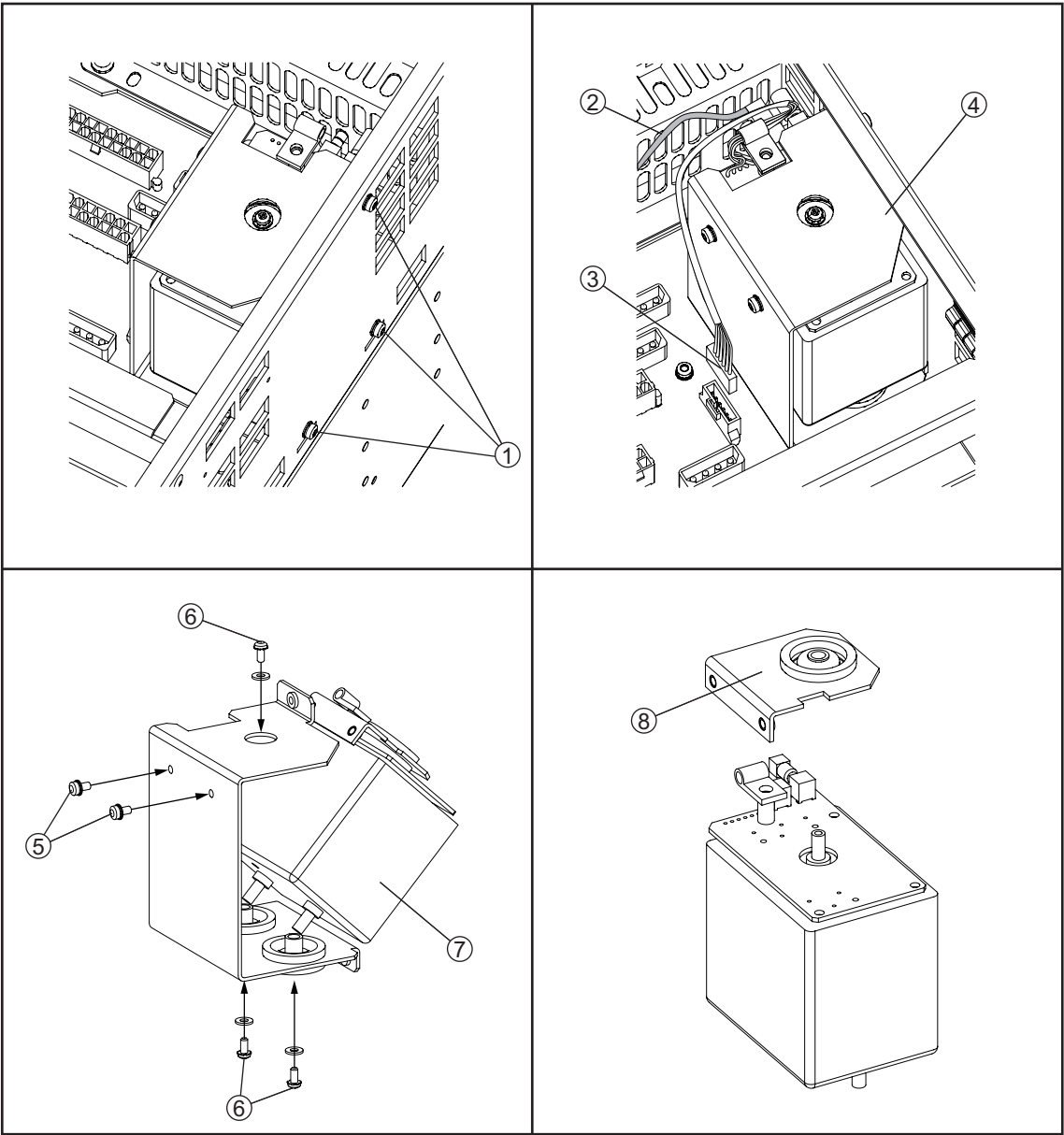

e5052bse1071

Replacement Procedure

Step 1. Replace the oven ch1 assembly by inverse procedure of removal.

Oven CH2 Assembly Replacement

Tools Required

- TORX screwdriver, T10, T15, and T20

Removal Procedure

Refer to Figure 6-12 for this procedure.

- Step 1.** Remove the outer cover as described in “Outer Cover Removal” on page 140.
- Step 2.** Remove the four TORX T10 screws (item 1) fastening the oven ch2 Assembly.
- Step 3.** Disconnect the RF cable (item 2) from the oven ch2 Assembly.
- Step 4.** Disconnect the cable (item 3) from the connector.
- Step 5.** Release the cable (item 4) from the cable clamp.
- Step 6.** Disconnect the connector (item 5) from the oven ch2 Assembly.
- Step 7.** Lift the oven ch2 Assembly (item 6).
- Step 8.** Remove the three TORX T10 screws (item 7) fastening the C-bracket.
- Step 9.** Remove the oven ch2 (item 8).

Figure 6-12 Oven CH2 Removal

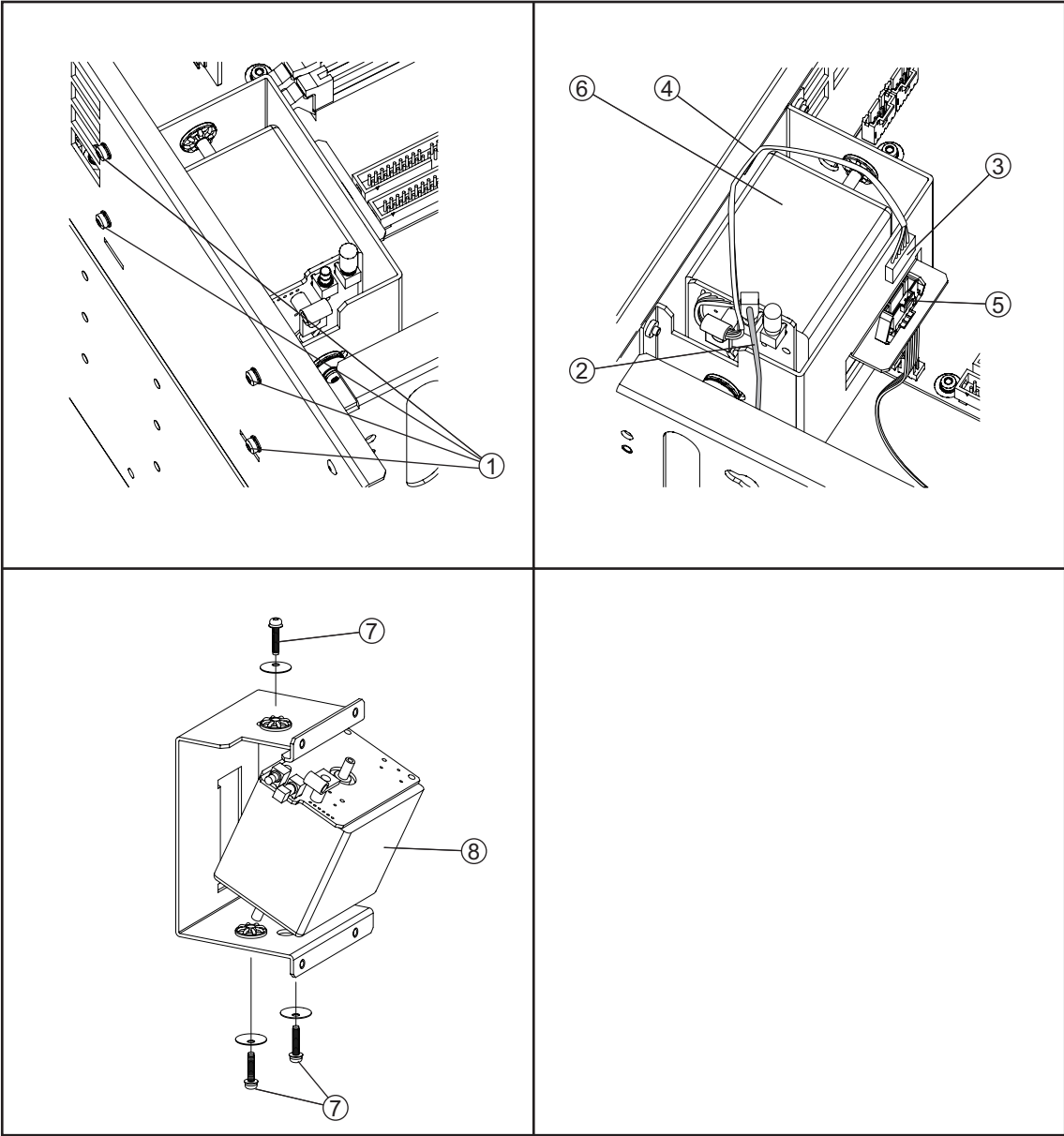

e5052bse1072

Replacement Procedure

Step 1. Replace the oven ch2 assembly by inverse procedure of removal.

A57 DC Block Assembly Replacement

Tools Required

- TORX screwdriver, T10, T15, and T20
- Flat edge screwdriver
- Open-end torque wrench, 5/8 inch (set to 1.97 N-m / 17.4 lb-in)

Removal Procedure

Refer to Figure 6-13 for this procedure.

- Step 1.** Remove the outer cover as described in “Outer Cover Removal” on page 140.
- Step 2.** Remove the front panel as described in “Front Panel Removal” on page 142.
- Step 3.** Disconnect the two cables (item 1) from the DC block assembly.
- Step 4.** Remove the two TORX T10 screws (item 2) fastening the DC block assembly and disconnect the two cables.
- Step 5.** Remove the three TORX T10 screws (item 3) fastening the DC block assembly.
- Step 6.** Pull the DC block assembly toward carefully (item 4).

Figure 6-13 A57 DC Block Removal

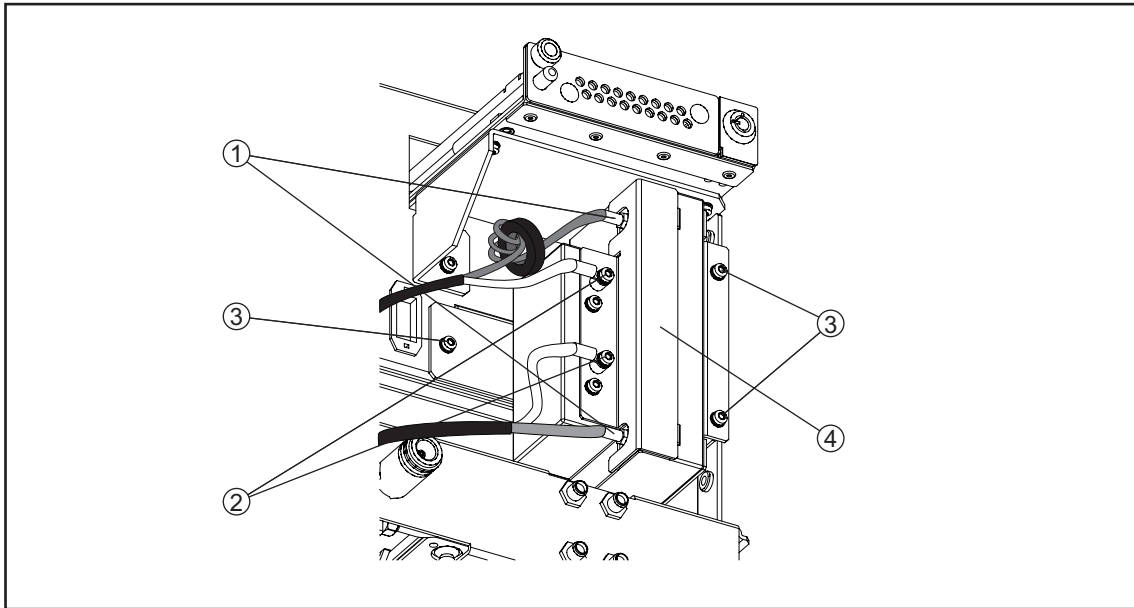

e5052bse1073

Replacement Procedure

Step 1. Replace the dc block by inverse procedure of removal.

Fan Replacement

Tools Required

- TORX screwdriver, T10, T15 and T20
- Flat edge screwdriver
- 10 mm torque open wrench (set to 1.02 N-m / 9.0 lb-in)
- Cutting plier
- Open-end torque wrench, 5/8 inch (set to 1.97 N-m / 17.4 lb-in)

Removal Procedure

Refer to Figure 6-14 for this procedure.

- Step 1.** Remove the outer cover as described in “Outer Cover Removal” on page 140.
- Step 2.** Remove the front panel as described in “Front Panel Removal” on page 142.
- Step 3.** Cut the cable tie (item 1).
- Step 4.** Release the cables from the cable clamp (item 2).
- Step 5.** Disconnect the fan cables (items 3, 4) from the power distribution board.
- Step 6.** Remove the four hex bolts (item 5) fastening the fan.
- Step 7.** Remove the fan from fan plate.
- Step 8.** Remove the angle (items 6, 7) from fan.

Figure 6-14 Fan Removal

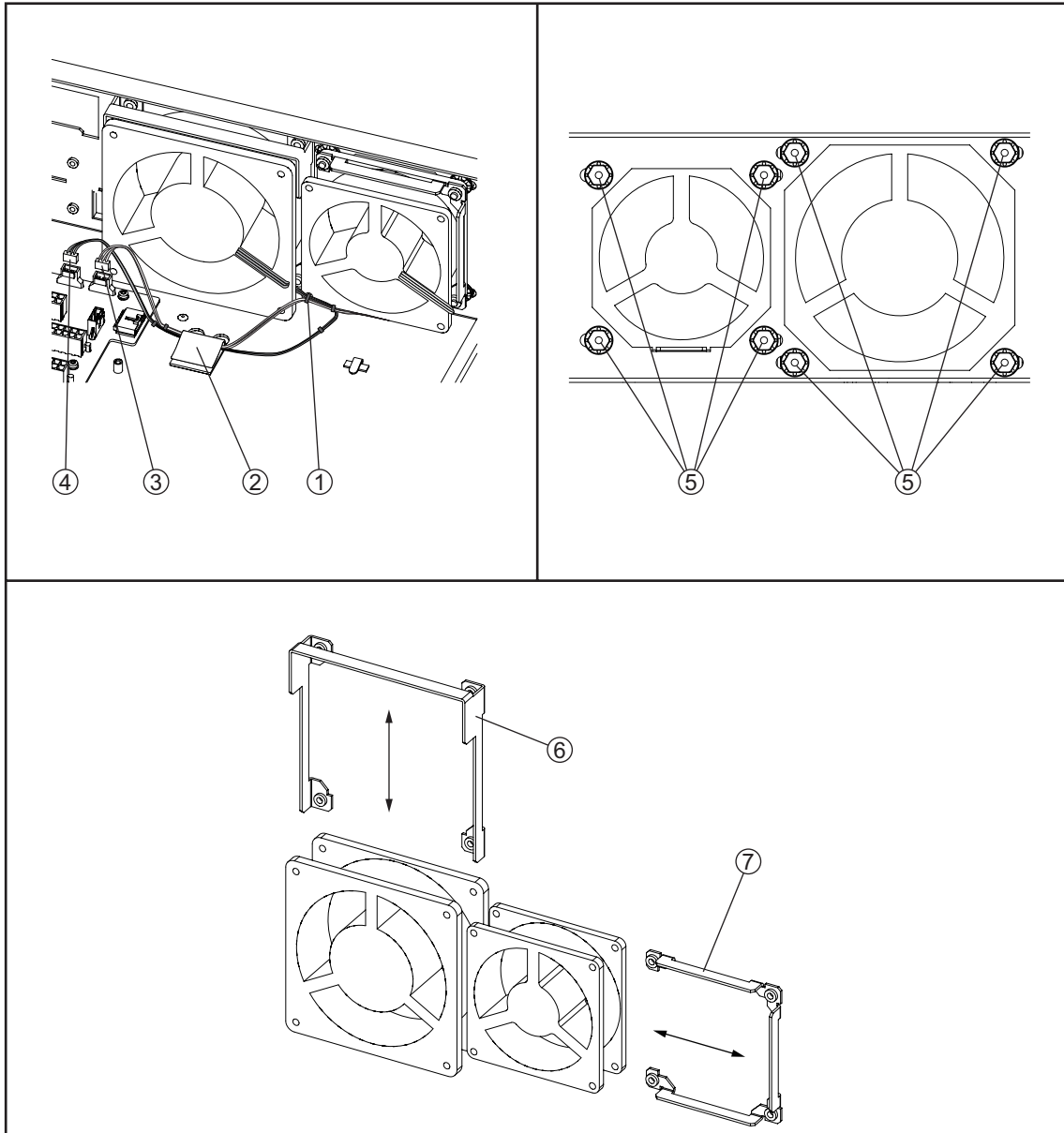

e5052bse1074

Replacement Procedure

Step 1. Replace the fan by inverse procedure of removal.

NOTE

Connecting the cables (items 3, 4) as described below.

- Connect the cable from small fan to “J5” connector (item 3).
- Connect the cable from big fan to “J6” connector (item 4).

A22 Power Distribution Board Replacement

Tools Required

- TORX screwdriver, T10, T15 and T20

Removal Procedure

Refer to Figure 6-15 for this procedure.

- Step 1.** Remove the outer cover as described in “Outer Cover Removal” on page 140.
- Step 2.** Remove the power supply as described in “Power Supply Assembly Replacement” on page 150.
- Step 3.** Disconnect the cables from the power distribution board.
- Step 4.** Remove the two TORX T10 screws (item 1) fastening the plate.
- Step 5.** Remove the plate (item 2) from the power distribution board.
- Step 6.** Remove the five TORX T10 screws (item 3) fastening the power distribution board.
- Step 7.** Slide the power distribution board (item 4) from the analog motherboard.

Figure 6-15 A22 Power Distribution Board Removal

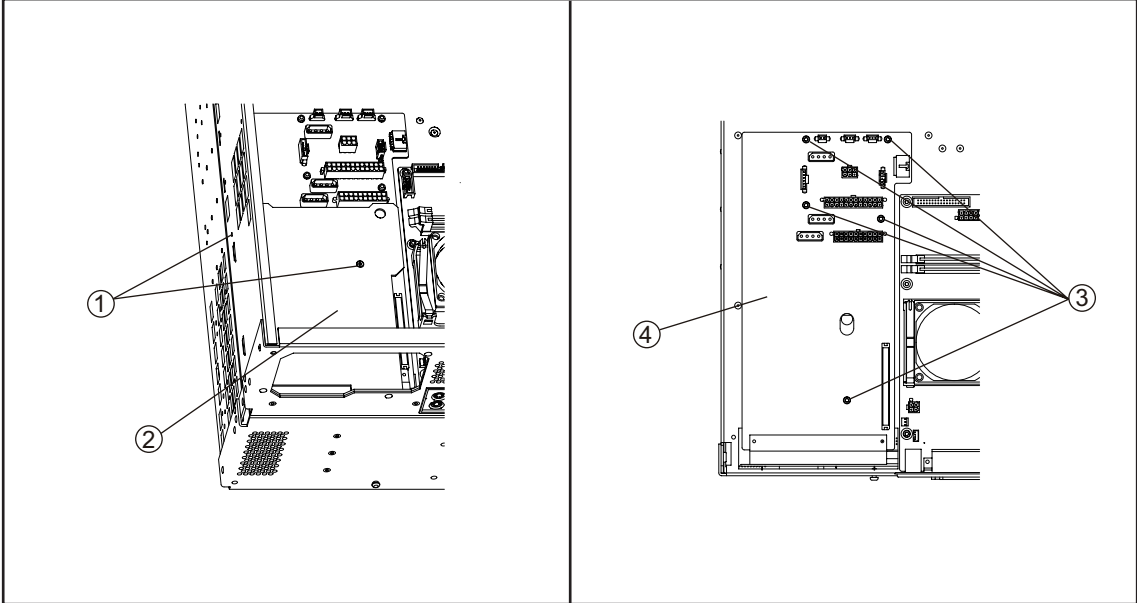

e5052bse1075

Replacement Procedure

Step 1. Replace the power distribution board by inverse procedure of removal.

A20 Digital Motherboard Replacement

Tools Required

- TORX screwdriver, T10, T15, and T20
- Open-end torque wrench, 5/8 inch (set to 1.97 N-m / 17.4 lb-in)

Removal Procedure

Refer to Figure 6-16 for this procedure.

- Step 1.** Remove the outer cover as described in “Outer Cover Removal” on page 140.
- Step 2.** Remove the following assemblies.
- Front Panel (refer to “Front Panel Removal” on page 142).
 - 24 Bit I/O board (refer to “A25 24 bit I/O Board Replacement” on page 154).
 - Digital Bridge board (refer to “A26 Digital Bridge Board Replacement” on page 152).
 - PCI DSP Card and GPIB Card (refer to “A21 PCI DSP / A24 GPIB Card Replacement” on page 156).
 - Oven ch2 assembly (refer to “Oven CH2 Assembly Replacement” on page 162).
- Step 3.** Disconnect all cables from the digital motherboard.
- Step 4.** Remove the eight TORX T10 screws (item 1) fastening the digital motherboard.
- Step 5.** Lift the digital motherboard slowly.

NOTE

Don't remove the CPU fan assembly and the DMM memory from digital motherboard.

Figure 6-16 A20 Digital Motherboard Removal

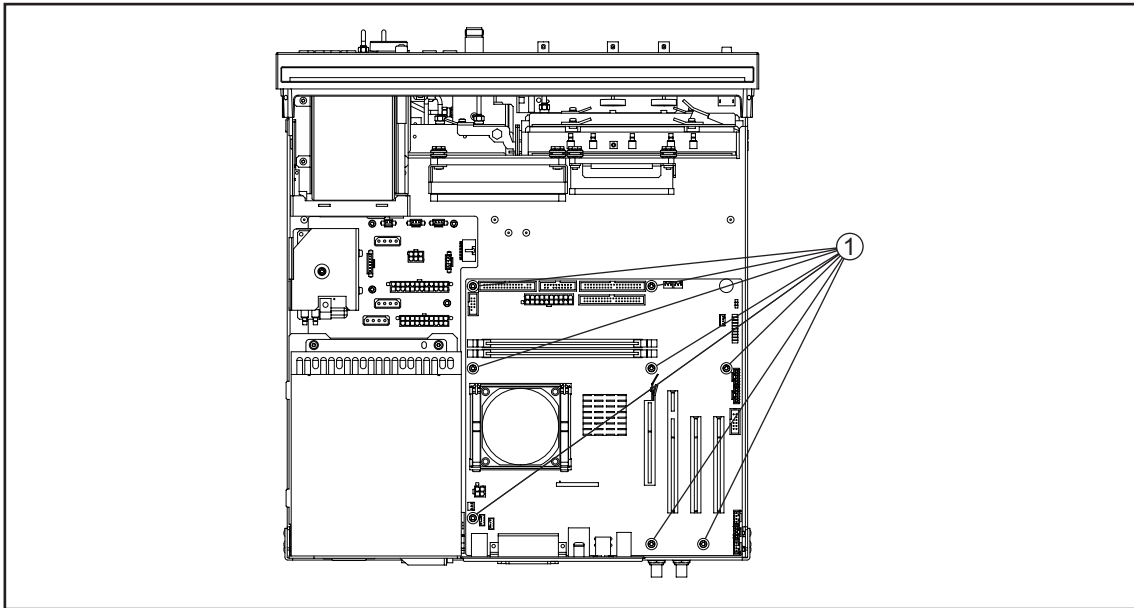

e5052bse1076

Replacement Procedure

Step 1. Replace the digital motherboard by inverse procedure of removal.

A1 Freq / Power Detector Module Replacement

Tools Required

- TORX screwdriver, T10, T15, and T20
- Flat edge screwdriver
- Open-end torque wrench, 5/16 inch (set to 1.02 N-m / 9.0 lb-in) (for reconnecting SMA connector)

Removal Procedure

Refer to Figure 6-17 for this procedure.

- Step 1.** Remove the outer cover as described in “Outer Cover Removal” on page 140
- Step 2.** Remove the front panel as described in “Front Panel Removal” on page 142.
- Step 3.** Disconnect the RF cable(item 1).
- Step 4.** Disconnect the semi-rigid cables(item 2).
- Step 5.** Disconnect the semi-rigid cable(item 3).
- Step 6.** Disconnect the semi-rigid cable(item 4).
- Step 7.** Remove the TORX T15 screw fastening the freq / power detector module bracket (item 5).
- Step 8.** Slide out the freq / power detector module (item 6).

Figure 6-17 A1 Freq/Power Detector Module Removal

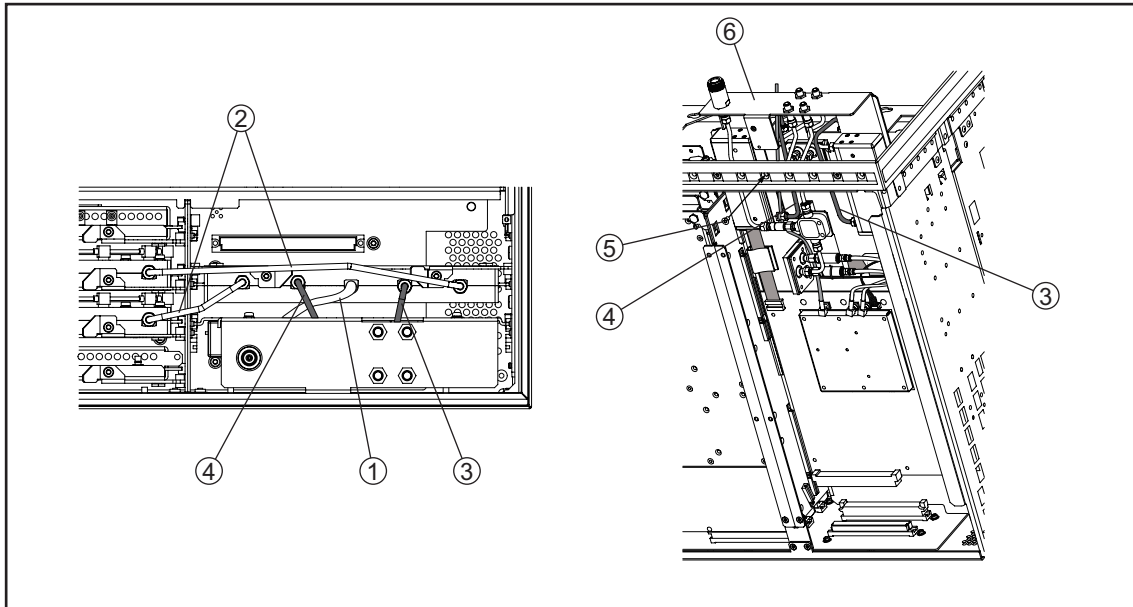

e5052bse1085

Replacement Procedure

Step 1. Replace the freq/power detector module by inverse procedure of removal.

NOTE

Fasten the semi-rigid cable using a open-end torque wrench for replacement.

A2 DC Source Board Replacement

Tools Required

- TORX screwdriver, T10, T15, and T20
- Flat edge screwdriver
- Open-end torque wrench, 5/16 inch (set to 1.02 N-m / 9.0 lb-in) (for reconnecting SMA connector)

Removal Procedure

Refer to Figure 6-18 for this procedure.

- Step 1.** Remove the outer cover as described in “Outer Cover Removal” on page 140
- Step 2.** Remove the front panel as described in “Front Panel Removal” on page 142.
- Step 3.** Remove the three TORX T15 screws (item 1).
- Step 4.** Disconnect the USB cables (item 2) from the front USB PCA.
- Step 5.** Remove the two TORX T10 screws (item 3) from the DC source board.
- Step 6.** A short slide out the DC source board.
- Step 7.** Disconnect the cables (item 4) and remove the two TORX T10 screws from the DC source board.
- Step 8.** Slide out the DC source board (item 5).

NOTE

Remove the BNC connector as described in “Front BNC Connector Replacement” on page 196.

Figure 6-18 A2 DC Source Board Removal

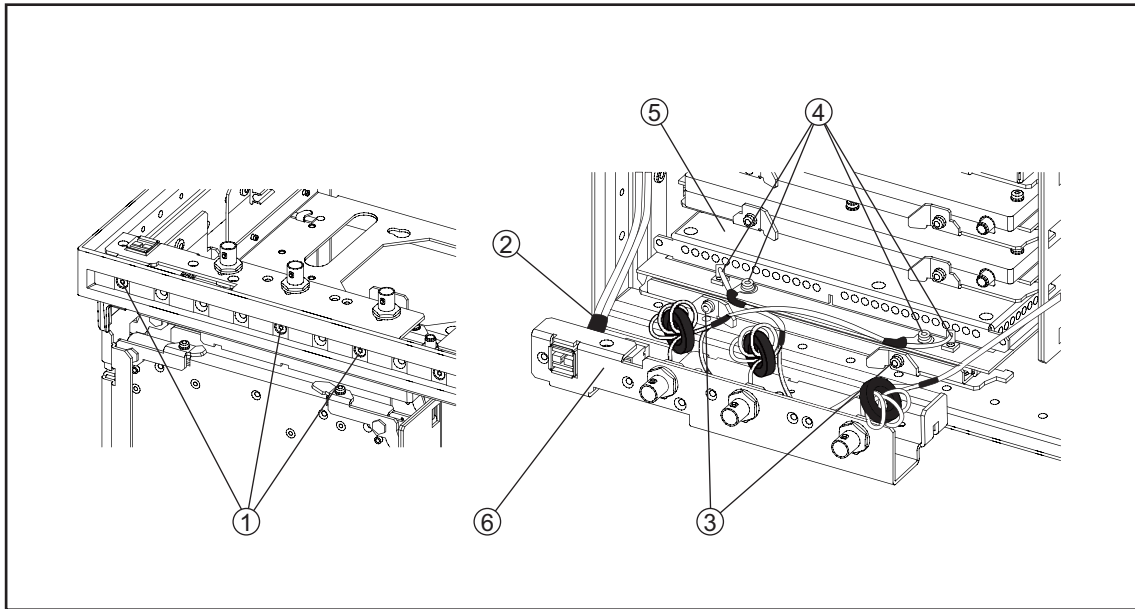

e5052bse1086

Replacement Procedure

Step 1. Replace the DC source board by inverse procedure of removal.

NOTE

Fasten the semi-rigid cable using a open-end torque wrench for replacement.

A3 ADC/DSP Board Replacement

Tools Required

- TORX screwdriver, T10, T15, and T20
- Flat edge screwdriver
- Open-end torque wrench, 5/16 inch (set to 1.02 N-m / 9.0 lb-in) (for reconnecting SMA connector)

Removal Procedure

Refer to Figure 6-19 for this procedure.

- Step 1.** Remove the outer cover as described in “Outer Cover Removal” on page 140
- Step 2.** Remove the front panel as described in “Front Panel Removal” on page 142.
- Step 3.** Release the clamped cables from the clamp (item 1).
- Step 4.** Disconnect the RF cables (item 2) from the ADC/DSP board.
- Step 5.** Remove the two TORX T10 screws (item 3).
- Step 6.** Slide out the ADC/DSP board (item 4).

Figure 6-19 A3 ADC/DSP Board Removal

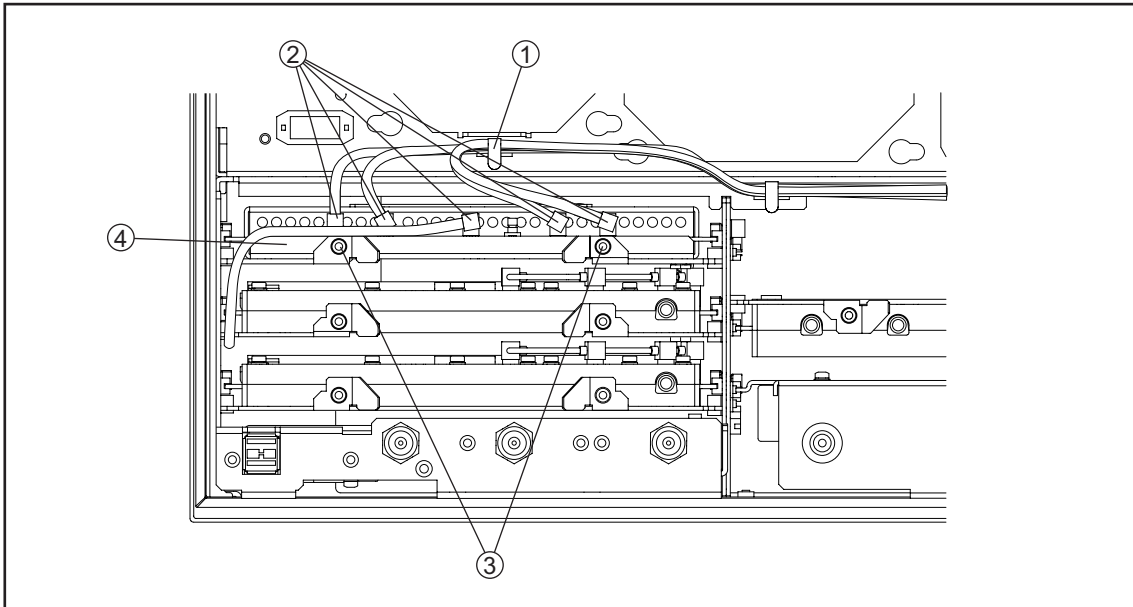

e5052bse1087

Replacement Procedure

Step 1. Replace the ADC/DSP board by inverse procedure of removal.

NOTE Fasten the semi-rigid cable using an open-end torque wrench for replacement.

A4/A5 Local Synthesize Module Replacement

Tools Required

- TORX screwdriver, T10, T15, and T20
- Flat edge screwdriver
- Open-end torque wrench, 5/16 inch (set to 1.02 N-m / 9.0 lb-in) (for reconnecting SMA connector)

Removal Procedure

Refer to Figure 6-20 for this procedure.

- Step 1.** Remove the outer cover as described in “Outer Cover Removal” on page 140.
- Step 2.** Remove the front panel as described in “Front Panel Removal” on page 142.
- Step 3.** Disconnect the semi-rigid cables (item 1).
- Step 4.** Remove each two TORX T10 screws (item 2) from the local synthesize module.
- Step 5.** Slide out the local synthesize module (item 3).
- Step 6.** Release the clamped cables from the clamp (item 4).
- Step 7.** Disconnect the RF cable (item 5) from the local synthesize module.

Figure 6-20 A4/A5 Local Synthesize Module Removal

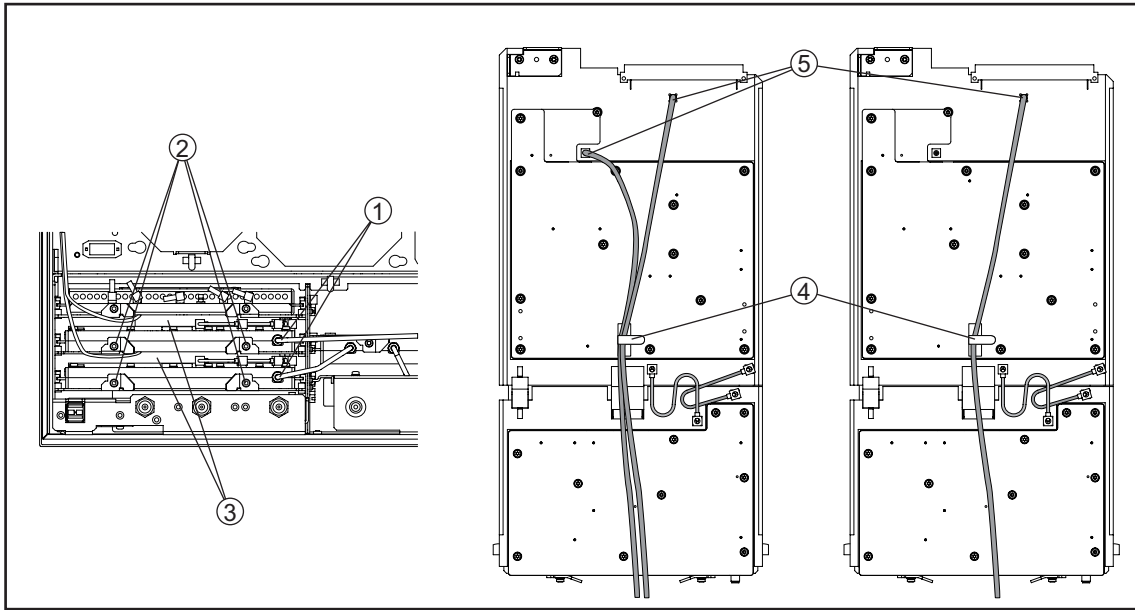

e5052bse1088

Replacement Procedure

Step 1. Replace the local synthesizer module by inverse procedure of removal.

NOTE

Fasten the semi-rigid cable using an open-end torque wrench for replacement.

A6 Phase Detector Board Replacement

Tools Required

- TORX screwdriver, T10, T15, and T20
- Flat edge screwdriver
- Open-end torque wrench, 5/16 inch (set to 1.02 N-m / 9.0 lb-in) (for reconnecting SMA connector)

Removal Procedure

- Step 1.** Remove the outer cover as described in “Outer Cover Removal” on page 140.
- Step 2.** Remove the front panel as described in “Front Panel Removal” on page 142.
- Step 3.** Release the clamped cables from the clamp (item 1).
- Step 4.** Disconnect the semi-rigid cables (item 2) from the phase detector board.
- Step 5.** Disconnect the RF cable (item 3) from the phase detector board.
- Step 6.** Remove two TORX T10 screws (item 4) from phase detector board.
- Step 7.** Slide out the phase detector board (item 5).
- Step 8.** Release the clamped cables from the clamp (item 6).
- Step 9.** Disconnect the cable (item 7) and remove a TORX T10 screw from the phase detector board.
- Step 10.** Disconnect the four RF cables (item 8) from the phase detector board.
- Step 11.** Disconnect the cable (item 9) from the phase detector board.

Refer to Figure 6-21 for this procedure.

Figure 6-21 A6 Phase Detector Board Removal

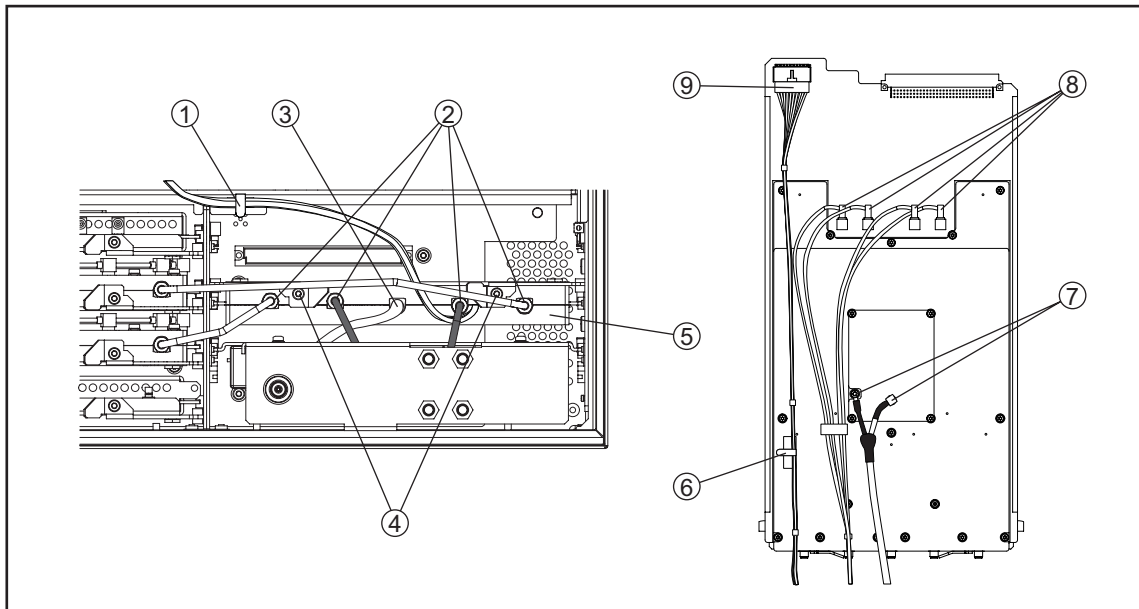

e5052bse1089

Replacement Procedure

Step 1. Replace the phase detector board by inverse procedure of removal.

NOTE

Fasten the semi-rigid cable using an open-end torque wrench for replacement.

A50 Analog Motherboard Replacement

Tools Required

- TORX screwdriver, T10, T15, and T20
- Flat edge screwdriver
- Open-end wrench, 9/16 inch (set to 3.39 N-m / 30.0 lb-in)
- Open-end torque wrench, 5/16 inch (set to 1.02 N-m / 9.0 lb-in) (for reconnecting SMA connector)

Removal Procedure

Refer to Figure 6-22 for this procedure.

- Step 1.** Remove the outer cover as described in “Outer Cover Removal” on page 140.
- Step 2.** Remove the front panel as described in “Front Panel Removal” on page 142.
- Step 3.** Remove the freq/power detector module as described in “A1 Freq / Power Detector Module Replacement” on page 172.
- Step 4.** Remove the ADC/DSP board as described in “A3 ADC/DSP Board Replacement” on page 176.
- Step 5.** Remove the local synthesizer module as described in “A4/A5 Local Synthesizer Module Replacement” on page 178.
- Step 6.** Remove the phase detector board as described in “A6 Phase Detector Board Replacement” on page 180.
- Step 7.** Remove the power supply as described in “Power Supply Assembly Replacement” on page 150.
- Step 8.** Remove the three 9/16 inch nuts (item 1) fastening the rear panel.
- Step 9.** Remove the four TORX T10 screws (item 2) from the chassis and remove the plate (item 3).
- Step 10.** Remove the ten TORX T10 screws (item 4) fastening the analog motherboard.
- Step 11.** Slide out the analog motherboard (item 5).

Figure 6-22 A50 Analog Motherboard Removal

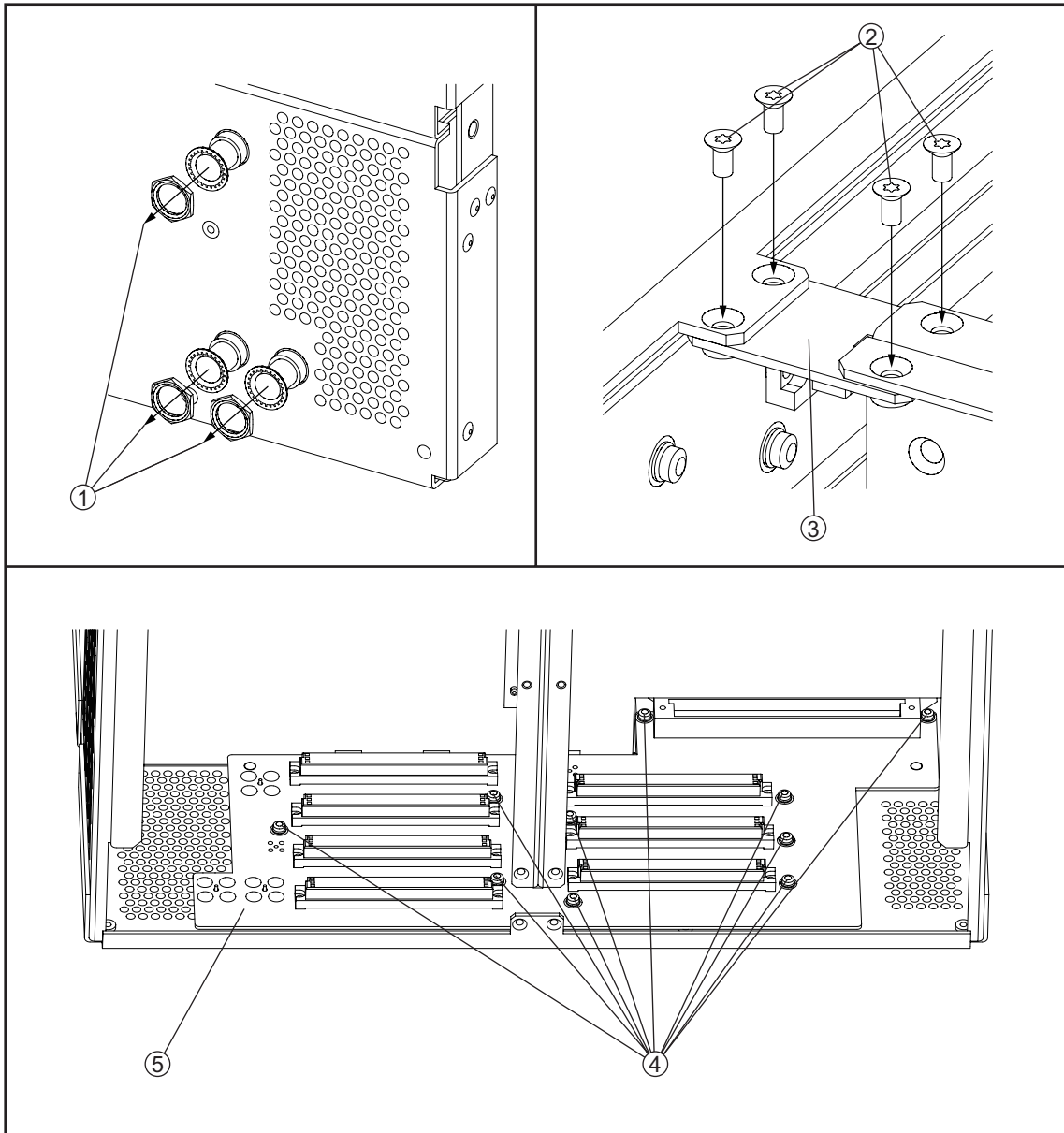

e5052bse1090

Replacement Procedure

Step 1. Replace the analog motherboard by inverse procedure of removal.

NOTE Fasten the 9/16 inch nut (item 1) using an open-end torque wrench for replacement.

Front Panel Cover Removal

Tools Required

- TORX screwdriver, T10, T15, and T20
- Flat edge screwdriver
- Open-end torque wrench, 5/16 inch (set to 1.02 N-m / 9.0 lb-in) (for reconnecting SMA connector)

Removal Procedure

Refer to Figure 6-23 for this procedure.

- Step 1.** Remove the outer cover as described in “Outer Cover Removal” on page 140.
- Step 2.** Remove the front panel as described in “Front Panel Removal” on page 142.
- Step 3.** Disconnect the cables (item 1, 2) connected through cover.
- Step 4.** Remove the seven TORX T10 screws (item 3) fastening the cover.

Figure 6-23 Front Panel Cover Removal

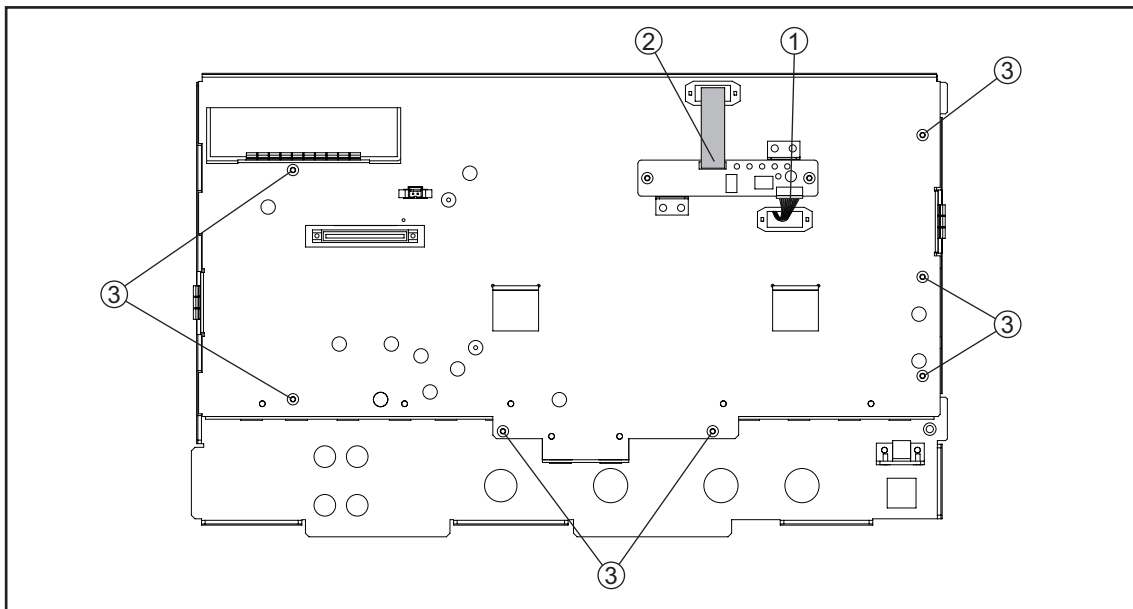

e5052bse1091

Control Touch Panel Replacement

Tools Required

- TORX screwdriver, T10, T15, and T20
- Flat edge screwdriver
- Open-end torque wrench, 5/16 inch (set to 1.02 N-m / 9.0 lb-in) (for reconnecting SMA connector)

Removal Procedure

Refer to Figure 6-24 for this procedure.

- Step 1.** Remove the outer cover as described in “Outer Cover Removal” on page 140.
- Step 2.** Remove the front panel as described in “Front Panel Removal” on page 142.
- Step 3.** Disconnect the cables (item 1, 2) connected through cover.
- Step 4.** Remove the two TORX T10 screws (item 3) fastening the control touch panel.

Figure 6-24 Control Touch Panel Removal

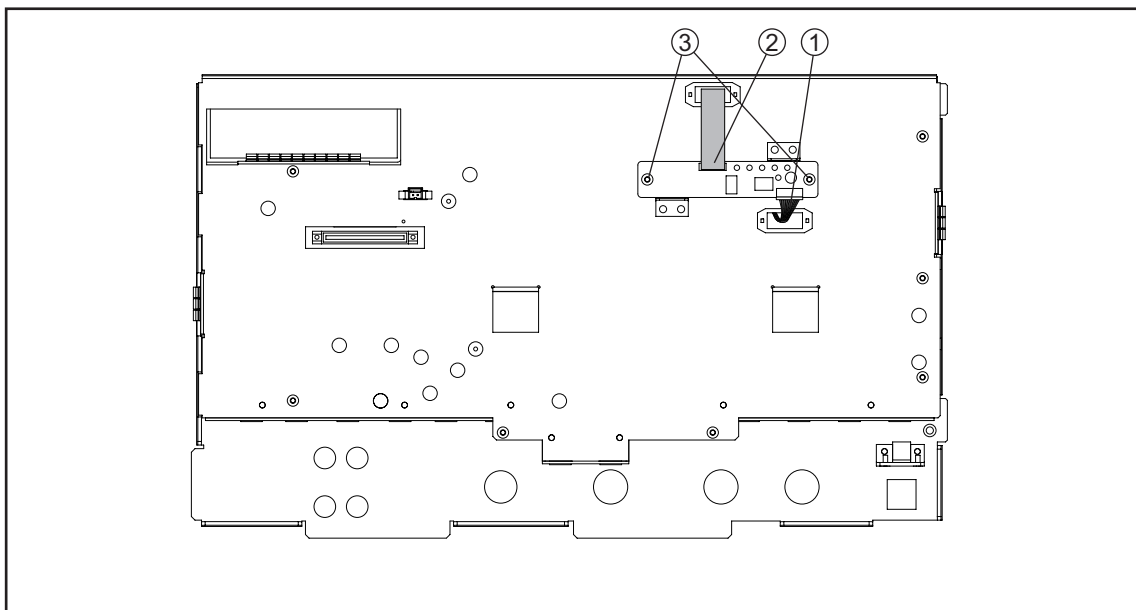

e5052bse1092

Replacement Procedure

- Step 1.** Replace the control touch panel by inverse procedure of removal.

A52 Inverter Assembly Replacement

Tools Required

- TORX screwdriver, T10, T15, and T20
- Open-end torque wrench, 5/16 inch (set to 1.02 N-m / 9.0 lb-in) (for reconnecting SMA connector)
- Flat edge screwdriver

Removal Procedure

Refer to Figure 6-25 for this procedure.

- Step 1.** Remove the outer cover as described in “Outer Cover Removal” on page 140.
- Step 2.** Remove the front panel as described in “Front Panel Removal” on page 142.
- Step 3.** Remove the front panel cover as described in “Front Panel Cover Removal” on page 184.
- Step 4.** Disconnect the three cables (item 1) connected front panel keyboard.

NOTE Be careful to remove the cables (item 1), and not apply any scratches on the cables.

- Step 5.** Remove the two TORX T15 screws (item 2) fastening the inverter assembly.
- Step 6.** Disconnect the two cables (item 3) connected the inverter assembly.

Figure 6-25 A52 Inverter Board Removal

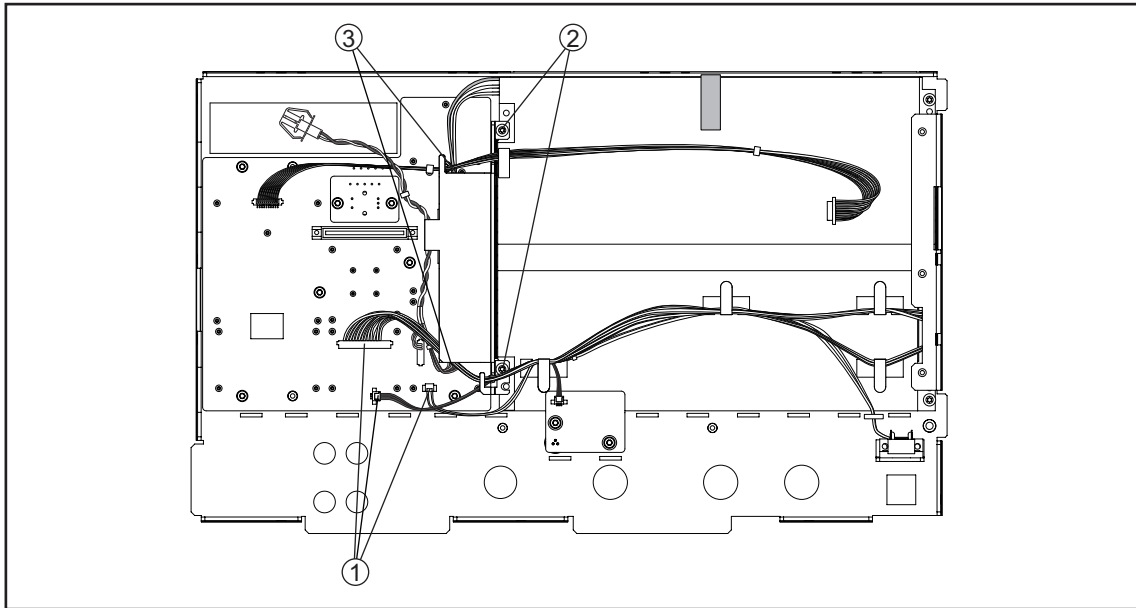

e5052bse1093

Replacement Procedure

Step 1. Replace the inverter assembly by inverse procedure of removal.

NOTE

Fasten the TORX T15 screws (item 2) using a torque screwdriver (set to 1.02 N-m / 9.0 lb-in).

A51 LCD Replacement

Tools Required

- TORX screwdriver, T10, T15, and T20
- Open-end torque wrench, 5/16 inch (set to 1.02 N-m / 9.0 lb-in) (for reconnecting SMA connector)
- Flat edge screwdriver

Removal Procedure

Refer to Figure 6-26 for this procedure.

- Step 1.** Remove the outer cover as described in “Outer Cover Removal” on page 140.
- Step 2.** Remove the front panel as described in “Front Panel Removal” on page 142.
- Step 3.** Remove the front panel cover as described in “Front Panel Cover Removal” on page 184.
- Step 4.** Remove the inverter assembly as described in “A52 Inverter Assembly Replacement” on page 186.
- Step 5.** Release the clamped cables from the clamps (item 1) on the LCD.
- Step 6.** Disconnect the cable (item 2) from the probe power.
- Step 7.** Remove the two TORX T10 screws (item 3) fastening the probe power and lift it (item 4).
- Step 8.** Remove the two TORX T15 screws (item 5) fastening the LCD to the front panel.
- Step 9.** Disconnect the cable (item 6) from the LCD.

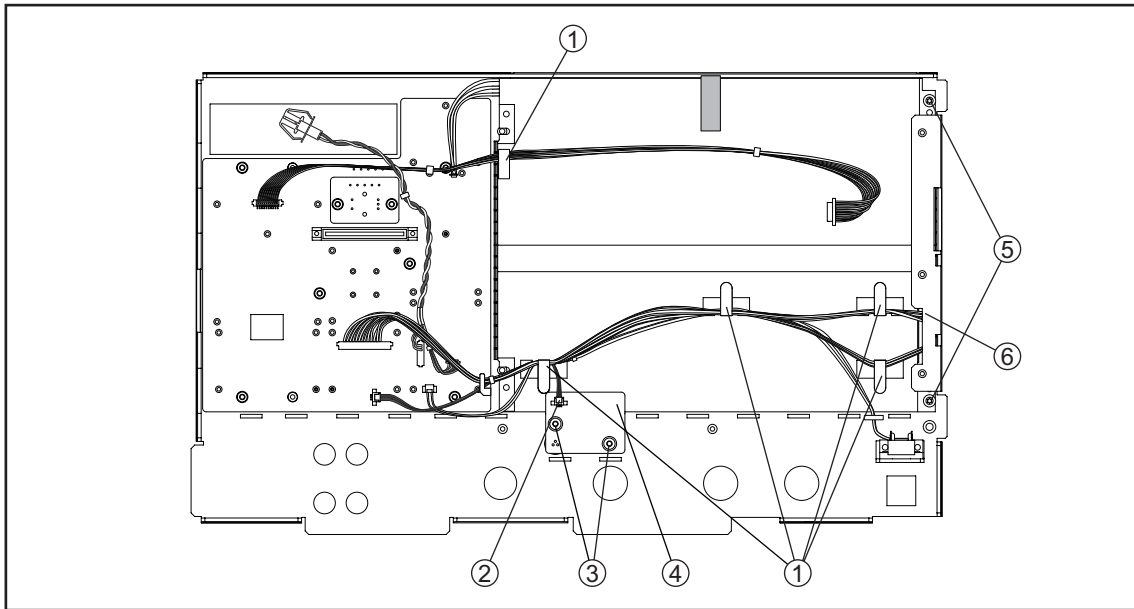
Figure 6-26 **A51 LCD Removal**

e5052bse1094

Replacement Procedure

Step 1. Replace the LCD by inverse procedure of removal.

NOTE

Fasten the TORX T15 screws (item 5) using a torque screwdriver (set to 1.02 N-m / 9.0 lb-in).

Step 2. You have to calibrate the touch screen. Follow the procedure described on “Calibration of the Touch Screen” on page 231.

A22 Front Keyboard Replacement

Tools Required

- TORX screwdriver, T10, T15, and T20
- Flat edge screwdriver
- Open-end torque wrench, 5/16 inch (set to 1.02 N-m / 9.0 lb-in) (for reconnecting SMA connector)
- Hex key, 1.5 mm

Removal Procedure

Refer to Figure 6-27 for this procedure.

- Step 1.** Remove the outer cover as described in “Outer Cover Removal” on page 140.
- Step 2.** Remove the front panel as described in “Front Panel Removal” on page 142.
- Step 3.** Remove the front panel cover as described in “Front Panel Cover Removal” on page 184.
- Step 4.** Remove the inverter assembly as described in “A52 Inverter Assembly Replacement” on page 186.
- Step 5.** Remove the knob (item 1) from switch rotary using the hex key.
- Step 6.** Disconnect the all cables (item 2) from the front panel keyboard.
- Step 7.** Remove the eight TORX T10 screws (item 3) fastening the front panel keyboard.
- Step 8.** Remove the keyboard rubber from the front panel keyboard.

Figure 6-27 A22 Front Keyboard Removal

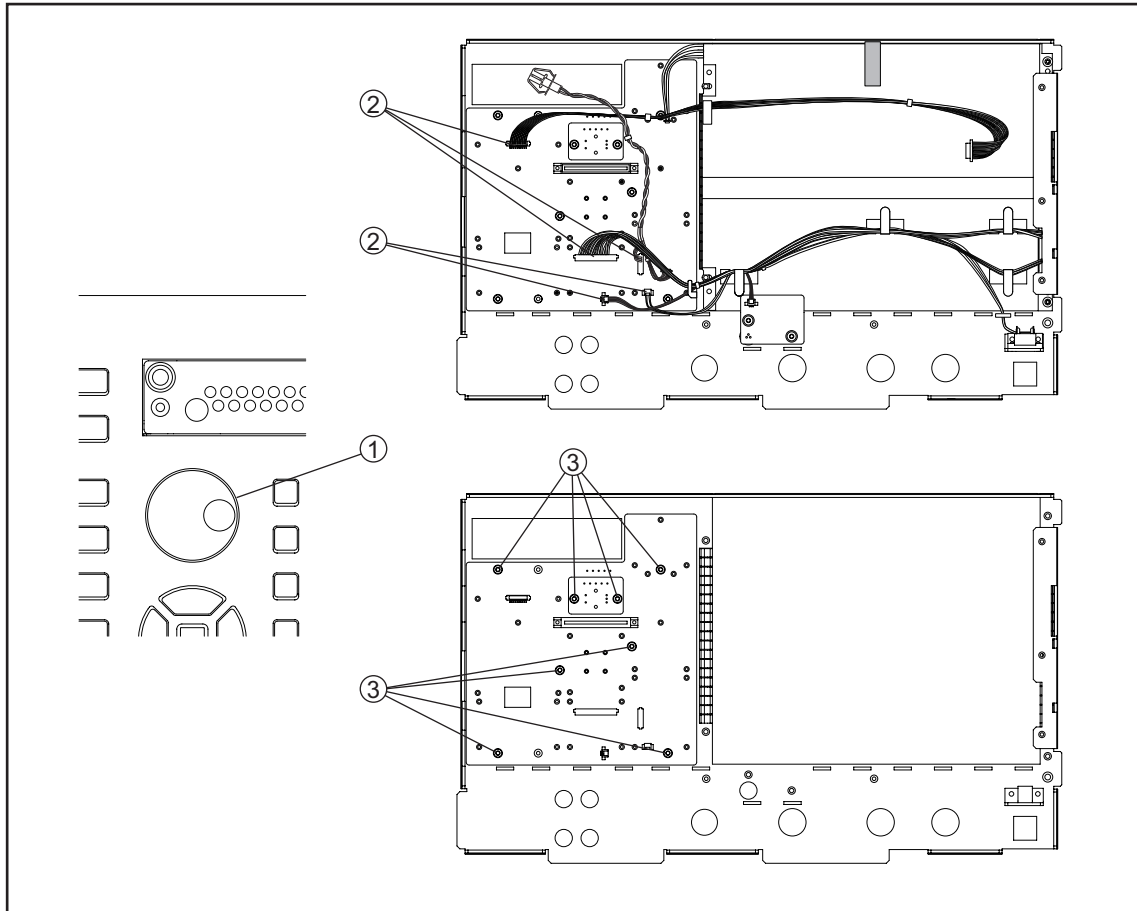

e5052bse1095

Replacement Procedure

- Step 1.** Insert the whole jut of the rubber key into the hole on the new front panel keyboard.
- Step 2.** Replace the front panel keyboard by inverse procedure of removal.

NOTE

Replace the keyboard rubber to new one, if it's pulled the keyboard rubber from the front panel keyboard.

Front USB PCA Board Replacement

Tools Required

- TORX screwdriver, T10, T15, and T20
- Open-end torque wrench, 5/16 inch (set to 1.02 N-m / 9.0 lb-in) (for reconnecting SMA connector)
- Flat edge screwdriver

Removal Procedure

Refer to Figure 6-28 for this procedure.

- Step 1.** Remove the outer cover as described in “Outer Cover Removal” on page 140.
- Step 2.** Remove the front panel as described in “Front Panel Removal” on page 142.
- Step 3.** Remove the three TORX T15 screws (item 1).
- Step 4.** Disconnect the USB cables (item 2) from the front USB PCA.
- Step 5.** Remove the two TORX T10 screws (item 3) fastening the bracket BNC.

Figure 6-28 Front USB PCA Board Removal

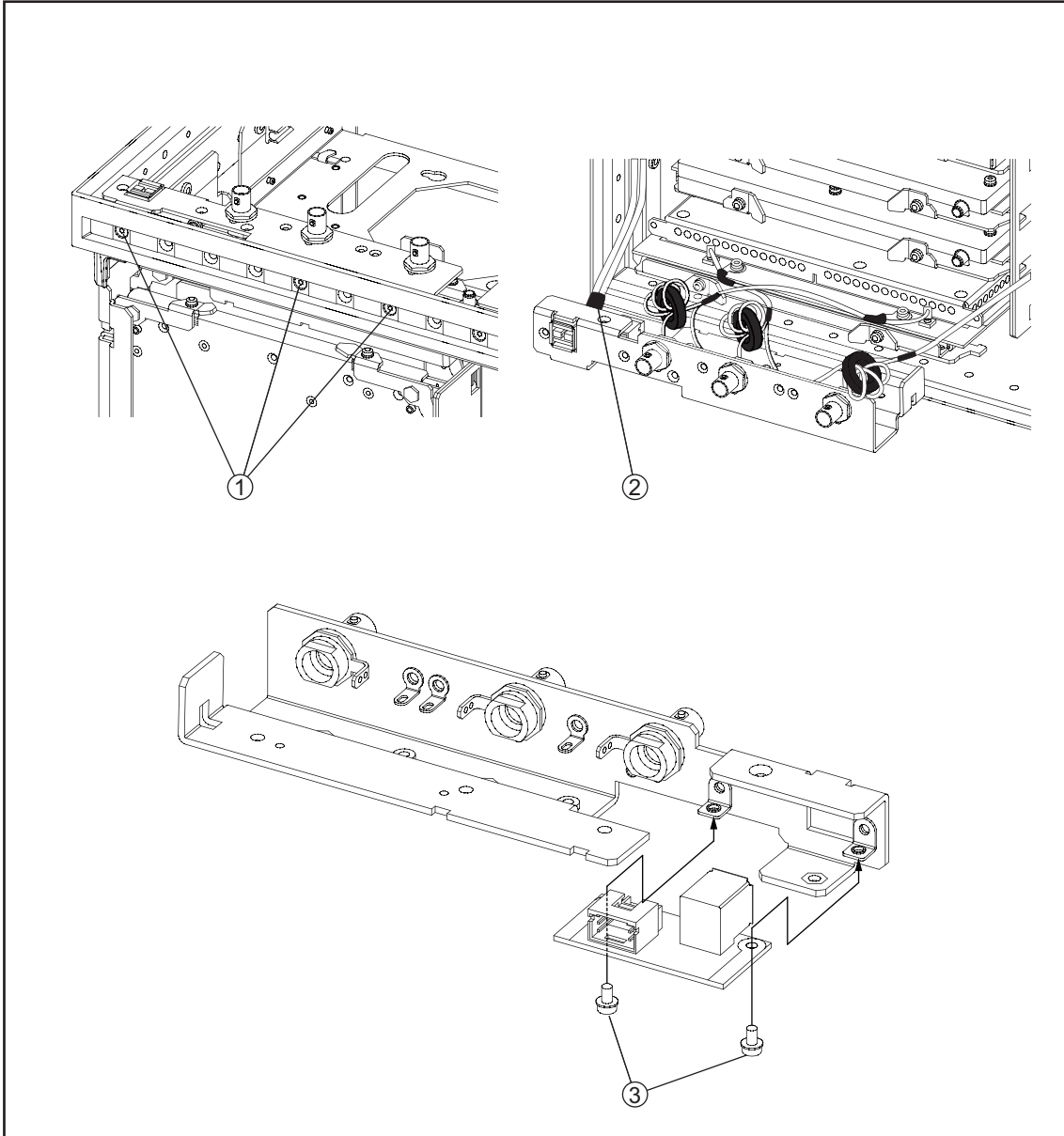

e5052bse1096

Replacement Procedure

Step 1. Replace the front USB PCA by inverse procedure of removal.

Probe Power and Power Switch Board Replacement

Tools Required

- TORX screwdriver, T8, T10, T15, and T20
- Flat edge screwdriver
- Open-end torque wrench, 5/16 inch (set to 1.02 N-m / 9.0 lb-in) (for reconnecting SMA connector)
- Hex key, 1.5 mm

Removal Procedure

Refer to Figure 6-29 for this procedure.

- Step 1.** Remove the outer cover as described in “Outer Cover Removal” on page 140.
- Step 2.** Remove the front panel as described in “Front Panel Removal” on page 142.
- Step 3.** Remove the front panel cover as described in “Front Panel Cover Removal” on page 184.
- Step 4.** Remove the Probe Power Board or Switche Board.

For removing the Prove Power Board.

- Disconnect the cable (item 1) from the front panel keyboard.
- Remove the two TORX T10 screws (item 2) fastening the front panel.

For removint the Switche Board.

- Disconnect the cable (item 3) connected the front panel keyboard.
- Release the clamped cables from the clamps (item 4) on the LCD.
- Cut the cable tie (item 5).
- Remove the two TORX T8 screws (item 6) fastening the angle.

Figure 6-29 Probe Power and Power Switch Board Removal

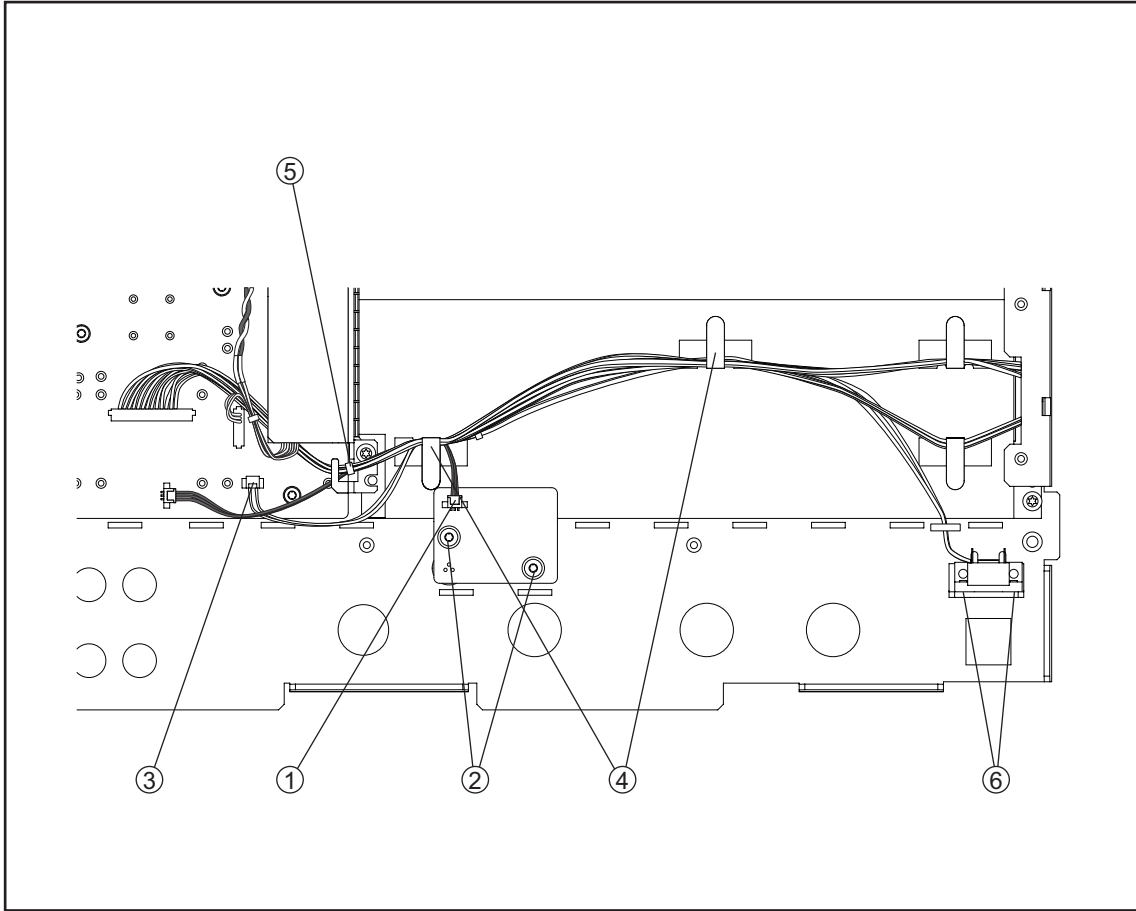

e5052bse1097

Replacement Procedure

Step 1. Replace the prove power board or switch board by inverse procedure of removal.

Front BNC Connector Replacement

Tools Required

- TORX screwdriver, T10, T15, and T20
- Flat edge screwdriver
- Cutting plier
- Open-end wrench, 9/16 inch (set to 3.39 N-m / 30.0 lb-in)
- Open-end torque wrench, 5/16 inch (set to 1.02 N-m / 9.0 lb-in) (for reconnecting SMA connector)

Removal Procedure

Refer to Figure 6-30 for this procedure.

- Step 1.** Remove the outer cover as described in “Outer Cover Removal” on page 140.
- Step 2.** Remove the front panel as described in “Front Panel Removal” on page 142.
- Step 3.** Remove the DC Source board as described in “A2 DC Source Board Replacement” on page 174.
- Step 4.** Cut the cable tie (item 1) which ties cable.
- Step 5.** Remove the two TORX T10 screws (item 2) fastening the bracket BNC.
- Step 6.** Remove the three cable assembly (item 3) fastening the bracket BNC.
- Step 7.** If the diode is to be replaced, unsolder the diode (item 4).
- Step 8.** Remove a 9/16 inch nut (item 5) fastening the angle.
- Step 9.** Remove the three RF connector (item 6) fastening the angle.

Figure 6-30 Front BNC Connector Removal

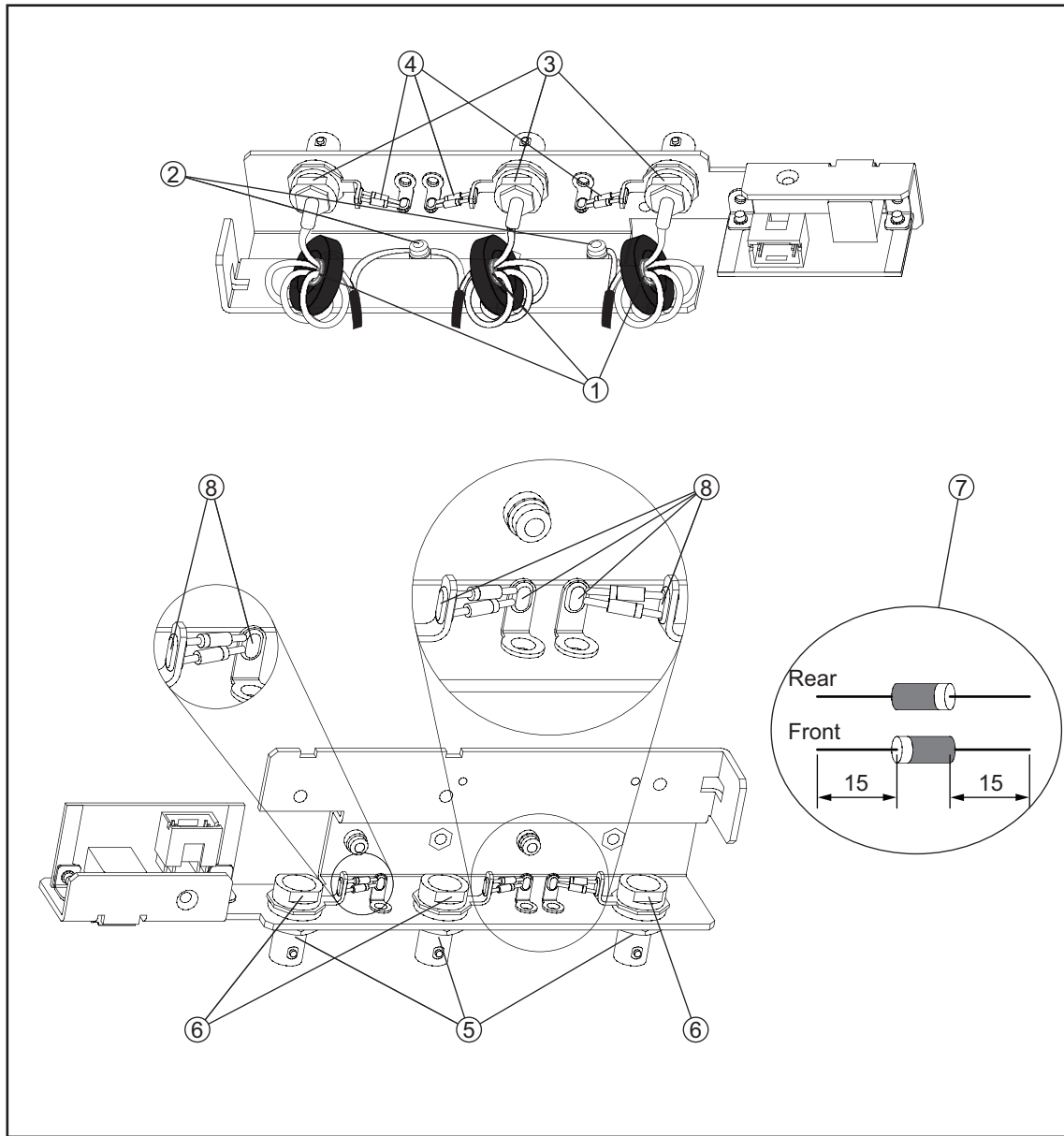

e5052bse1098

Replacement Procedure

- Step 1.** When the diode is replaced, cut the new diode leads as show in the figure (item 7).
Solder the new diode as show in the figure (item 8).

NOTE Ensure that the polarity of the diode is correct.

- Step 2.** Replace the front BNC connector by inverse procedure of removal.

Replacement Procedure
Front BNC Connector Replacement

NOTE Fasten the 9/16 inch nut (item 5) using a open-end torque wrench for replacement.

7**Post-Repair Procedures**

This chapter lists the procedures required to verify the E5052B operation after an assembly is replaced with a new one.

Post-Repair Procedures

Table 7-1 *Post Repair Procedures* lists the required procedures that must be performed after the replacement of an assembly. These are the recommended minimum procedures to ensure that the replacement is successfully completed.

Table 7-1 Post-Repair Procedures

Replaced Assembly or Part	Required Adjustments Correction Constants (CC)	Verification
A1 Freq/Power Detector module	Perform the following required adjustments using “A1 Freq/Power Det.” in Spot Adjustment of the program. Reference Frequency Adjustment Pre-LO Sampler PLL BW Adjustment Receiver DC offset Adjustment PM Offset Adjustment PM Linearity Adjustment PM Temp Adjustment PM Flatness Adjustment Receiver RF Flatness Adjustment Receiver IF Gain/Flatness Adjustment Receiver RF Flatness Dir Adjustment Receiver IF Gain/Flatness Dir Adjustment LO Sampler PLL BW Adjustment Phase Noise BW Adjustment FLL BW Adjustment	“Power On Test” on page 70 RF IN Port VSWR Test Frequency Measurement Test Power Measurement Accuracy Test Phase Noise Accuracy Test SSB Phase Noise Sensitivity Test SA Relative Level Accuracy Test
A2 DC Source Board	Perform the following required adjustments using “A2 DC Source” in Spot Adjustment of the program. DC Control Voltage Adjustment DC Power Voltage Adjustment DC Power Current Adjustment	“Power On Test” on page 70 DC Power Voltage Test DC Power Current Measurement Test

Table 7-1 Post-Repair Procedures

Replaced Assembly or Part	Required Adjustments Correction Constants (CC)	Verification
A3 ADC/DSP Board	Perform the following required adjustments using “A3 ADC/DSP” in Spot Adjustment of the program. Reference Frequency Adjustment Pre-LO Sampler PLL BW Adjustment Receiver DC offset Adjustment Receiver RF Flatness Adjustment Receiver IF Gain/Flatness Adjustment Receiver RF Flatness Dir Adjustment Receiver IF Gain/Flatness Dir Adjustment LO Sampler PLL BW Adjustment Phase Noise BW Adjustment FLL BW Adjustment	“Power On Test” on page 70 RF IN Port VSWR Test Frequency Measurement Test Power Measurement Accuracy Test Phase Noise Accuracy Test SSB Phase Noise Sensitivity Test SA Relative Level Accuracy Test
A4/A5 Local Synthesize module	Perform the following required adjustments using “A4/A5 Local Synt” in Spot Adjustment of the program. Reference Frequency Adjustment Pre-LO Sampler PLL BW Adjustment Receiver DC offset Adjustment Receiver RF Flatness Adjustment Receiver IF Gain/Flatness Adjustment Receiver RF Flatness Dir Adjustment Receiver IF Gain/Flatness Dir Adjustment LO Sampler PLL BW Adjustment Phase Noise BW Adjustment FLL BW Adjustment	“Power On Test” on page 70 RF IN Port VSWR Test Frequency Measurement Test Power Measurement Accuracy Test Phase Noise Accuracy Test SSB Phase Noise Sensitivity Test SA Relative Level Accuracy Test
A6 Phase Detector Board	Perform the following required adjustments using “A6 Phase Det” in Spot Adjustment of the program. Reference Frequency Adjustment Pre-LO Sampler PLL BW Adjustment Receiver DC offset Adjustment Receiver RF Flatness Adjustment Receiver IF Gain/Flatness Adjustment Receiver RF Flatness Dir Adjustment Receiver IF Gain/Flatness Dir Adjustment LO Sampler PLL BW Adjustment Phase Noise BW Adjustment FLL BW Adjustment	“Power On Test” on page 70 RF IN Port VSWR Test Frequency Measurement Test Power Measurement Accuracy Test Phase Noise Accuracy Test SSB Phase Noise Sensitivity Test SA Relative Level Accuracy Test
Oven Ch1	No adjustment needed	“To Check the Oven Ch1” on page 81
Oven Ch2	No adjustment needed	“To Check the Oven Ch2” on page 82

Post-Repair Procedures
Post-Repair Procedures

Table 7-1 Post-Repair Procedures

Replaced Assembly or Part	Required Adjustments Correction Constants (CC)	Verification
A22Power Distribution Board	No adjustment needed	Inspect the Booting Process “Power On Test” on page 70
A50 Analog Motherboard	No adjustment needed	Inspect the Booting Process When the symptom of failure is out of specification, perform the performance test.
A20 Digital Motherboard	Set jumpers and BIOS parameters on the A20. For details, see “To configure the A20 Digital Motherboard and BIOS” on page 87.	Inspect the Booting Process
A21 PCI DSP Card	Perform the following required adjustments using “PCI DSP Card” in Spot Adjustment of the program. Writing ID	Inspect the Booting Process “To Check the Front Panel” on page 78 “To Check the External Trigger Input” on page 80
A22 Front Panel Keyboard	No adjustment needed	“To Check the Front Panel” on page 78
A24 GPIB Board	No adjustment needed	“To Check the GPIB” on page 81
USB (USBTMC) Interface Card	No adjustment needed	“To Check the USB (USBTMC) Interface Card” on page 82
A23 24-bit I/O Board	No adjustment needed	“To Check the 24-bit I/O port” on page 81
A27 Removable Hard Disk Drive	Perform “HDD” (Hard Disk Drive) in Spot Adjustment of the program. DC Control Voltage Adjustment DC Power Voltage Adjustment DC Power Current Adjustment Reference Frequency Adjustment Pre-LO Sampler PLL BW Adjustment Receiver DC offset Adjustment PM Offset Adjustment PM Linearity Adjustment PM Temp Adjustment PM Flatness Adjustment Receiver RF Flatness Adjustment Receiver IF Gain/Flatness Adjustment Receiver RF Flatness Dir Adjustment Receiver IF Gain/Flatness Dir Adjustment LO Sampler PLL BW Adjustment Phase Noise BW Adjustment FLL BW Adjustment	Inspect the Booting Process RF IN Port VSWR Test Frequency Measurement Test Power Measurement Accuracy Test Phase Noise Accuracy Test SSB Phase Noise Sensitivity Test SA Relative Level Accuracy Test DC Power Voltage Test DC Power Current Measurement Test

Table 7-1 Post-Repair Procedures

Replaced Assembly or Part	Required Adjustments Correction Constants (CC)	Verification
Power Supply Assembly	No adjustment needed	Inspect the Booting Process
A51 LCD	Calibration of the Touch Screen	Inspect the Booting Process “To Check the LCD” on page 79
A52 Inverter Board	No adjustment needed	Inspect the Booting Process

Post-Repair Procedures
Post-Repair Procedures

A **Manual Changes**

This appendix contains the information required to adapt this manual to versions or configurations of the E5052B manufactured earlier than the current printing date of this manual. The information in this manual applies directly to the E5052B units with the serial number that is printed on the title page of this manual.

Manual Changes

To adapt this manual to your E5052B, refer to Table A-1 and Table A-2.

Table A-1 **Manual Changes by Serial Number**

Serial Prefix or Number	Make Manual Changes

Table A-2 **Manual Changes by Firmware Version**

Version	Make Manual Changes

The ten-character serial number is stamped on the serial number plate (Figure A-1) on the rear panel.

Figure A-1 **Serial Number Plate Example**



e5052bse1001

B System Recovery

This appendix describes how to recover the operating system (Windows XP) when the operating system has been damaged.

System Recovery

By executing system recovery, you can return the system of the E5052B (the Windows operating system and the firmware) to the factory state (at the time of purchase *1).

CAUTION

Strictly follow the steps described below. If you do any operation other than the following steps, the system may not be recovered.

Types of system recoveries

The following 2 types of system recoveries are available.

- Factory recovery
 - Returns the contents of the C drive to the factory state.
- User recovery
 - Returns the contents of the C and F drives to a user-specified state. To use this function, you must prepare for recovery in advance. For information on the preparation, see “Procedure to create the user backup image” on page 212 for information on the execution, see “Procedure to execute the user recovery function” on page 218.

Notes on executing the factory recovery function

Executing the factory recovery function causes the following:

- In addition to the Windows operating system and the firmware, the following settings of the E5052B are returned to the factory state or a user specified state.
 - Network setting
 - GPIB setting
 - Printer setting
- The driver for the supported printer installed after purchase is deleted.
- You need to execute initial registration again.

Files you created using the save function (files in the F drive) are not affected, but we recommend backing them up before executing system recovery for precautionary purposes. For more information on backup, refer to “Backing Up the Data” as described in E5052B Online Help.

*1. If the hard disk failed and has been replaced after purchase, the state when the replacement was performed is recovered.

Procedure to execute the factory recovery

This section describes how to return the contents of the C drive to the factory state.

NOTE You need the keyboard and mouse for this operation.

- Step 1.** Shut down the E5052B.
- Step 2.** Disconnect all of the USB device from the USB ports.
- Step 3.** Connect the keyboard to the E5052B.
- Step 4.** Press the standby switch of the E5052B to turn it on.
- Step 5.** When the screen as shown in the figure below appears, press F11 of the keyboard.

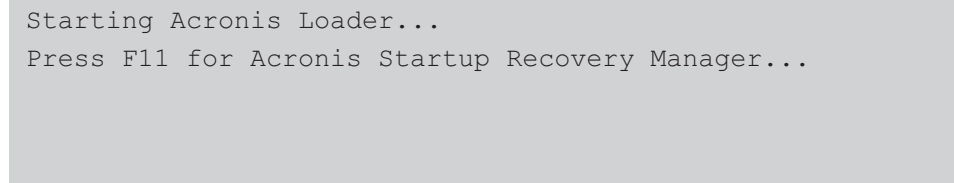

```
Starting Acronis Loader...  
Press F11 for Acronis Startup Recovery Manager...
```

e5071cse1055

CAUTION Press F11 only once. If you press F11 twice or more and a screen which is not mentioned in this manual appears, reboot the instrument and restart the process from the first.

NOTE After several seconds, the next screen appears automatically even if you do not press any key, so do not miss it.

NOTE After Step 5, if the E5052B freezes with the cursor blinks, turn the power off and remove unnecessary USB devices. Then, replace the keyboard with a PS/2 keyboard to execute the process again.

System Recovery System Recovery

Step 6. Select **Restore**.

Figure B-1 **Activate Acronis Startup Recovery Manager**

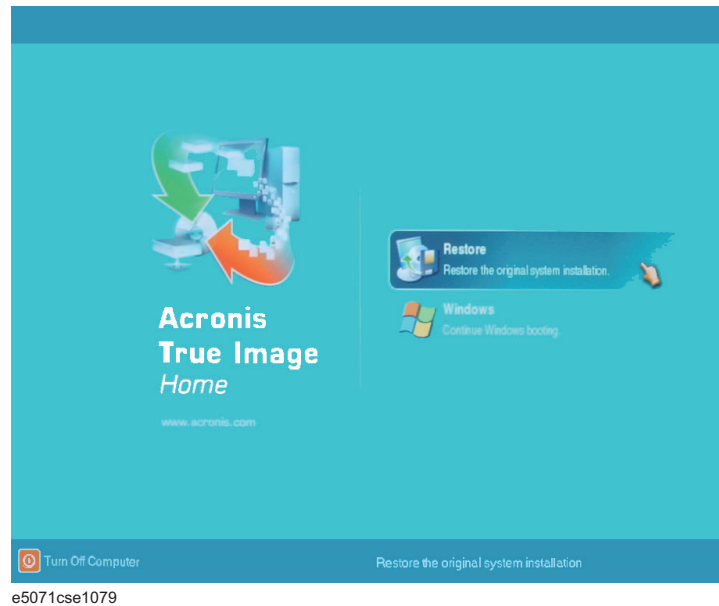

Step 7. A confirmation dialog box is displayed. Push the enter to select **Yes** to start the recovery of the factory backup. The recovery takes a few minutes depending on the amount of data.

Figure B-2 **Recover Factory Backup**

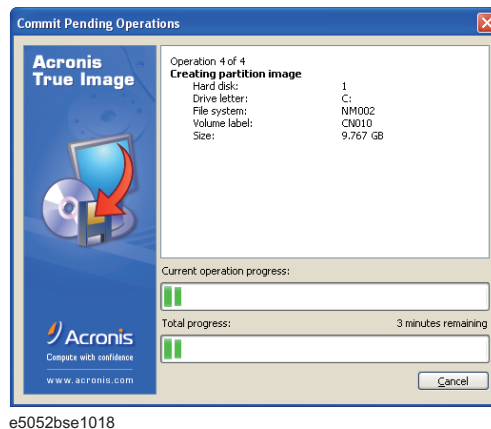

Step 8. When the recovery is finished, push the enter select OK. The E5052B restarts automatically.

Step 9. After restart, the screen for initial registration appears. Execute initial registration. For information on the execution procedure, refer to “Initial Registration of E5052B” on page 229.

Step 10. Execute the calibration of the touch screen. For information on the execution procedure, refer to “Calibration of the Touch Screen” on page 231.

CAUTION

Never turn off the power during the system recovery because doing so may cause serious damage to the E5052B.

Procedure to create the user backup image

This section describes how to create the user backup image. The C and F drives' contents saved in this procedure are recalled when the user recovery function is executed.

- Step 1.** Close the E5052B application by pressing **System** > Service Menu > Exit.
- Step 2.** Close all other applications you currently open.
- Step 3.** From the Windows start menu, select All Programs > Acronis > Acronis True Image.
- Step 4.** Click “No, Thanks” button.

Figure B-3

Recover Factory Backup

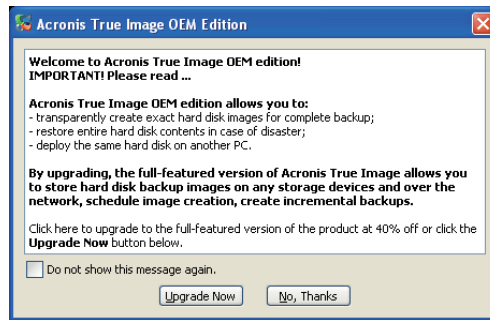

e5071cse1080

- Step 5.** Click **Backup**.

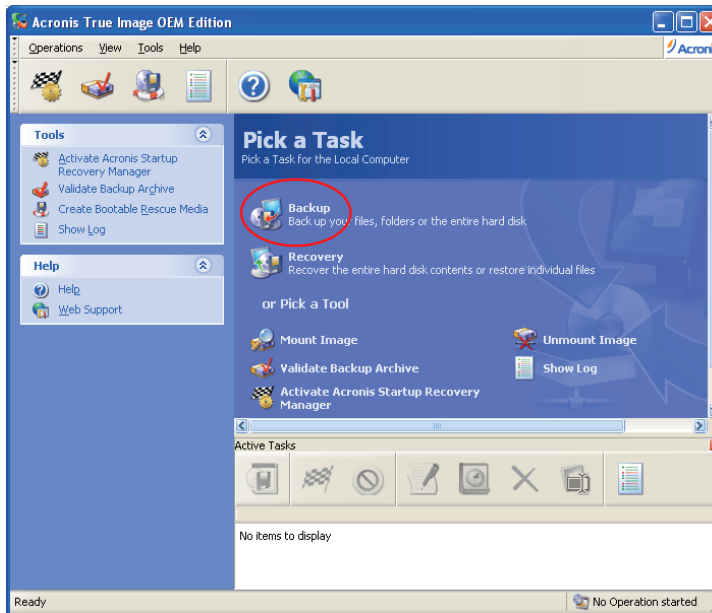

e5071cse1125

Step 6. Click **Next** button.

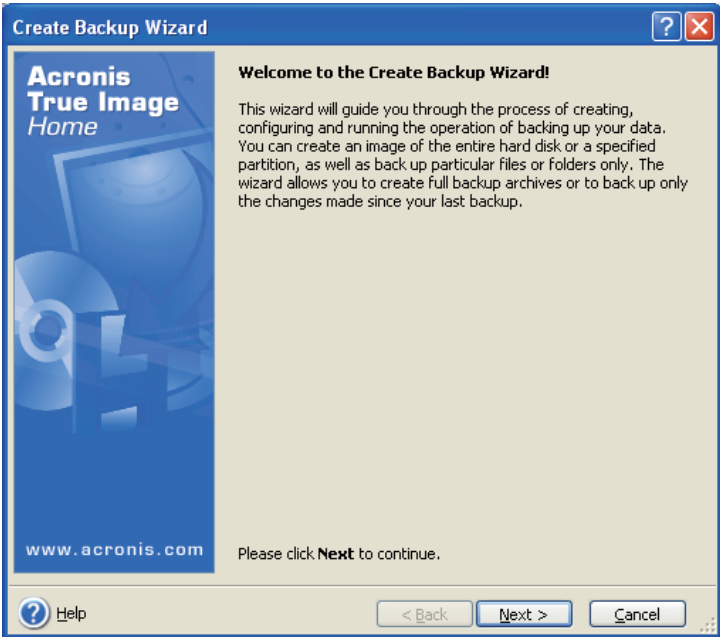

e5071cse1126

Step 7. Select “The entire disk contents or individual partition,” then click **Next** button.

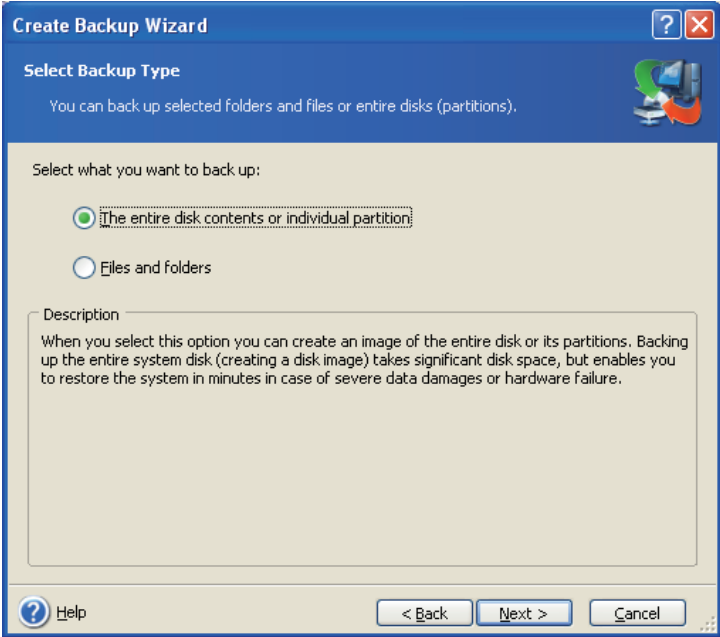

e5071cse1127

B. System Recovery

System Recovery System Recovery

Step 8. Select the C drive and F drive.

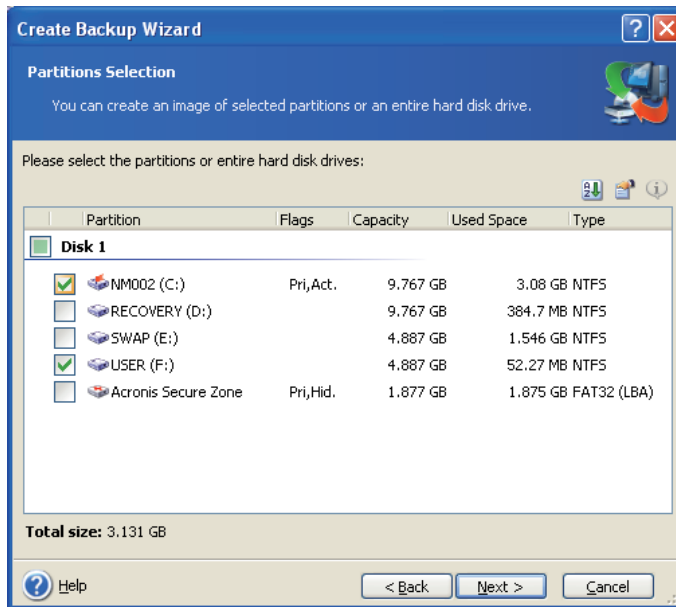

e5052bse1019

Step 9. Select the destination folder and input a file name, then click **Next** button. It is recommended to save the file to a directory which has enough space like the D drive. Also, never save the contents of the drive to the C, E or F drive.

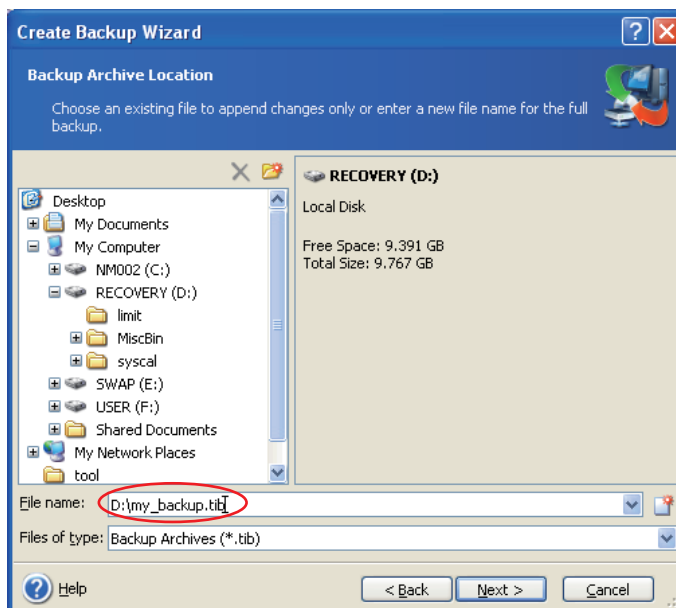

e5052bse1020

Step 10. Select “Set the options manually” and click **Next** button.

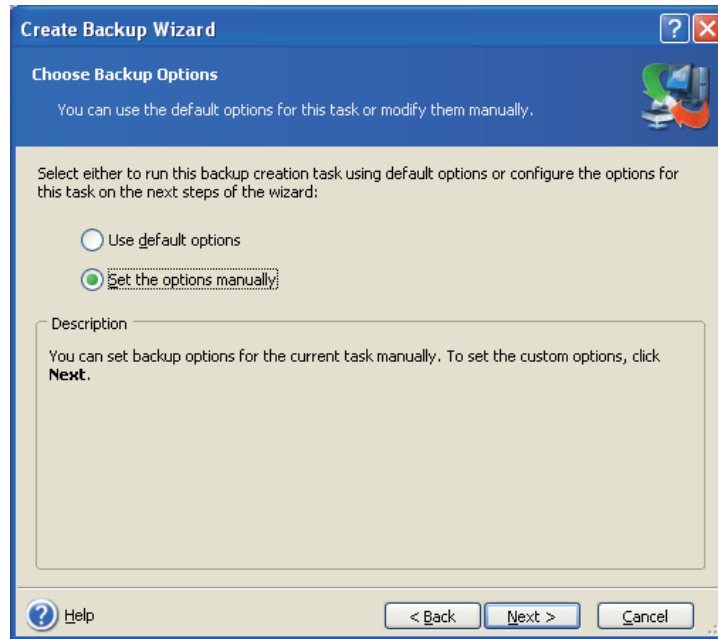

e5071cse1130

Step 11. Select “Backup priority” in the left field and “High” in the right field, then click **Next** button.

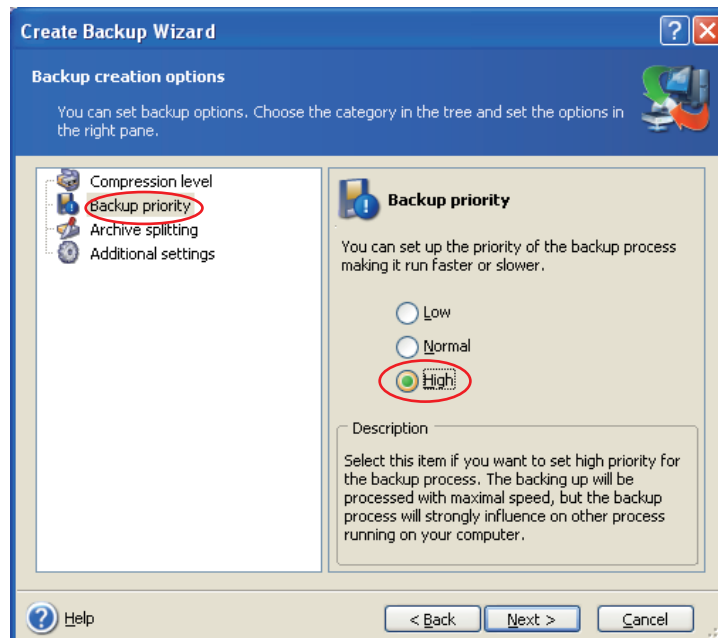

e5071cse1131

System Recovery

System Recovery

Step 12. If necessary, input comments and click **Next** button. The comments can be omitted.

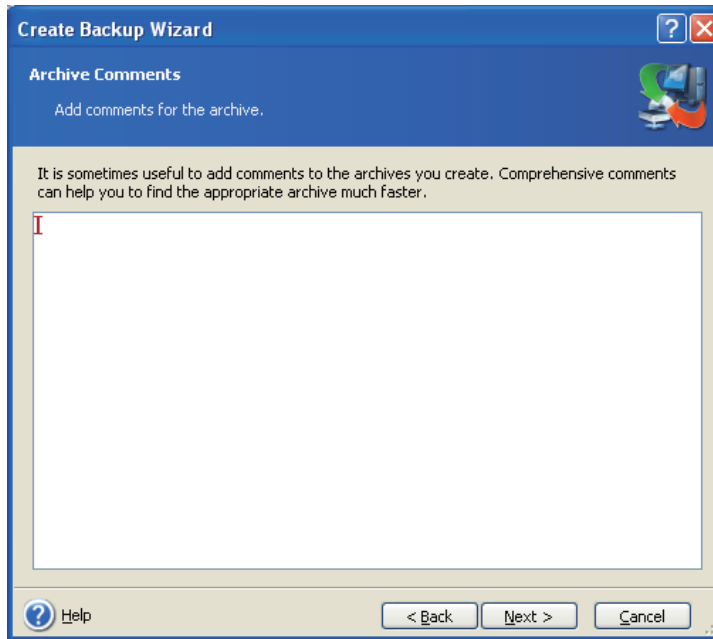

e5071cse1132

Step 13. Click **Proceed** button.

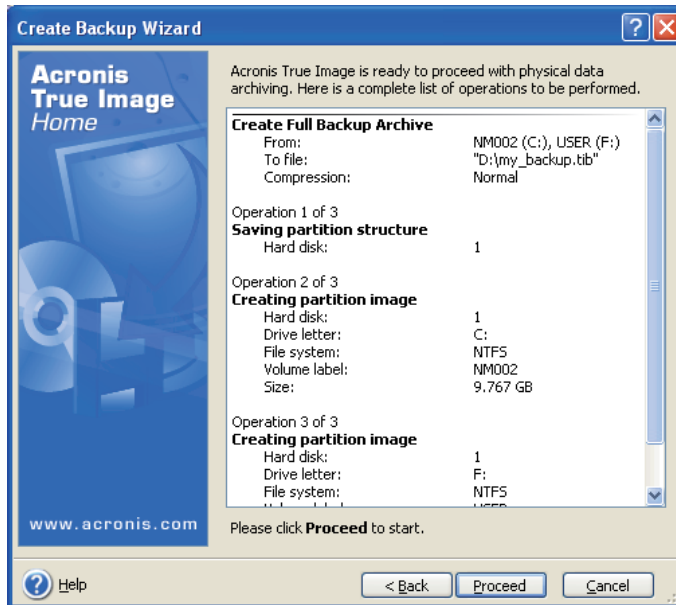

e5052bse1021

Step 14. The following screen appears during backup.

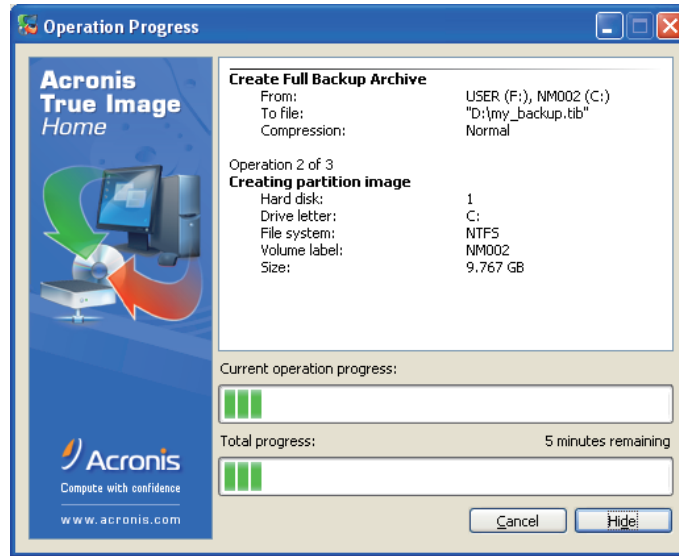

e5052bse1022

Step 15. The following screen appears when the user backup image was created. Click **OK**.

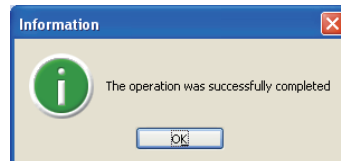

e5052bse1023

CAUTION

Never turn off the power during creating the user backup image because doing so may cause serious damage to the E5052B.

System Recovery

System Recovery

Procedure to execute the user recovery function

Returns the contents of the C and F drives to a user-specified state. To use this function, you must create the user backup image in advance. For more information, see the description “Procedure to create the user backup image” on page 212.

- Step 1.** Close the E5052B application by pressing **System** > Service Menu > Administrator Menu > Exit E5052B > OK.
- Step 2.** Close all other applications you currently open.
- Step 3.** From the Windows start menu, select All Programs > Acronis > Acronis True Image.
- Step 4.** Click “No, Thanks” button.

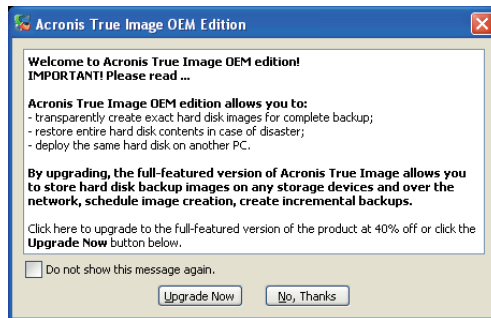

e5071cse1080

- Step 5.** Click **Recovery**.

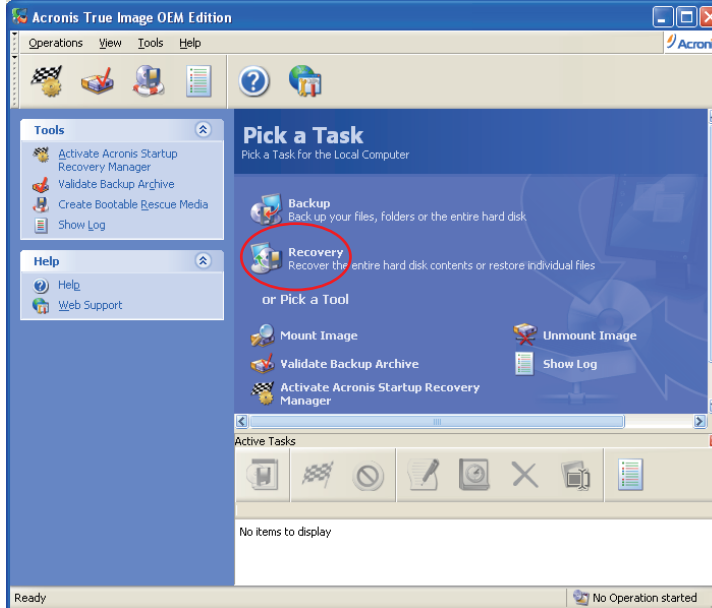

e5071cse1136

Step 6. Click **Next** button.

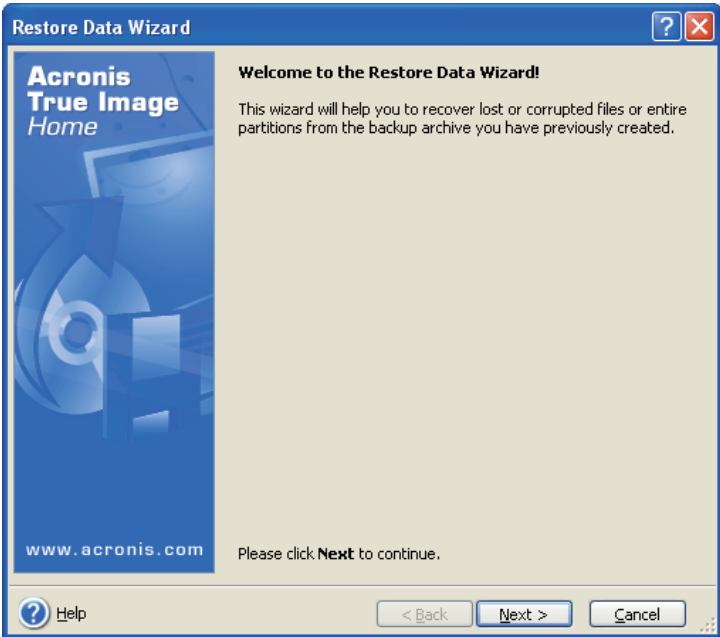

e5071cse1137

Step 7. Select the saved backup image file, then click **Next** button.

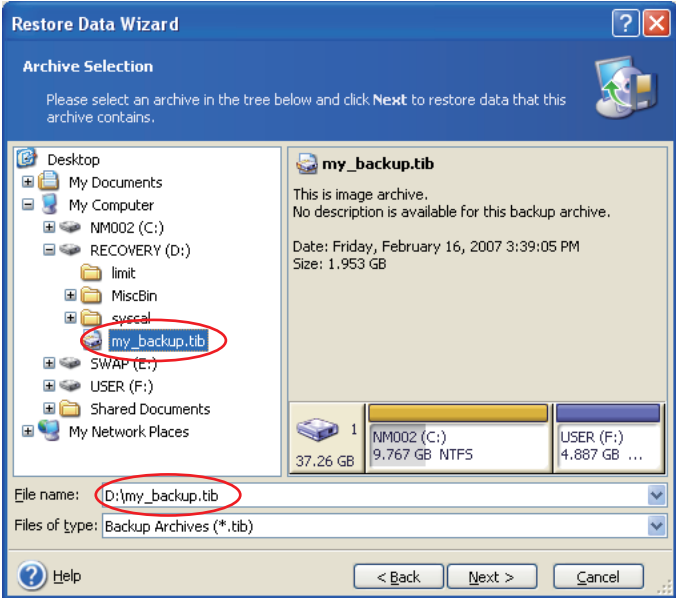

e5052bse1024

B. System Recovery

System Recovery System Recovery

Step 8. Select “Restore disks or partitions,” then click **Next** button.

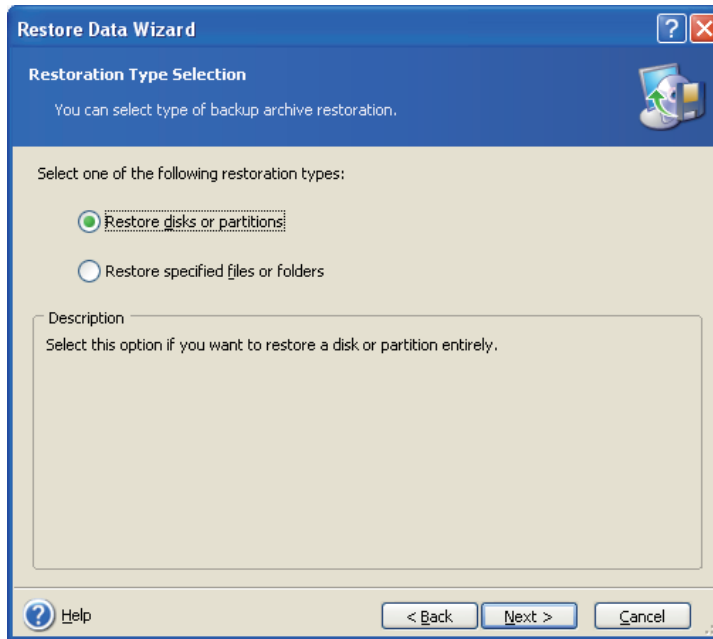

e5071cse1139

Step 9. Select the C drive, then click **Next** button.

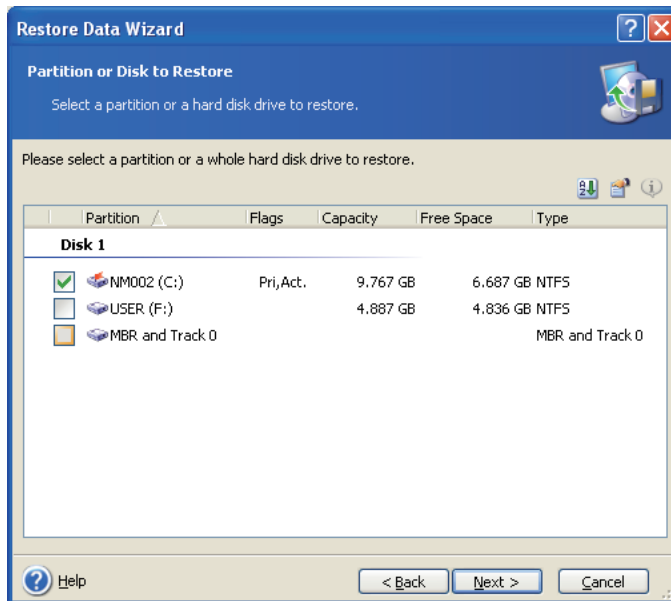

e5052bse1025

Step 10. Select the C drive to restore, then click **Next** button.

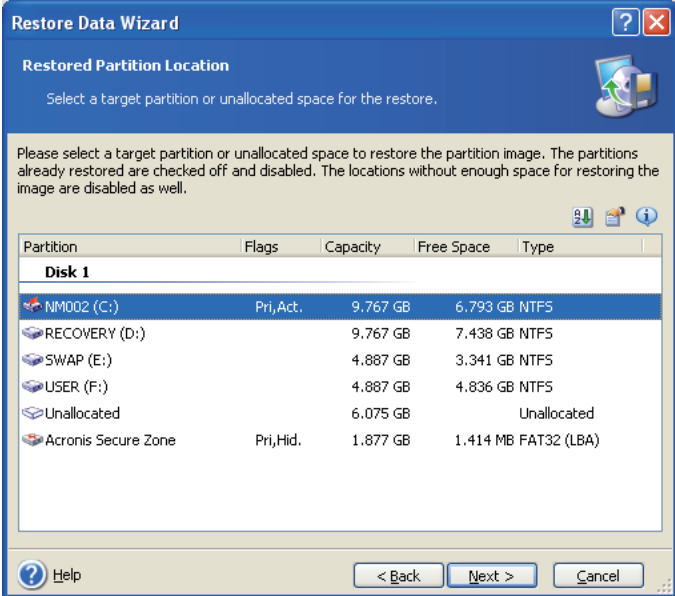

e5052bse1026

Step 11. Select “Active” and click **Next** button.

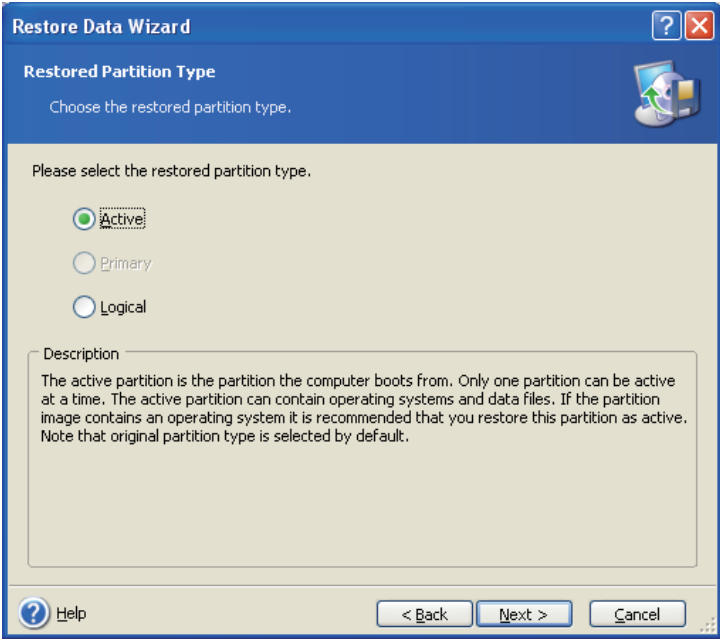

e5071cse1145

System Recovery

System Recovery

Step 12. Click **Next** button.

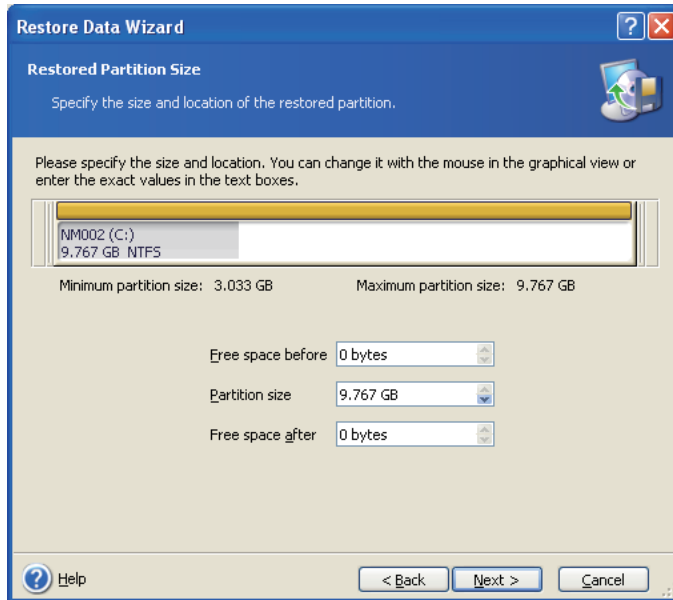

e5052bse1027

Step 13. Select “Yes, I want to assign a logical drive letter to the restored partition” and click **Next** button.

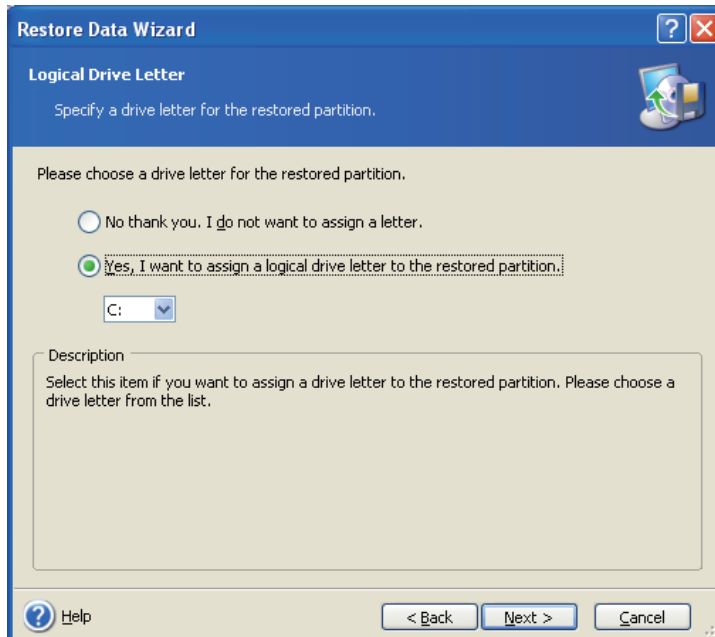

e5071cse1147

Step 14. Select “Yes, I want to restore another partition or hard disk drive,” then click **Next** button.

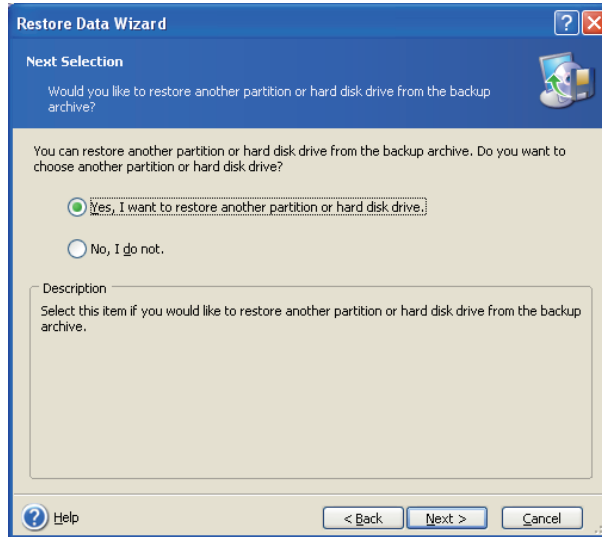

e5052bse1077

Step 15. Select the F drive to restore, then click **Next** button.

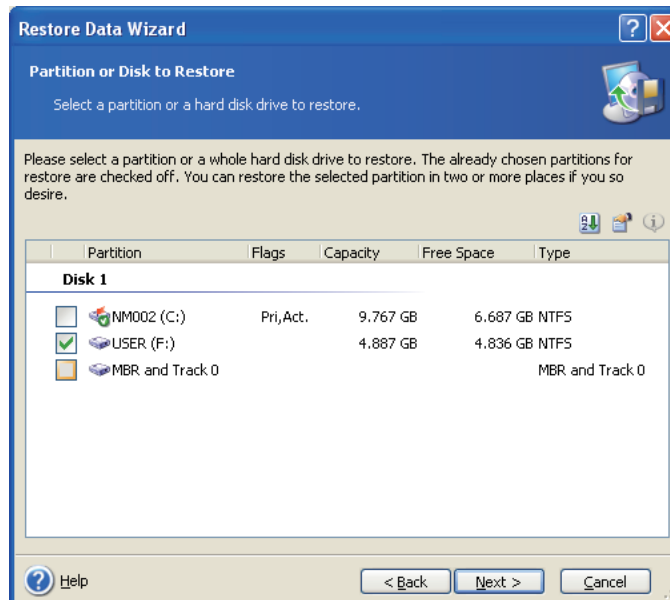

e5052bse1028

System Recovery System Recovery

Step 16. Select the F drive to restore, then click **Next** button.

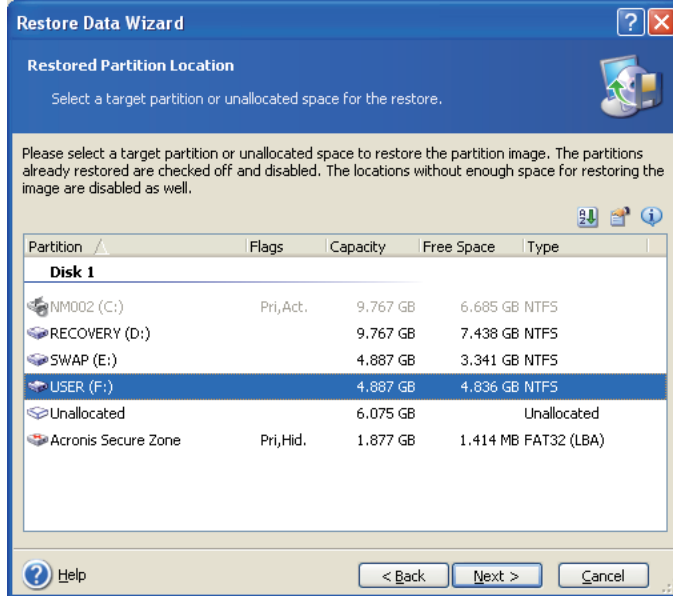

e5052bse1029

Step 17. Select “Logical” and click **Next** button.



e5052bse1078

Step 18. Click **Next** button.

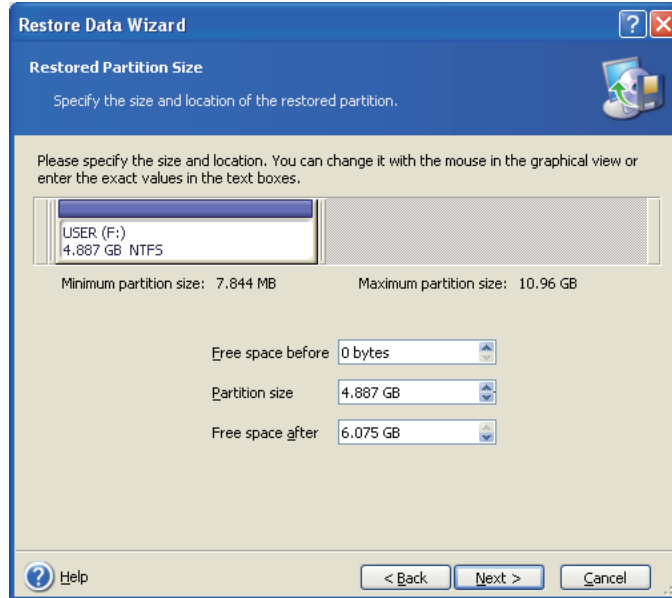

e5052bse1030

Step 19. Select “Yes, I want to assign a logical drive letter to the restored partition,” then click **Next** button.

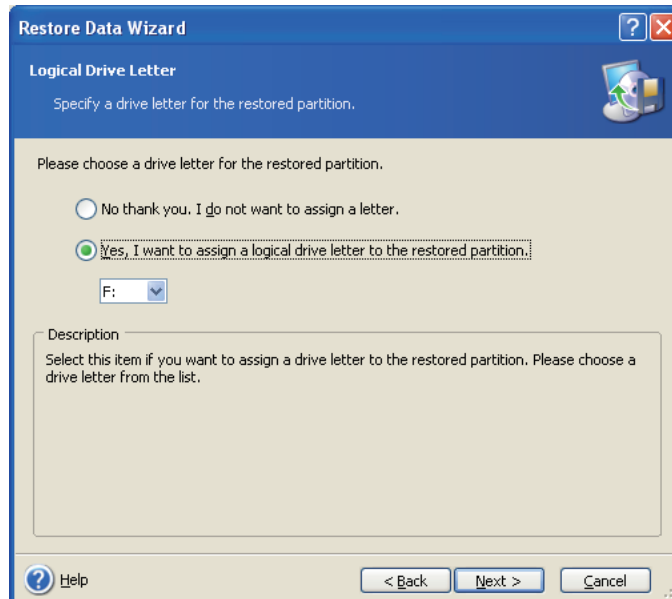

e5052bse1031

System Recovery

System Recovery

Step 20. Select “No, I do not.” and click **Next** button.

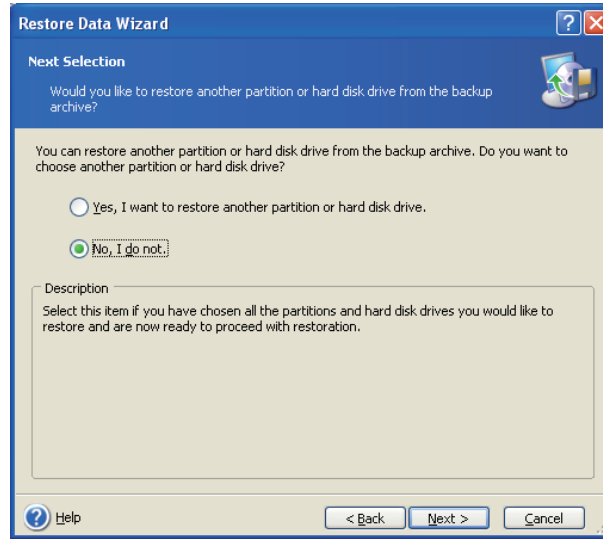

e5052bse1079

Step 21. Select “Set the options manually” and click **Next** button.

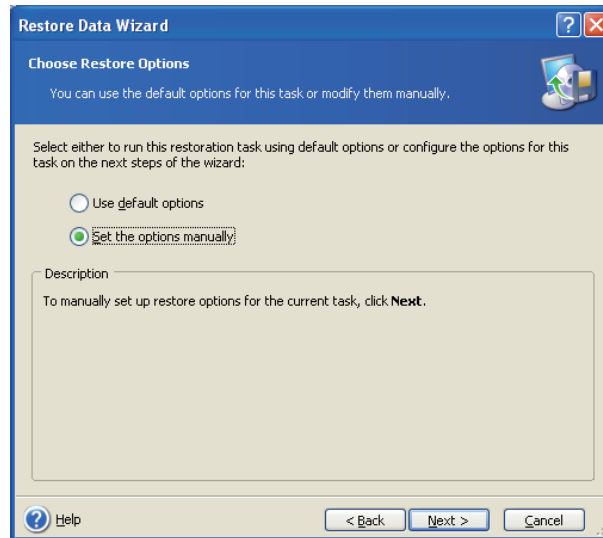

e5052bse1080

Step 22. Select “Restoration Priority” in the left field and “High” in the right field, then click **Next** button.

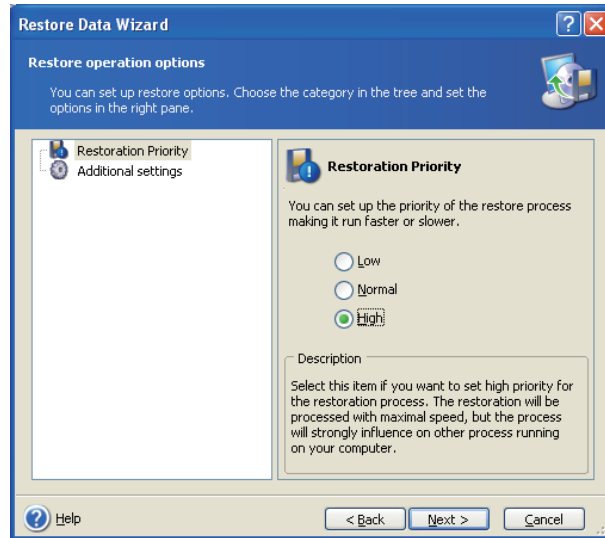

e5052bse1081

Step 23. Click **Proceed** button.

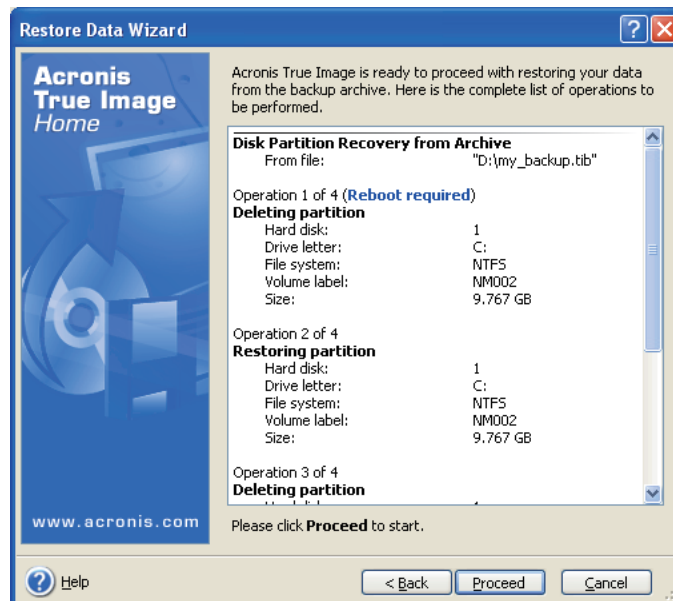

e5052bse1032

System Recovery

System Recovery

Step 24. Click **Reboot** button.

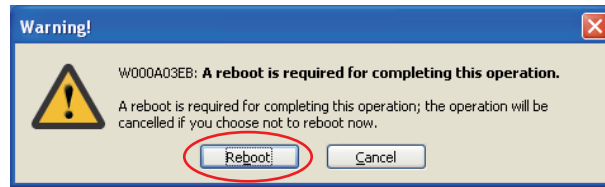

e5052bse1082

CAUTION

Never turn off the power during the recovery of the user backup image because doing so may cause serious damage to the E5052B.

Step 25. After boot up, perform “Initial Registration of E5052B” on page 229 and “Calibration of the Touch Screen” on page 231.

Initial Registration of E5052B

When you start up the E5052B at the first time, you need to perform the initial registration of the Windows XP operating system of the E5052B.

NOTE You cannot use the front panel keys during the initial registration of the E5052B therefore connect the mouse and keyboard before turning on the power.

NOTE If you perform the following procedure incorrectly, a message asking you whether to return to the previous registration screen and perform the registration appears. In this case, follow the instruction to return to the previous registration screen.

Step 1. Turns on the E5052B.

Step 2. The Windows XP Professional Setup wizard appears. Click the **Next >** button (Figure B-4).

Figure B-4 Windows XP Professional Setup wizard



e5071cse1073

System Recovery

Initial Registration of E5052B

Step 3. In the Windows XP Professional Setup dialog box, select the **I accept this agreement** box and click the **Next >** button (Figure B-5).

Figure B-5 Windows XP Professional Setup dialog box (1/2)

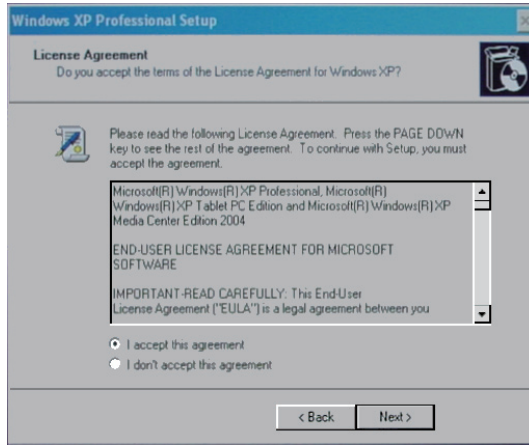

Step 4. In the next dialog box, input **E5052** in the **Name** box. Then, click the **Next>** button (Figure B-6).

Figure B-6 Windows XP Professional Setup dialog box (2/2)

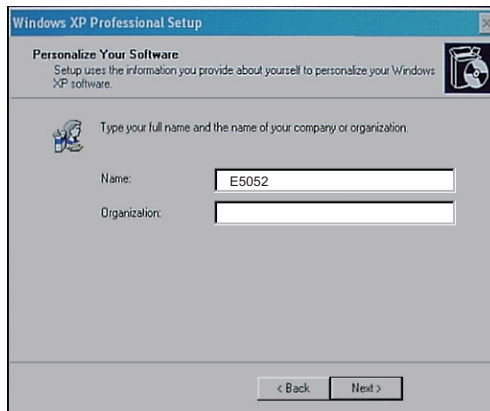

Step 5. After a while, the E5052B restarts automatically. Then, the measurement display appears.

Calibration of the Touch Screen

After E5052B measurement screen appears, you have to calibrate the touch screen. Follow the procedure described below to calibrate the touch screen.

- Step 1. Press **System**.
- Step 2. Press **Service Menu**.
- Step 3. Press **Test Menu**.
- Step 4. Press **Adjust Touch Screen**.

The touch screen calibration screen (Figure B-7) appears.

Figure B-7

Touch Panel Calibration Screen

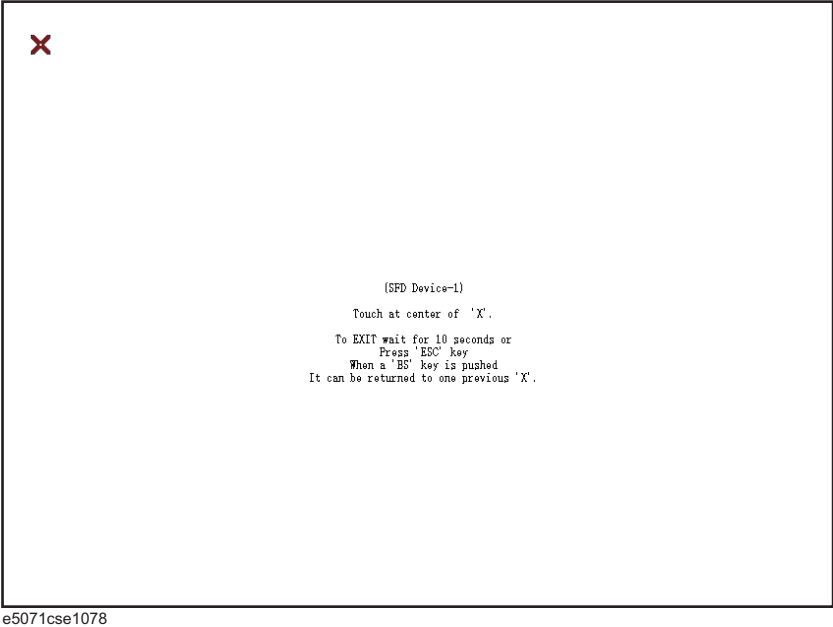

- Step 5. Touch the x mark on the upper left with your finger. The mark x appears also on the upper right, lower left, and lower right. Touch the x marks in that order with your finger. Touching the four locations described above with your finger automatically concludes the touch screen calibration.

NOTE

With no operation on the touch screen calibration screen for a preset time, it automatically closes and the previous measurement screen reappears.

System Recovery
Calibration of the Touch Screen

C **Firmware Update**

This appendix describes how to update the E5052B firmware. When you want to update the E5052B firmware, refer to this appendix.

Firmware Update

Required Equipment

- E5052B (with keyboard and mouse).
- USB memory.

NOTE

The free space of 30 MB or more is necessary for the USB mass storage device.

How to make E5052B Firmware Installation Device

The following is the procedure to make the E5052B Firmware Installation Device.

Step 1. Copy the following files from the Agilent Technologies web site to the USB mass storage device.

- E5052.msi
- Setup.vbs

The latest firmware can be downloaded from the following site.

- <http://www.agilent.com/find/ssa/>

How to update the E5052B Firmware

It is possible to update the E5052B firmware, but not the following software by this procedure.

NOTE

To execute the firmware update, you must first disable a USB Mass Storage Device. For more on how to disable a USB Mass Storage Device, refer to Online Help.

- OS (Operating System)
- VBA (Visual Basic for Application)
- Calibration Constant Data

The following is the procedure to update the E5052B firmware.

Step 1. Prepare the latest E5052B firmware (USB mass storage device).

Step 2. Connect the mouse and keyboard to the E5052B rear panel. Then turn the E5052B on.

Step 3. Connect the USB mass storage device into the front USB port of the E5052B.

Step 4. Update the E5052B firmware.

1. Press **System** key.
2. Press **Service Menu - Administrator Menu - Exit E5052B - OK** on the menu bar.

Step 5. Double-click the “**My Computer**” icon on the Windows desktop.

Step 6. Double-Click the “**Removable Desk (G:)**” icon.

Step 7. Remove the old version of the firmware using the following procedure.

1. Double-Click “**Setup.vbs**” icon. The E5052B Setup Wizard (uninstall) will start automatically as shown in Figure C-1.
2. Click on the **OK** button.

Figure C-1 E5052B Setup Wizard (uninstall)

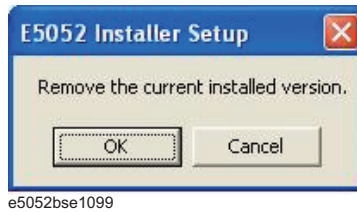

3. Please wait until “Uninstall Wizard” (Figure C-2) disappears.

Figure C-2 E5052B Uninstall Wizard

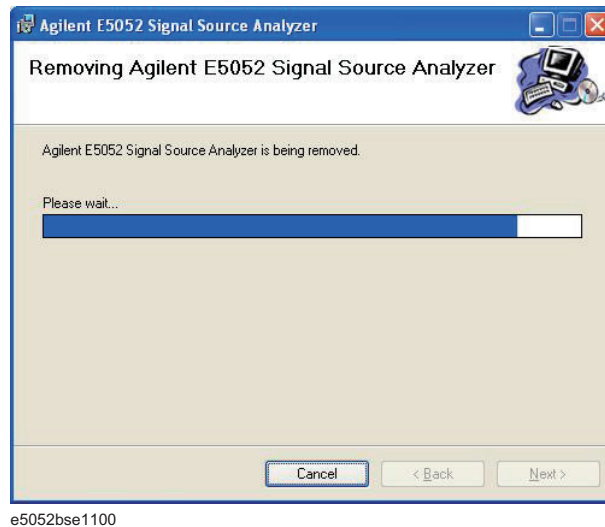

Step 8. Install the new version of the firmware using the following procedure.

1. The E5052B Setup Wizard will start automatically as shown in Figure C-3.

Figure C-3 E5052B Setup Wizard (install)

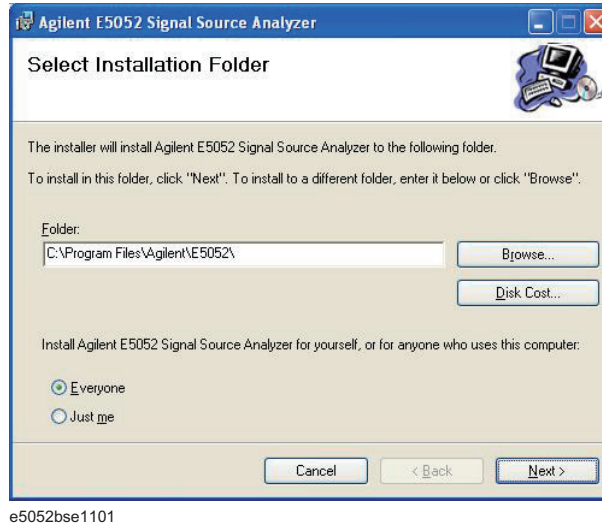

2. Click “**Next**” to continue the firmware installation on the E5052B Setup Wizard as shown in Figure C-3.
3. Please wait until “Install Wizard” (Figure C-4) disappears.

Figure C-4 E5052B Install Wizard

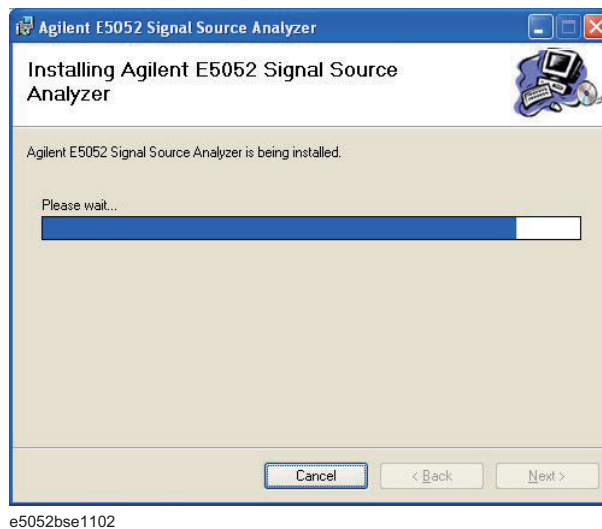

4. Since Figure C-5 is displayed after installation is completed, please click "**Close**" button.

Figure C-5 E5052B Setup Wizard (Completed)

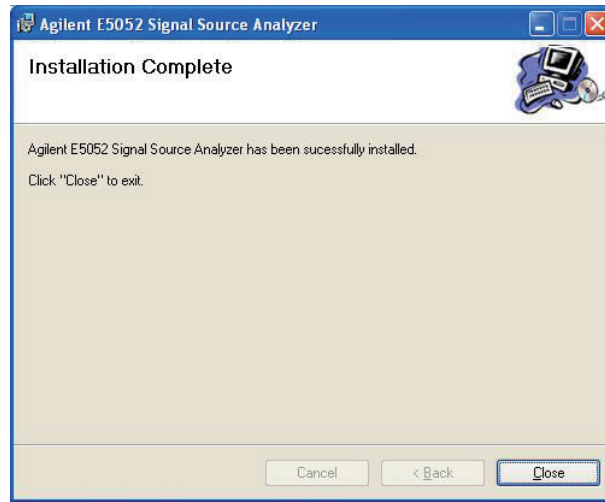

e5052bse1103

- Step 9.** Double-click "**E5052B**" icon on the Windows desktop, and the measurement screen will appear.
- Step 10.** Press **[System]** - **Product Information**. Confirm the firmware revision you have just installed.

Firmware Update
Firmware Update

D **Power Requirement**

Power Supply and Blown Fuses

Before turning on the E5052B power, check the following important items.

Verification of the power supply

Confirm that the power supplied to the E5052B meets the following requirements:

	Requirements
Voltage	90 to 132 VAC or 198 to 264 VAC *1
Frequency	47 to 63 Hz
Maximum power consumption	500 VA

*1. Switched automatically by the E5052B in conformity to the voltage used.

Verification and connection of power cable

The three-wire power cable attached to the E5052B has one wire serving as a ground. Using this power cable allows the E5052B to be grounded, thereby protecting you against electrical shock from the power outlet.

Step 1. Confirm that the power cable is not damaged.





WARNING NEVER use a power cable showing any sign of damage. Faulty cables can cause electrical shock.

Step 2. Use the supplied cable to connect between the power cable receptacle (Figure D-2 on page 244) on the rear panel of the E5052B and a three-wire power outlet, with the grounding prong firmly connected in the ground slot.

WARNING Use the supplied power cable with grounding wire to securely ground the E5052B.

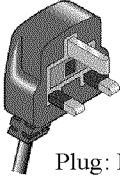
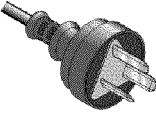
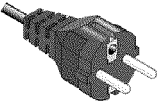
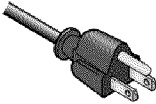
Figure D-1 shows the power cable options.

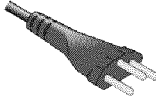
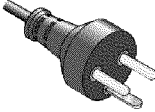
Figure D-1 Power cable options

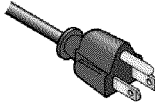
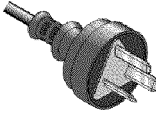
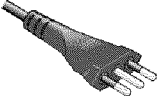
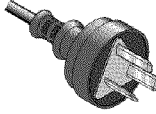
<p>OPTION 900</p>  <p>United Kingdom</p> <p>Plug: BS 1363/A, 250V, 10A Cable: 8120-1351, 8120-8705</p>	<p>OPTION 901</p>  <p>Australia/New Zealand</p> <p>Plug: AS 3112, 250V, 10A Cable: 8120-1369</p>
<p>OPTION 902</p>  <p>Continental Europe</p> <p>Plug: CEE 7 Standard Sheet VII, 250V, 10A Cable: 8120-1689</p>	<p>OPTION 903</p>  <p>U.S./Canada</p> <p>Plug: NEMA 5-15P, 125V, 10A Cable: 8120-1378</p>
<p>OPTION 904</p>  <p>U.S./Canada</p> <p>Plug: NEMA 6-15P, 250V, 6A Cable: 8120-0698</p>	<p>OPTION 906</p>  <p>Switzerland</p> <p>Plug: SEV Type 12, 250V, 10A Cable: 8120-2104</p>
<p>OPTION 912</p>  <p>Denmark</p> <p>Plug: SR 107-2-D, 250V, 10A Cable: 8120-2956</p>	<p>OPTION 917</p>  <p>India/Republic of S. Africa</p> <p>Plug: IEC 83-B1, 250V, 10A Cable: 8120-4211</p>
<p>OPTION 918</p>  <p>Japan</p> <p>Plug: JIS C 8303, 125V, 12A Cable: 8120-4753</p>	<p>OPTION 920</p>  <p>Argentina</p> <p>Plug: Argentine Resolution 63, Annex IV, 250V, 10A Cable: 8120-6870</p>
<p>OPTION 921</p>  <p>Chile</p> <p>Plug: CEI 23-16, 250V, 10A Cable: 8120-6978</p>	<p>OPTION 922</p>  <p>China</p> <p>Plug: GB 1002, 250V, 10A Cable: 8120-8376</p>

NOTE: Each option number includes a 'family' of cords and connectors of various materials and plug body configurations (straight, 90° etc.).

power_e

Power Requirement
Power Supply and Blown Fuses

Blown fuses

If the fuse appears to have blown during operation, this instrument may be subject to failure and must be repaired.

WARNING

Do NOT replace the fuse yourself; doing this may expose you to dangerous electrical shock.





Starting the E5052B

This section explains how to turn on/off the E5052B power, how to cut off the power supply in an emergency, and how to set the internal clock.

Turning the Power ON and OFF



Perform the following steps to turn the power ON or OFF.

Turning the Power ON

- Step 1.** If the standby switch () in the lower-left part of the front panel is in the depressed () position, press it to put it in the popped-up position ().
- Step 2.** Press the standby switch to put it in the depressed position ().
This operation turns ON the power, and the E5052B starts the self-test.
- Step 3.** Confirm that the self-test indicates normal operation.

Normal operation is confirmed by the self-test if no error message appears.

Turning the Power OFF

- Step 1.** Use either of the following methods to turn the power OFF.
- Press the standby switch () in the lower-left part of the front panel (now in the depressed () position) to put it in the popped-up () position.
 - Send the shutdown command from an external controller.

These operations will start the E5052B shutdown process (required software and hardware processes for turning the power off), and the power will turn OFF after a few seconds.

NOTE

Under normal circumstances, always press the standby switch (), or send the shutdown command from an external controller, to execute the E5052B shutdown process. **Never cut off the power supply directly by disconnecting the power cable plug from the rear panel of the unit.**

If the power supply is cut off directly by disconnecting the power cable plug from the instrument or the AC outlet, the shutdown process is not carried out and there is a risk of damage to the E5052B's software or hardware.

Figure D-2

Line switch (Always ON) and power cable receptacle

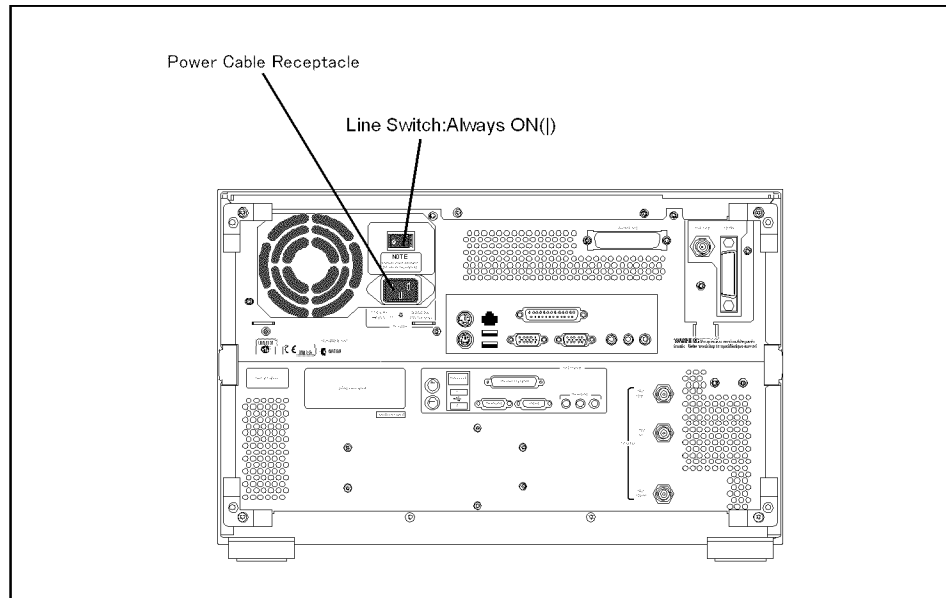

e5052aue013

Disconnection from supply source

The power supply of the E5052B is cut off by disconnecting the plug of the power cable (on either AC outlet side or E5052B side). When it is necessary to disconnect the power supply in order to avoid shock hazards, etc., pull out the power cable plug from either the AC outlet side or the E5052B side.

E Messages

The E5052B can display error messages as well as messages that indicate the internal operating status of the equipment. This appendix explains what these messages mean. They are listed in alphabetical order.

Messages showing the status of the E5052B are displayed in the lower-left area of the E5052B LCD screen. These messages include error messages that occur during the

Messages

execution of GPIB commands and others that indicate the internal status of the equipment.

Error messages are indicated following the character string “[Err]” and can be read out by a GPIB command. Other kinds of messages are indicated without the “[Err]” character string and cannot be read out by a GPIB command. This section explains the meaning of each message and how to resolve the problem it indicates.

Error Messages

An error message is displayed against a red background in the instrument message/warning area in the lower-left part of the screen. Touching **Entry Off** key at the front panel or executing the **:DISPlay:MESSage:CLEar** command clears the error message. Moreover, about a specific error message, when a sweep is started again, the display of an error message may disappear. Errors caused by operation of a front panel key simply appear on the display; with a few exceptions, these are not stored in the error queue.

The log of an error message, a maximum of 100 pieces are recorded, and it can go back and check from the newest error. The following procedures perform the procedure of elimination of an error check and an error log. This operation can be performed only from a front panel. It cannot be operated by the "SCPI" command.

[System] - Service Menu - Error Log - View Error Log

[System] - Service Menu - Error Log - Clear Error Log

An error with a positive error number is one uniquely defined for this instrument. On the other hand, an error with a negative error number is basically one defined for common GPIB devices in IEEE488.2

A

120

AFC Failed

This error message appears when the Automatic frequency control function could not follow the fluctuation in the measurement condition or automatic frequency control function was set on, however, the power or control voltage is not being applied to the DUT. For the corrective actions, refer to the error message "AFC out of loop" and the warning message "DC output on required in AFC".

330

AFC out of loop

The Automatic frequency control function could not follow the fluctuation in the measurement condition, and did not converge on the target frequency. Possible problems and corrective action are shown below.

- Press **[DC Control]** - **Auto Freq Control - Sensitivity** to specify a proper tuning sensitivity.
- Press **[DC Control]** - **Auto Freq Control - Max Iteration** to specify a value larger than the current setting.
- Press **[DC Control]** - **Auto Freq Control - Max Ctrl Voltage Limit** to specify a maximum value larger than the current setting. Be careful not to set a value that exceeds the DUT's maximum acceptable value.
- Press **[DC Control]** - **DC control Delay** to specify a value larger than the current setting.

51

A21 flash ROM write error

This error occurs when writing the system calibration data to ROM on the A21 board fails. Contact Agilent Technologies' Customer Contact given at the end of this guide or the company from which you bought the device.

311

A4/A5 local unlocked

Messages
Data out of range

This error occurs when the internal local signal of the instrument cannot be unlocked. There is the possibility of a device failure. Contact an Agilent Technologies sales office or the company from which you bought the device.

D

-222

Data out of range

A data element (not violating the standard) outside the range defined by this instrument has been received. This error occurs, for example, when an integer-based command for which the parameter can be rounded exceeds the range of -65536 to +65536 or when a real-number-based command for which the parameter can be rounded exceeds the range of -9.9e37 to +9.9e37.

280

DC control overload

The current through the DC CONTROL connector is too large.

270

DC power overload

The current through the DC POWER connector is too large.

373

Downconverter Fan Stop

This error occurs when the fan of the downconverter stops. Contact Agilent Technologies' Customer Contact given at the end of this guide or the company from which you bought the device.

354

Downconverter IF not found

This error occurs when the down-converted signal does not fall into the expected IF range. The deviation between the set nominal frequency and the actual input signal's frequency may be too large. Execute the carrier search function, and set a correct nominal frequency.

352

Downconverter Oven Cold

This error may occur due to the unlocked PLL because the oven is not heated sufficiently for some time after the downconverter is turned on. Heat the oven for some time with the power on.

374

Downconverter P5V power fail

This error occurs when the 5-V power of the downconverter fails. A device failure is suspected. Contact Agilent Technologies' Customer Contact given at the end of this guide or the company from which you bought the device.

353

Downconverter Ref Input Level Low

This error occurs when the level of the 10-MHz reference signal to the downconverter is low.

372

Downconverter Ref PLL unlocked

This error occurs when the PLL circuit of the downconverter is unlocked during measurement. This error may occur when the carrier frequency of the measurement sample is unstable.

It may occur also due to the same reason as "Downconverter Oven Cold."

375

Downconverter test failed

This error occurs when the self-test of the downconverter fails. A device failure is suspected. Contact Agilent Technologies' Customer Contact given at the end of this guide

or the company from which you bought the device.

371

Downconverter Unlock local

This error occurs when the local of the downconverter cannot be locked. A device failure is suspected. Contact Agilent Technologies' Customer Contact given at the end of this guide or the company from which you bought the device.

E

-200

Execution error

An error associated with execution has been generated for which this instrument cannot specify the error message. This code shows the occurrence of an error associated with execution, as defined in 11.5.1.1.5, IEEE488.2.

F

72

Failed to copy file

This error occurs when copying a file (MMEM:COPY command) fails.

74

Failed to create directory

This error occurs when creating a directory (MMEM:MDIR command) fails.

73

Failed to delete file

This error occurs when deleting a file (MMEM:DEL command) fails.

91

Failed to execute user defined key

In the user menu function, this error occurs when a disabled softkey is executed.

61

Failed to hide trace

In the user window, this error occurs when the show trace "OFF" command is executed to turn off the remaining trace on the window. At least one trace should be visible at all times.

60

Failed to hide window

This error occurs when the show window "OFF" command is executed to turn off the remaining window on the screen. At least one window should be visible at all times.

70

Failed to read file

This error occurs when a VBA project file (MMEM:LOAD:PROG command) or other type of file cannot be read normally.

90

Failed to stop program

This error occurs when stopping a program fails.

71

Failed to write file

This error occurs when the display image (MMEM:STOR:IMAG command) for the LCD screen, a VBA project file (MMEM:STOR:PROG command) or other type of file cannot be written normally.

-257

File name error

A file name error. This message appears when an error exists in the file name and thus a command is not executed correctly. This error occurs, for example, when you try to copy to an improper file name.

Messages
File name not found

- 256 **File name not found**
- The file name specified is not found and thus the command is not executed correctly. This error occurs, for example, when you try to read a file that does not exist in a disk or a disk is not correctly inserted into the drive.
- 80 **File transfer failed**
- This error occurs when writing data into or reading data from a file (MMEM:DATA command) fails.
- I**
- 213 **IF A/D overflow**
- This message appears when the internal IF level is too high and it exceeds the internal A/D converter input range. In the phase noise measurement, check that the DUT's carrier signal is within the selected frequency band. Also, the message may appear if a DUT that has a large noise level and an unstable output level is measured. When measuring phase noise in such a case, decrease the IF Gain value or increase the sweep start value if possible. In the spectrum monitor measurement, decrease the DUT's carrier level, or set the reference level or input attenuator value larger than the current setting. In the transient measurement, decrease the DUT's carrier level, or set the max input level or input attenuator value larger than the current setting.
- 260 **IF Level Overload**
- The IF level is too high. Set the input attenuator value larger than the current setting.
- 312 **IF not found**
- The IF signal cannot be found. In the phase noise measurement, this error occurs when no signal is inputted to the RF IN, or the input level to the RF IN is too low. Also, the message may appear if a DUT that has an unstable output level is measured. Aside from the above reasons, there is the possibility of a device failure. Contact an Agilent Technologies sales office or the company from which you bought the device.
- 224 **Illegal parameter value**
- The parameter value is improperly set.
- 282 **Illegal program name**
- This error occurs when a nonexistent VBA program name is specified by the PROG:SEL:NAME command.
- 213 **Init ignored**
- Because another measurement is in progress, the request for initiating a measurement ("INIT" command) is ignored.
- 250 **Insufficient IF Level**
- The IF level is too low. Set the input attenuator value smaller than the current setting.
- 230 **Insufficient RF Level**
- The input level to the RF IN connector is too low.
- 50 **Internal test failed**
- Internal test failed.

L

101

License installation failed

This error occurs when an invalid license code is input during installation of the E5001 SSA-J license.

77

Load VBA program failed

This error occurs when loading a VBA program file fails.

M

20

Marker search failed

This error occurs when marker search fails.

-109

Missing parameter

The number of parameters is less than that required for the command, or the parameter has not been entered.

N

351

No downconverter unit connected

This error occurs when the downconverter is not turned on or when the USB (USBTMC) cable is not connected even though the downconverter is enabled. Disable the downconverter, turn on the downconverter, or connect the USB (USBTMC) cable.

111

No signal found

This error message appears when a carrier is outside the selected frequency band or the attenuator is improperly set during the execution of **Carrier to** function. Set the attenuator to 0 in case you measure a DUT whose output is less than -15dBm.

O

100

Option not installed

The command received has been ignored because of the mismatch between the contents of an option for this instrument and the command.

This error is not generated by front key operations.

290

Oven Cold

This error occurs when PLL cannot be locked because the oven is not warm enough after start-up the E5052B.

P

-220

Parameter error

When a parameter-related error other than Errors -221 through -229 occurs, that error is displayed.

-108

Parameter not allowed

The number of parameters exceeds that required for the command.

Messages
Power on test failed

See the command reference to confirm the required number of parameters.

200 **Power on test failed**

This error occurs when the power-on test fails, indicating a failure of the instrument. Contact an Agilent Technologies sales office or the company from which you bought the instrument.

40 **Printer error**

This error occurs when the previous printing is still in progress or the printer fails (offline, short of paper, etc.) at the time of outputting the display image on the LCD screen to the printer (HCOP:IMM command).

41 **Print failed**

This error occurs when printing fails for reasons other than Error 40, Printer error.

-284 **Program currently running**

This error occurs when the PROG:SEL:STAT RUN command is executed when the VBA program is in the Run state.

-286 **Program runtime error**

An error occurring when VBA is executed.

R

75 **Recall failed**

This error occurs when reading an instrument status file (State01.sta, etc.) (MMEM:LOAD:STAT command) fails.

220 **RF freq out of range**

This error occurs when the DUT's output frequency is not within the measurement range.

240 **RF level overload**

This error occurs when the input to the RF IN port exceeds the maximum input level in the measurement. The measurement value obtained in such a case is not correct. In the worst case, a failure (damage to the receiver) may occur.

S

76 **Save failed**

This error occurs when writing an instrument status file (State01.sta, etc.) (MMEM:STOR:STAT command) fails.

78 **Save VBA program failed**

This error occurs when saving a VBA program file fails.

210 **System PLL unlocked**

This error occurs when the PLL circuit of the instrument becomes unlocked while the measurement is in progress. This message may appear if the DUT's carrier signal is unstable. If this message is displayed in the phase noise measurement, the following problems and corrective actions are shown below.

- The DUT's noise level is too large, or a large level spurious component exists in the

	measurement range.
	Verify the spectrum of the DUT's output signal.
	Decrease the IF Gain value, or increase the sweep start value when possible.
	<ul style="list-style-type: none">• The DUT's output signal is being modulated in frequency. Stop the frequency modulation.• A large harmonics component is included in the DUT's output signal. Insert a low-pass filter between the DUT's output terminal and the E5052B RF IN connector to eliminate the harmonics component.
211	System PLL frequency range over This error occurs when the internal PLL circuit becomes unlocked while the measurement is in progress. This error may occur when the frequency of the input signal is out of range.
212	System PLL Input overflow This error occurs when the internal PLL circuit becomes unlocked while the measurement is in progress. This error may occur when the level of the input signal is too large.
214	System FLL unlocked This error occurs when FLL version of "210 system PLL unlocked". When the capture range in PN measurement in Normal, it's 210 and When Wide, 214.
215	System FLL frequency range over This error occurs when FLL version of "211 system PLL frequency range over". When the capture range in PN measurement in Normal, it's 211 and When Wide, 215.
-310	System error One of the errors designated as "system errors" in this instrument has occurred.
	T
110	Target freq out of range This error indicates the 2nd, 3rd, or nth order harmonics is not within the E5052B measurement range. At this time, the previous measurement conditions still remain (any of sweep parameters are not changed).
-223	Too much data The block-, expression-, or character-string-type program data that have been received conform with the standard but exceed the amount that can be processed under the conditions of the memory or conditions specific to memory-related devices. In this instrument, this error occurs when the number of characters exceeds 254 in a character-string parameter.
-211	Trigger ignored This instrument receives and detects a trigger command ("TRIG") or an external trigger signal, but it is ignored due to the timing conditions (the instrument is not in the wait-for-trigger state, for example). Change the setup so that a trigger command or an external trigger signal can be sent after the instrument has entered the wait-for-trigger state.
320	Thermometer out of range

Messages
Undefined header

The internal thermometer reading is out of the proper range. Adjustment or repair is necessary.

U

-113

Undefined header

A command not defined in this instrument, although not illegal in the syntactic structure, has been received. See the command reference and use correct commands.

REGIONAL SALES AND SUPPORT OFFICES

For more information about Agilent Technologies test and measurement products, applications, services, and for a current sales office listing, visit our web site: <http://www.agilent.com/find/tmdir>. You can also contact one of the following centers and ask for a test and measurement sales representative. 21/01/2004

United States:

Test and Measurement Call Center
(tel) 1 800 452-4844
(fax) 1 888 900-8921

Australia/New Zealand:

(tel) (61 3) 9210-5555 (Australia)
(fax) (61 3) 9210-5899
(tel) (64 4) 939-0636 (New Zealand)
(fax) (64 4) 972-5364

Canada:

Test and Measurement Call Center
(tel) 1 877 894-4414
(fax) 1 888 900-8921

Asia Pacific:

(tel) (65) 6375-8100
(fax) (65) 6836-0252
Email: tm_asia@agilent.com

China:

(tel) 800 810-0189
(fax) 800 820-2816

Europe:

(tel) (31 20) 547-2323
(fax) (31 20) 547-2390

Japan:

Call Center
(tel) 0120 421-345
(tel) (81) 426 56-7832
(fax) (81) 426 56-7840

Korea:

(tel) (82 2) 2004-5004
(fax) (82 2) 2004-5115

Latin America:

(tel) (305) 269-7500
(fax) (305) 269-7599

Taiwan:

(tel) 0800 047 866
(fax) 0800 286 331